

Atlas of Structures, Mechanisms, and Robots

Dr. Bob Williams, williar4@ohio.edu

Mechanical Engineering, Ohio University

© 2012 Dr. Bob Productions

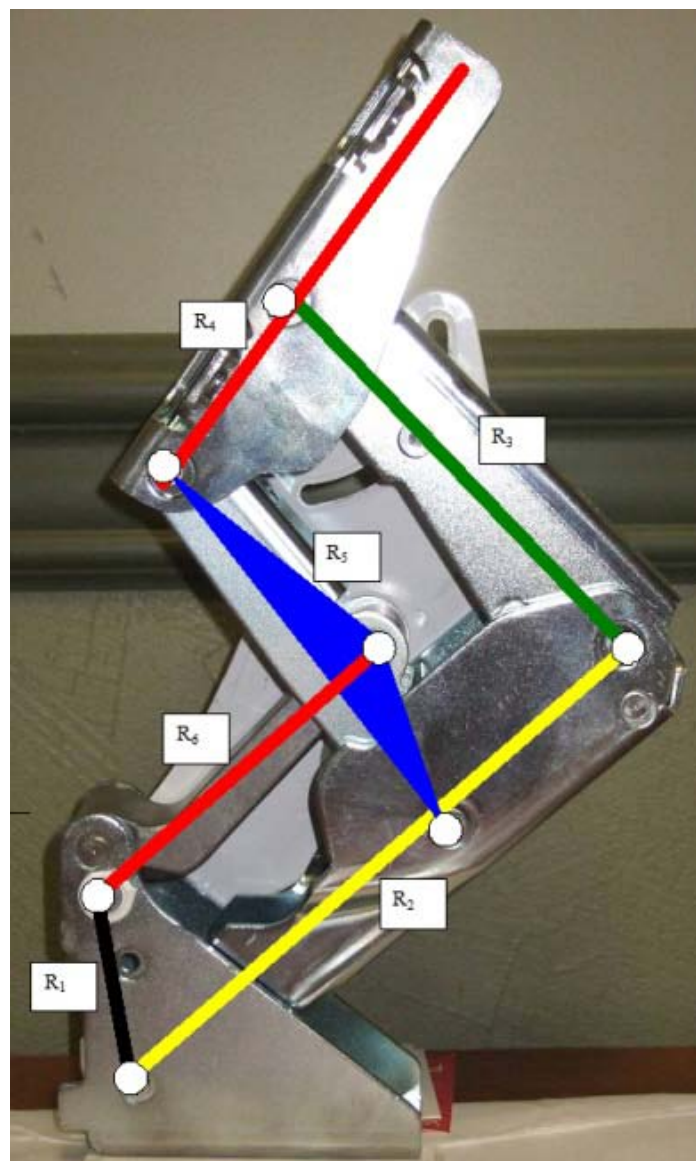

Hettich Hinge Watt I 6-bar Mechanism

Table of Contents

ZERO-DOF (OR LESS) STRUCTURES.....	3
ONE-DOF MECHANISMS.....	3
MULTI-DOF ROBOTS.....	16
REAL-WORLD MECHANISMS / KINEMATIC DIAGRAMS.....	18
MATLAB SIMULATION/ANIMATION GALLERY.....	19

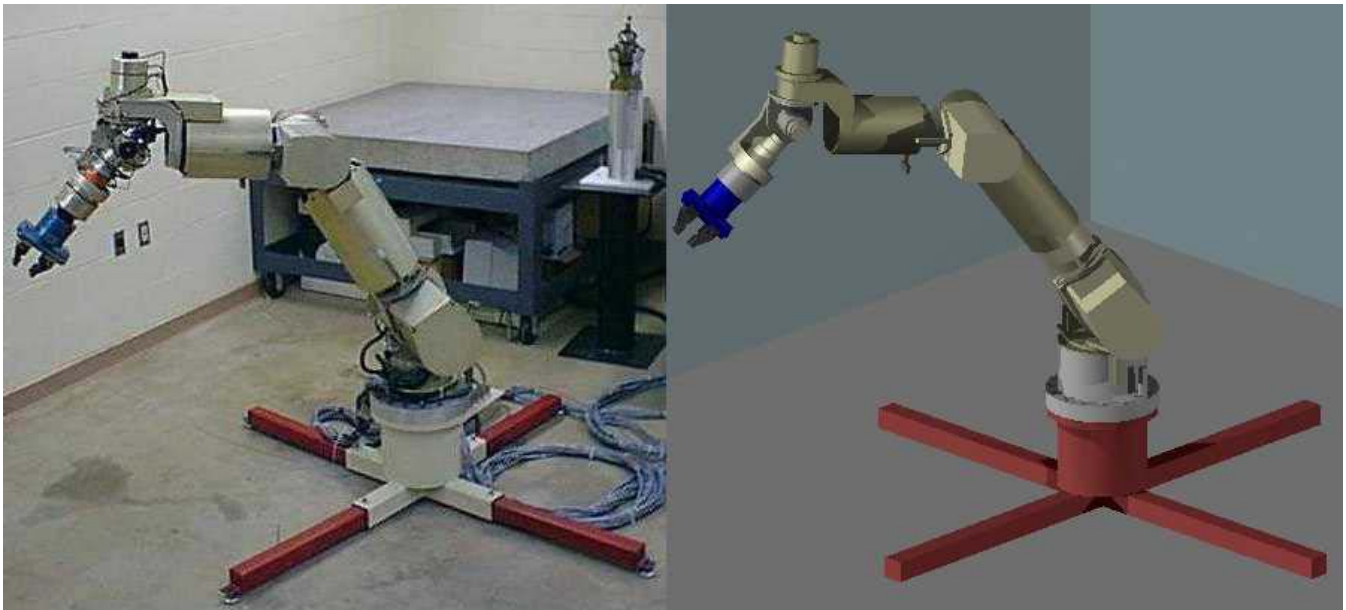

NASA 8-dof ARMII Robot

Zero-dof (or less) Structures

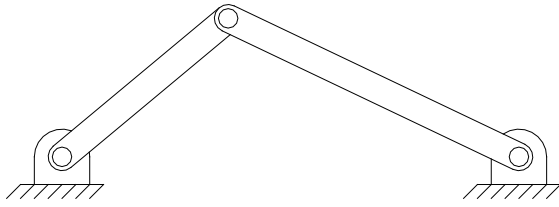

Statically Determinate Structure

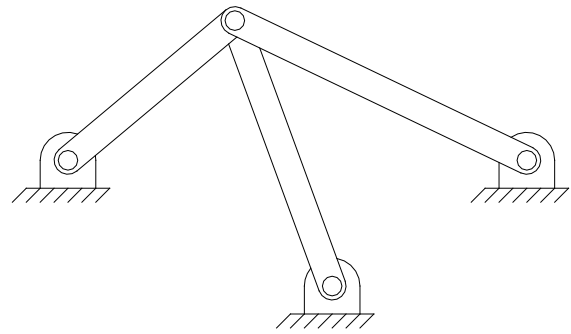

Statically Indeterminate Structure

One-dof Mechanisms

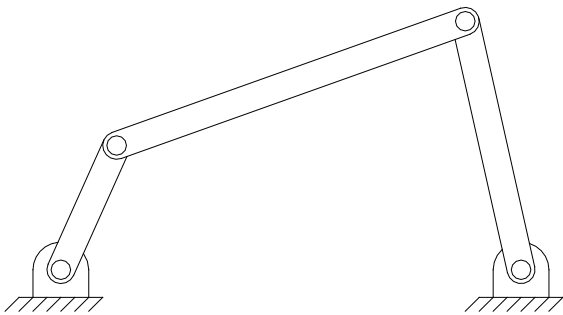

4-Bar Mechanism

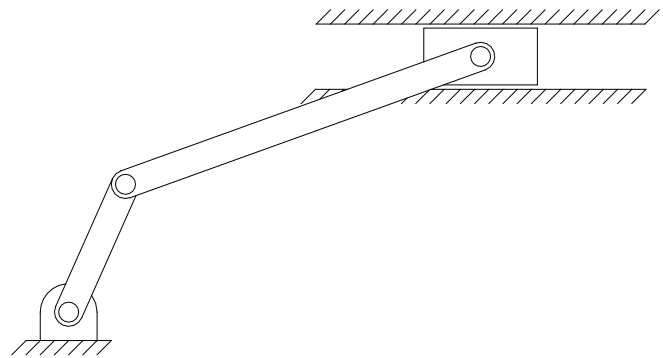

Offset Slider-Crank Mechanism

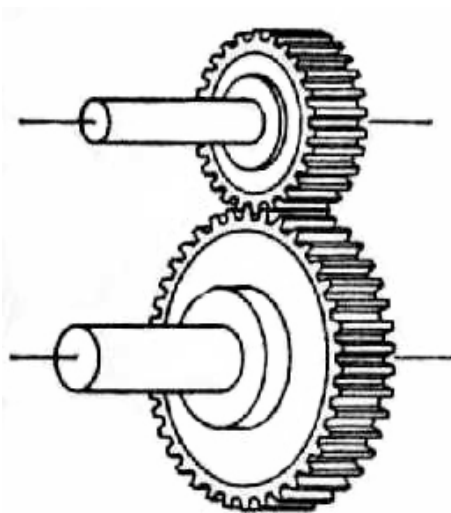

Spur Gear Mechanism

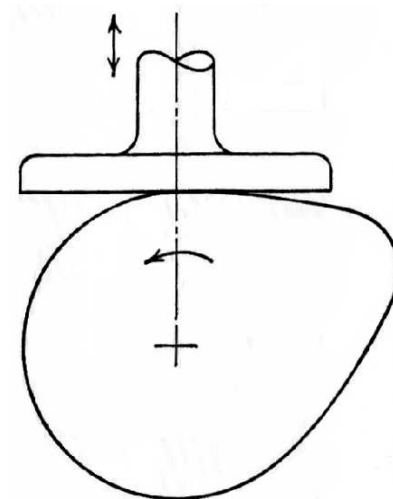

Cam-and-Follower Mechanism

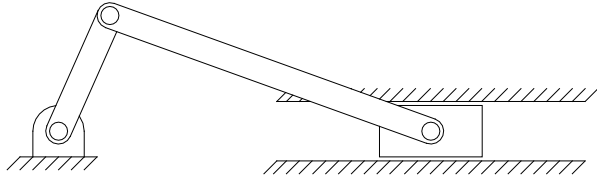

Slider-Crank Mechanism Inversion 1

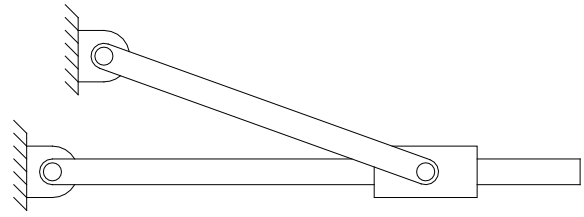

Slider-Crank Mechanism Inversion 2

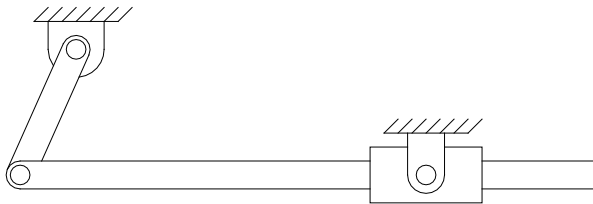

Slider-Crank Mechanism Inversion 3

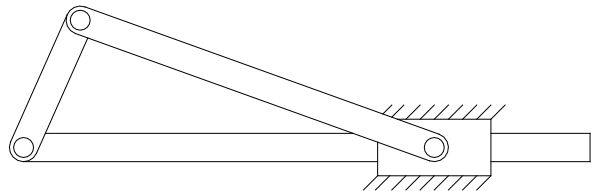

Slider-Crank Mechanism Inversion 4

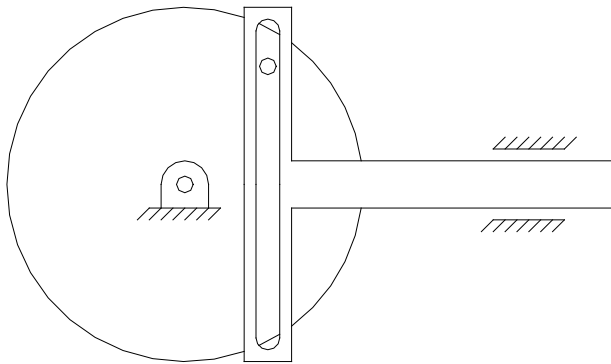

Scotch-Yoke Mechanism

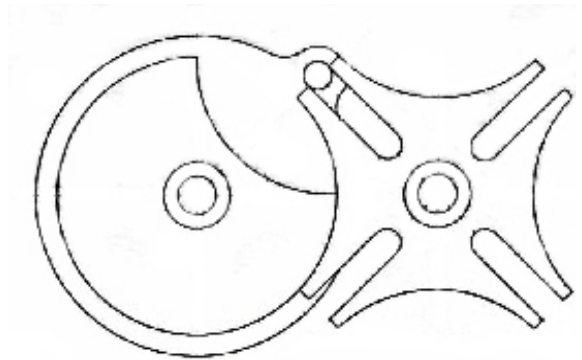

Geneva Wheel Mechanism

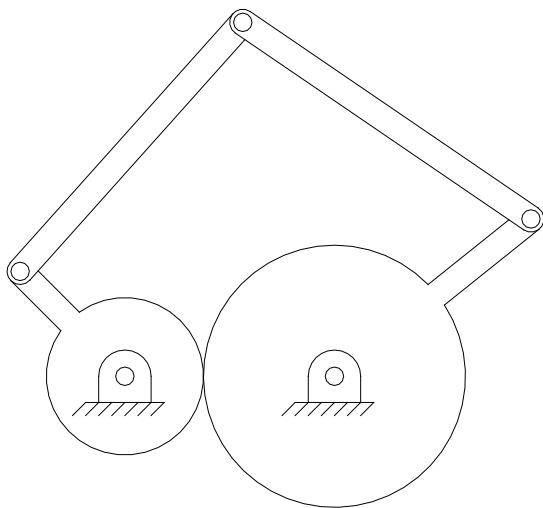

Geared 5-Bar Mechanism

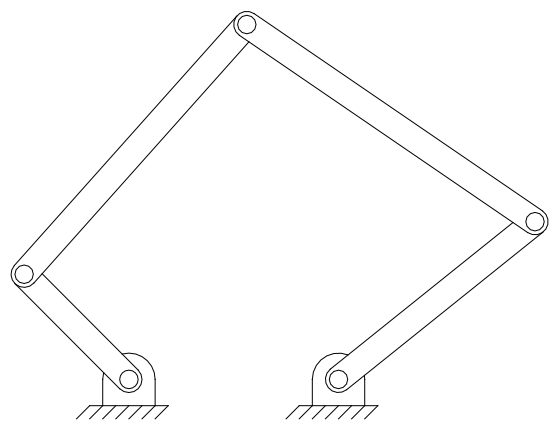

2-dof 5-Bar Parallel Robot

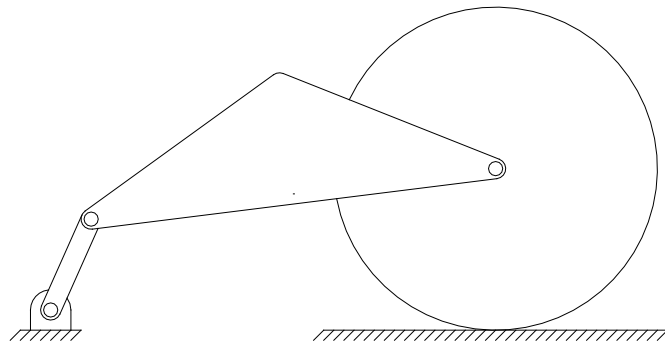

4-Bar Rolling Mechanism

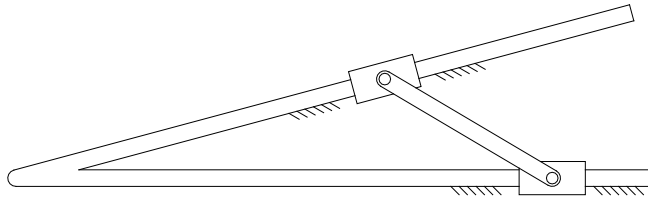

Dual-Slider Mechanism

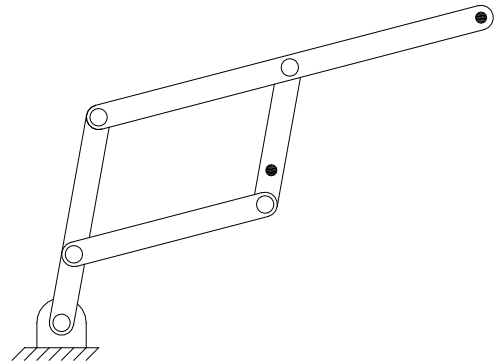

Pantograph Robot

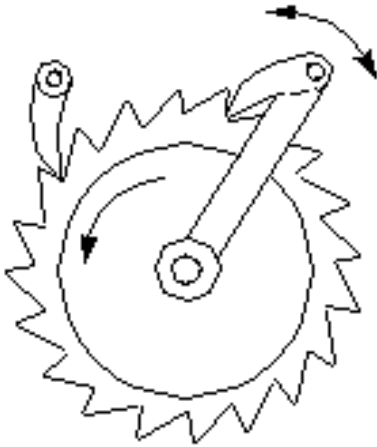

Ratchet Mechanism

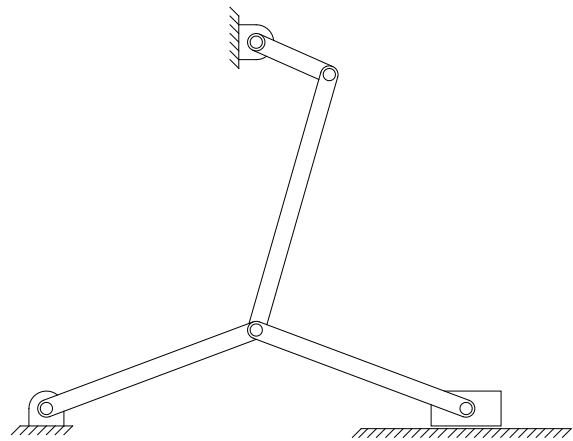

Toggle Mechanism

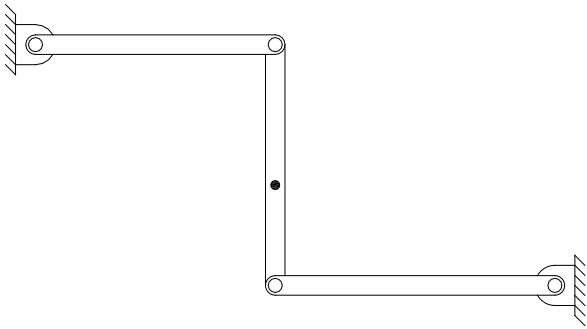

**Watt Straight-Line Mechanism
(approximate)**

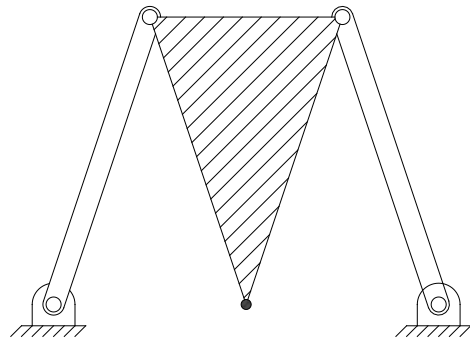

**Roberts Straight-Line Mechanism
(approximate)**

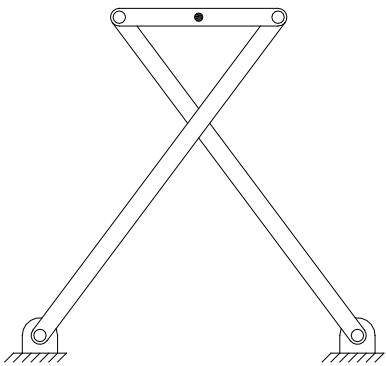

**Chebyshev Straight-Line Mechanism
(approximate)**

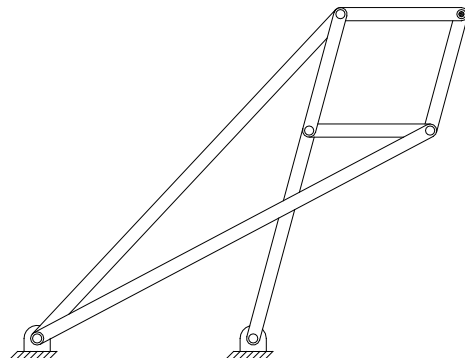

**Peaucellier Straight-Line Mechanism
(exact)**

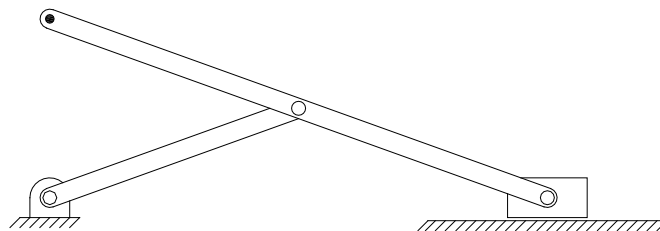

**Scott-Russell Straight-Line Mechanism
(exact)**

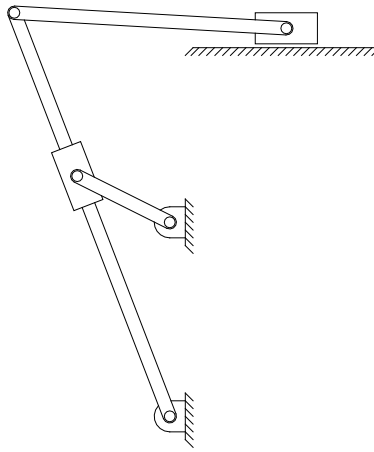

Crank-Shaper Quick-Return Mechanism

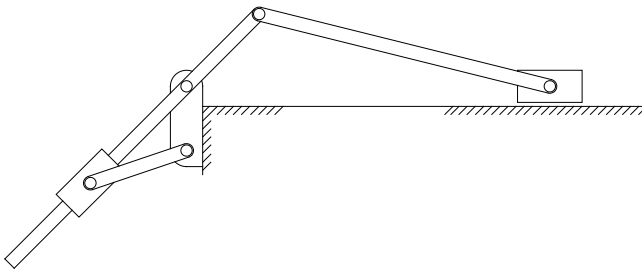

Whitworth Quick-Return Mechanism

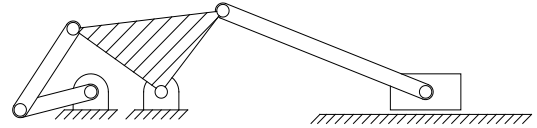

Drag-Link Quick-Return Mechanism

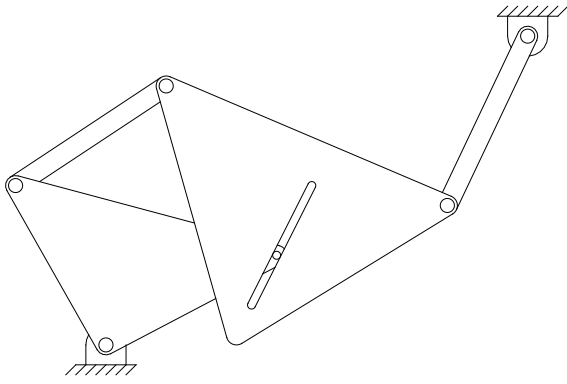

5-bar Slotted Mechanism

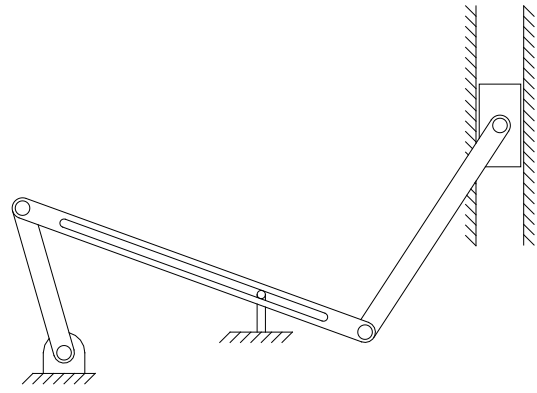

5-bar Slotted Slider Mechanism

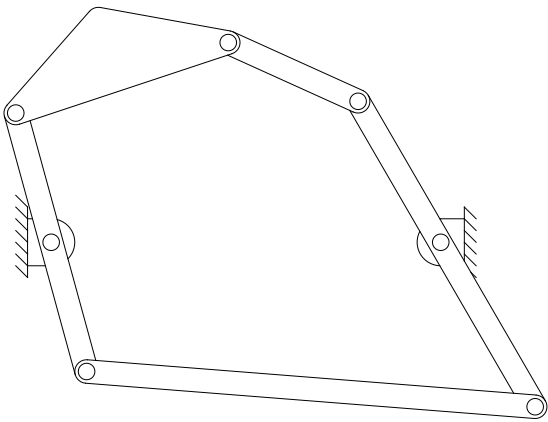

6-bar Mechanism

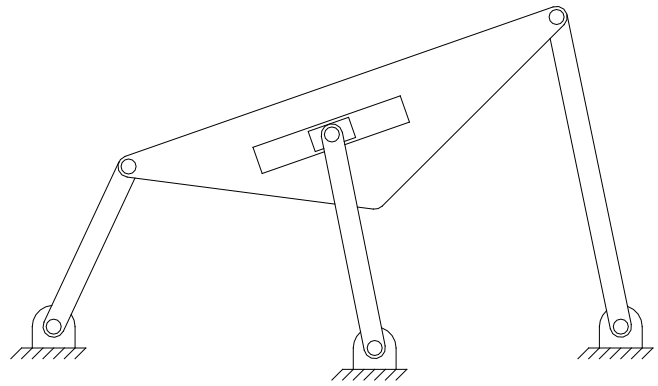

6-bar Single-Slider Mechanism

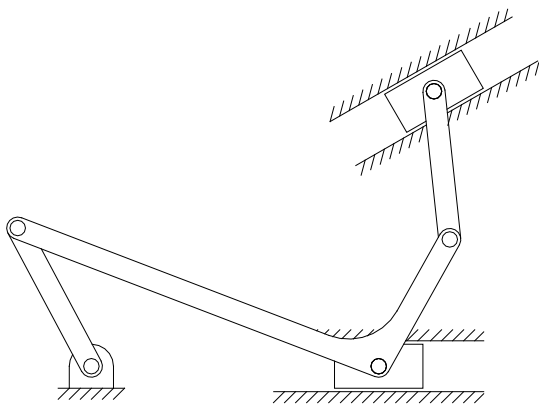

6-bar Crank Dual-Slider Mechanism

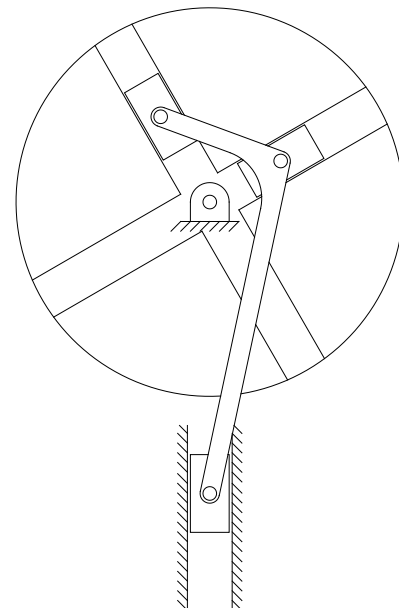

6-bar Crank Triple-Slider Mechanism

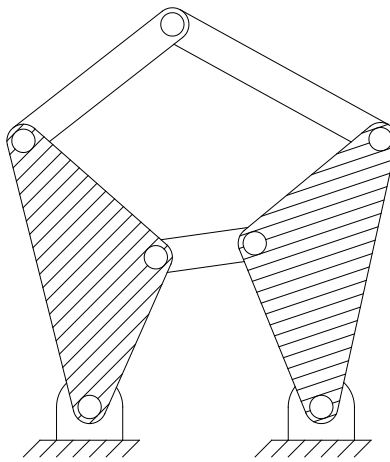

Stephenson I 6-Bar Mechanism

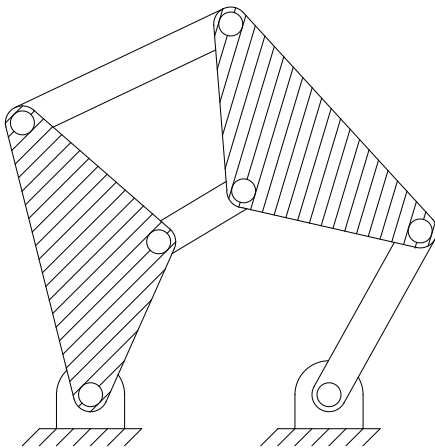

Stephenson II 6-Bar Mechanism

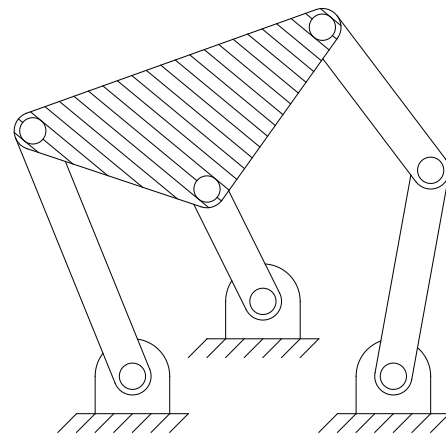

Stephenson III 6-Bar Mechanism

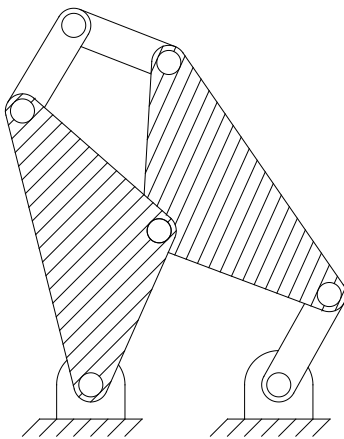

Watt I 6-Bar Mechanism

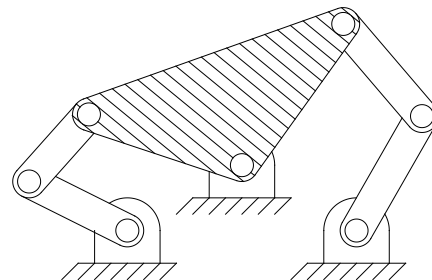

Watt II 6-Bar Mechanism

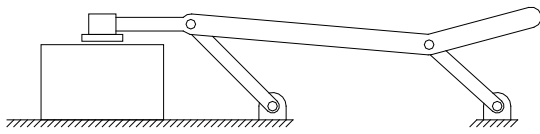

4-Bar Clamp Mechanism

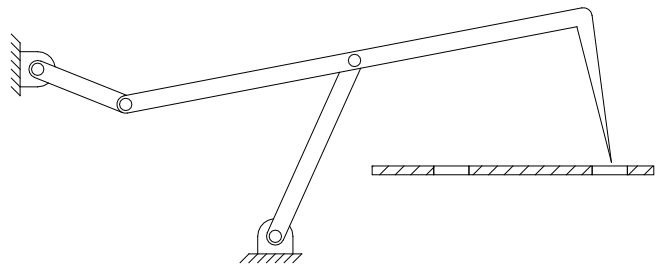

4-Bar Film Advance Mechanism

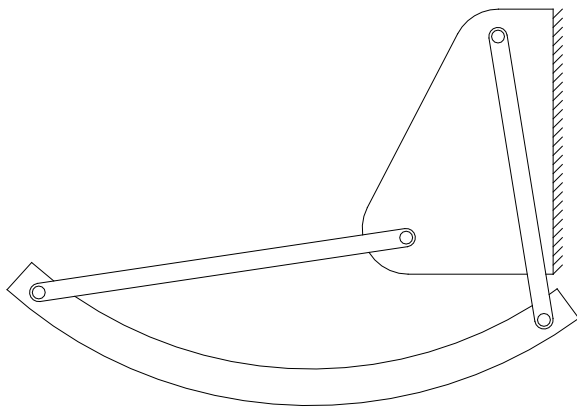

4-Bar Aircraft Carry-on Bin Mechanism

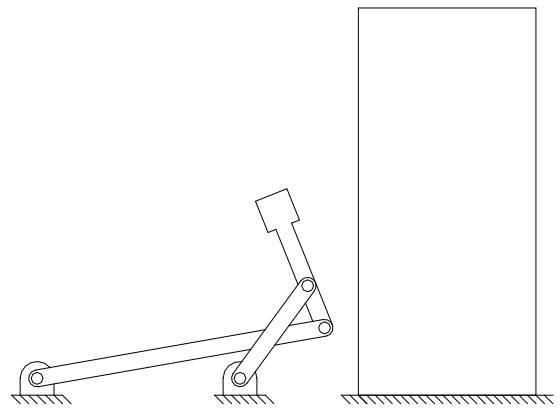

4-Bar Bass Drum Pedal Mechanism

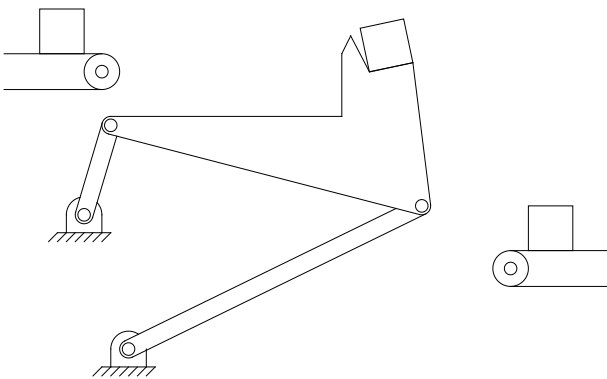

4-Bar Conveyor Transfer Mechanism

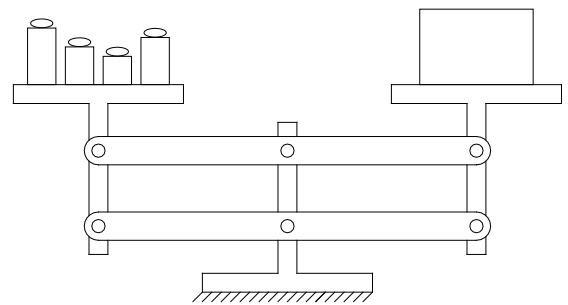

Dual 4-bar Balance Scale Mechanism

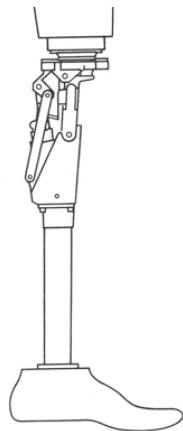

4-Bar Knee Prosthesis Mechanism

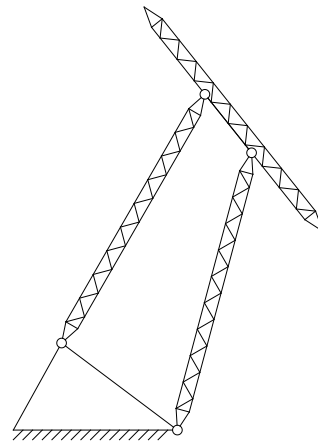

4-Bar Crane Mechanism

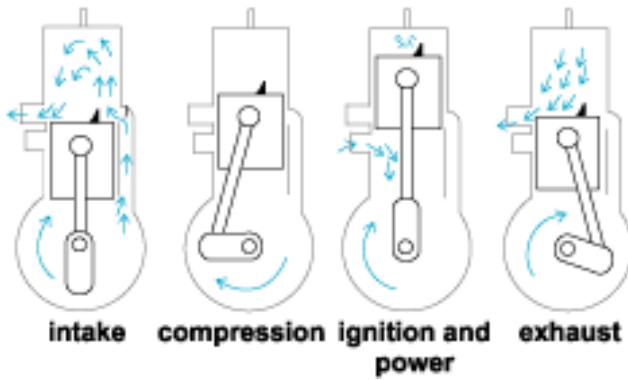

2-Stroke Internal Combustion Engine Mechanism S-C Inversion 1

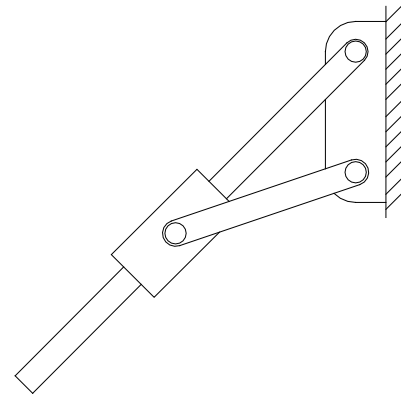

Whitworth Mechanism S-C Inversion 2

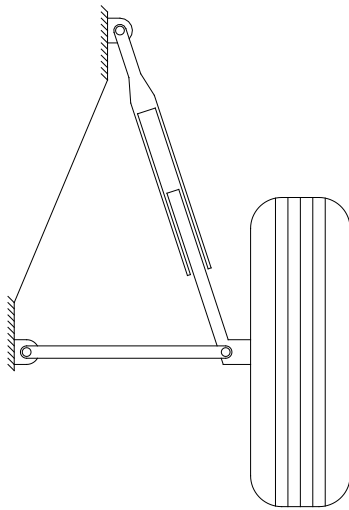

MacPherson Strut Mechanism S-C Inversion 3

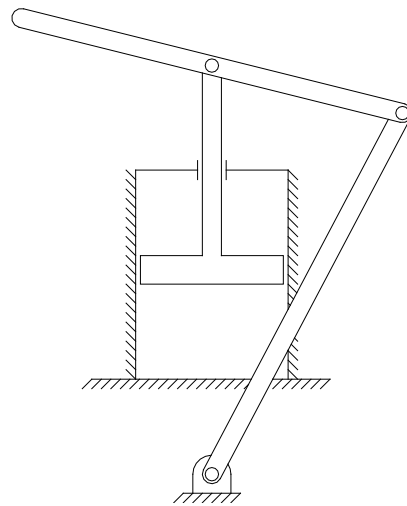

Pump Mechanism S-C Inversion 4

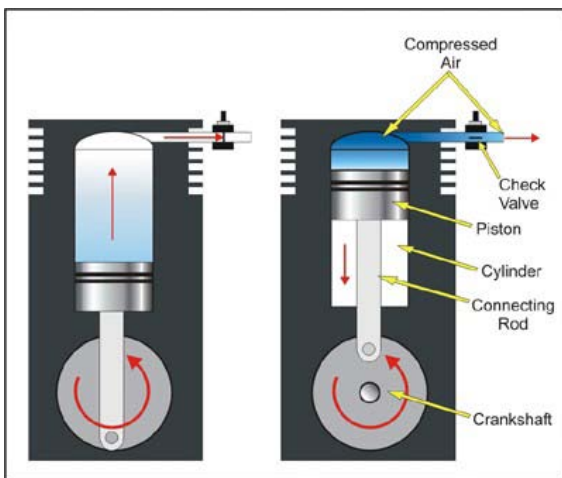

Air Compressor Mechanism S-C Inversion 1

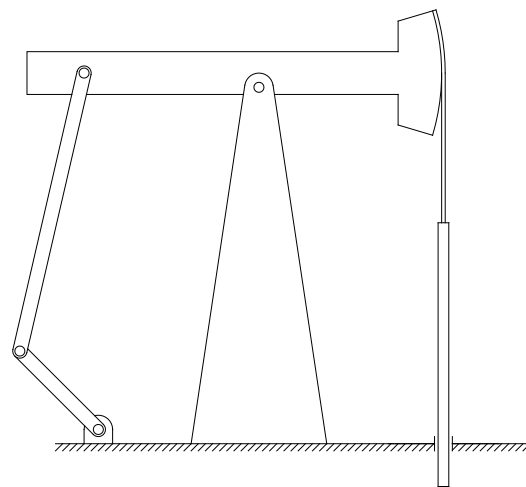

5-bar Oil Well Pump Mechanism

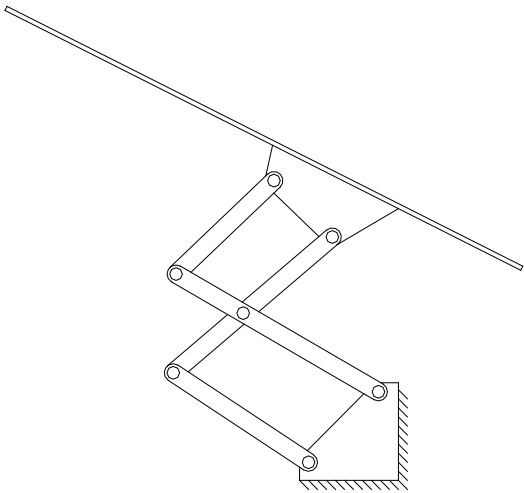

6-bar Car Hood Mechanism

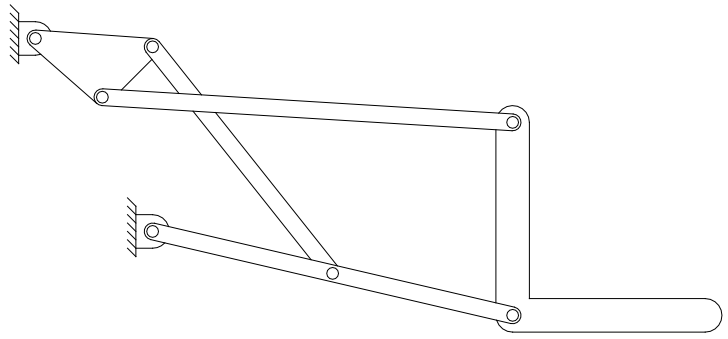

6-bar Lift Mechanism

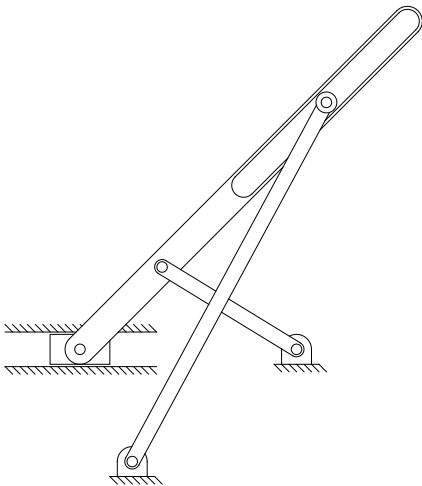

6-bar Window Mechanism

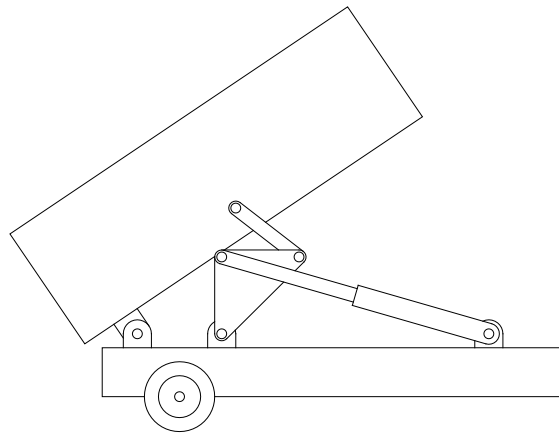

6-bar Dump Truck Mechanism

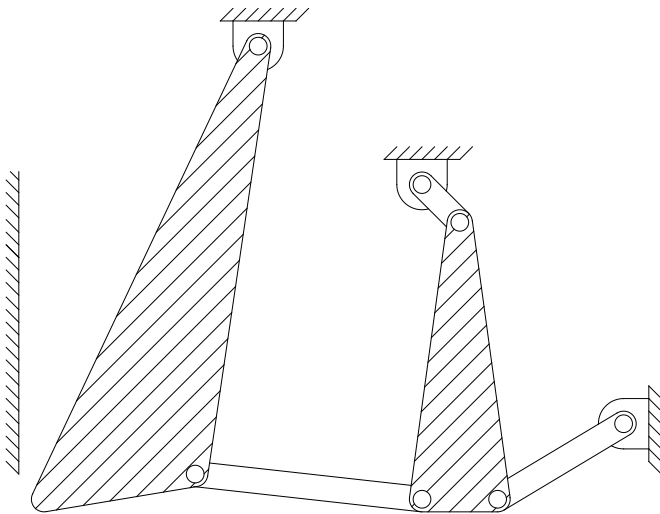

6-bar Rock Crusher Mechanism

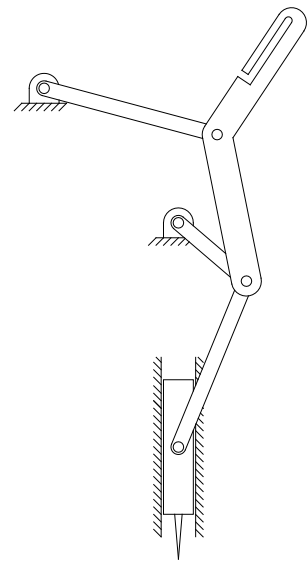

6-bar Sewing Machine Mechanism

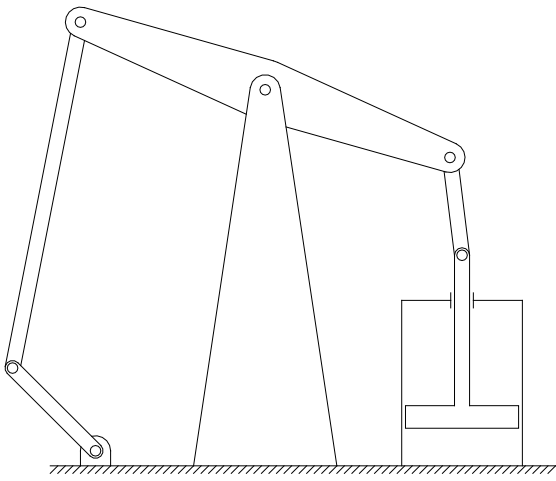

6-bar Watt Steam Engine Mechanism

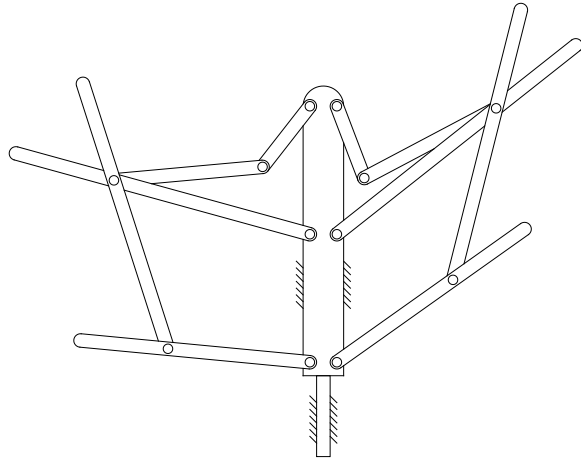

Dual 6-bar Mechanism Collapsible Music Stand

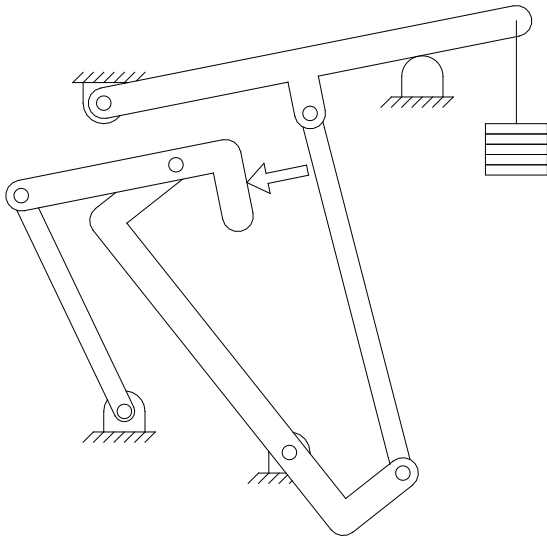

6-bar Leg Press Mechanism

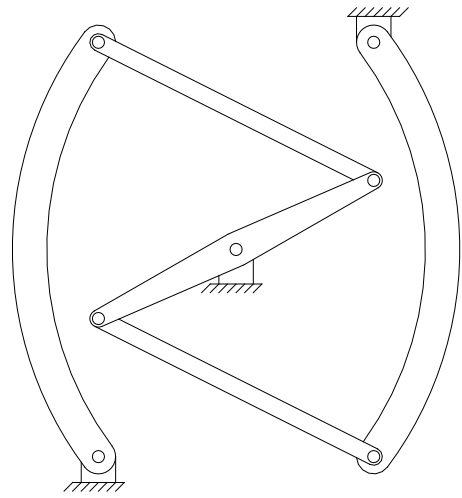

6-bar Drum Brake Mechanism

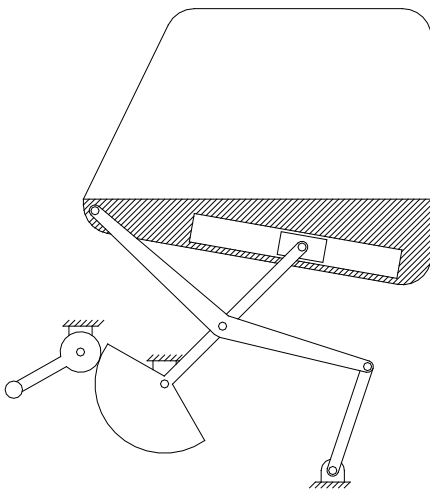

7-bar Car Window Mechanism

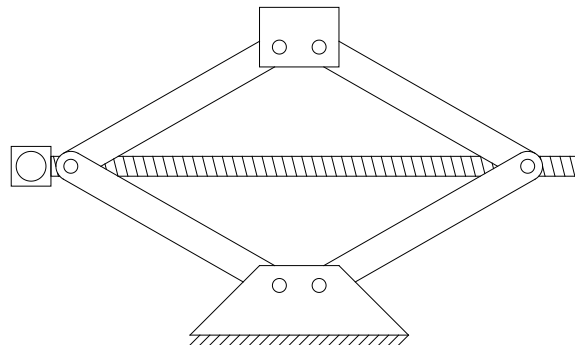

7-bar Car Jack Mechanism

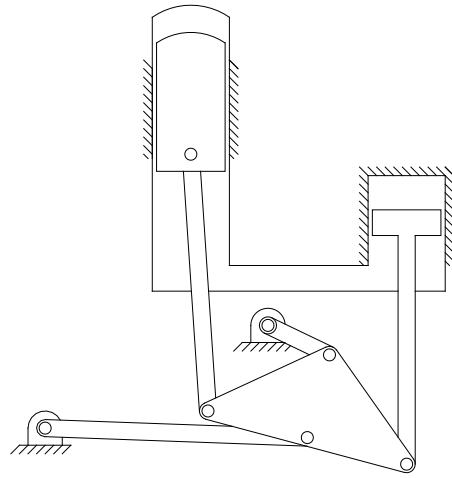

7-bar Ross Stirling Engine Mechanism

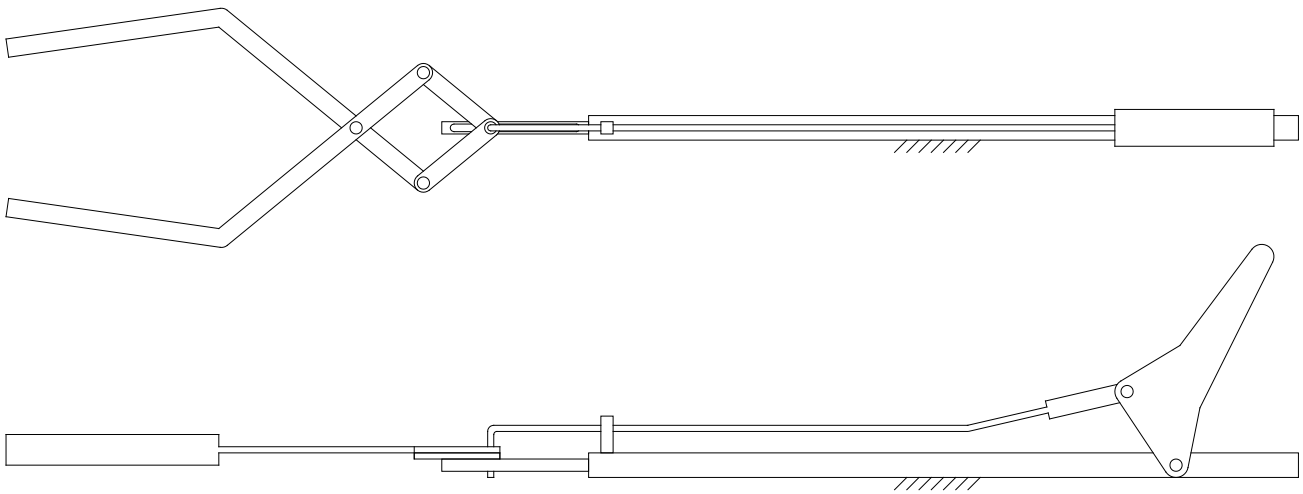

7-bar Grabber/Extender Compound Mechanism

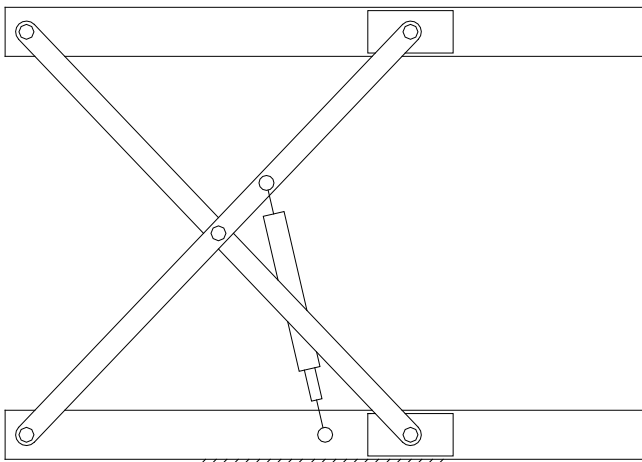

8-bar Scissor-Lift Mechanism

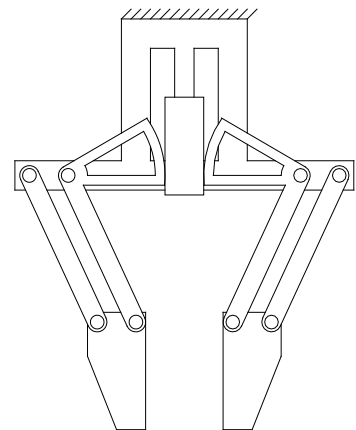

8-bar Robot Gripper Mechanism

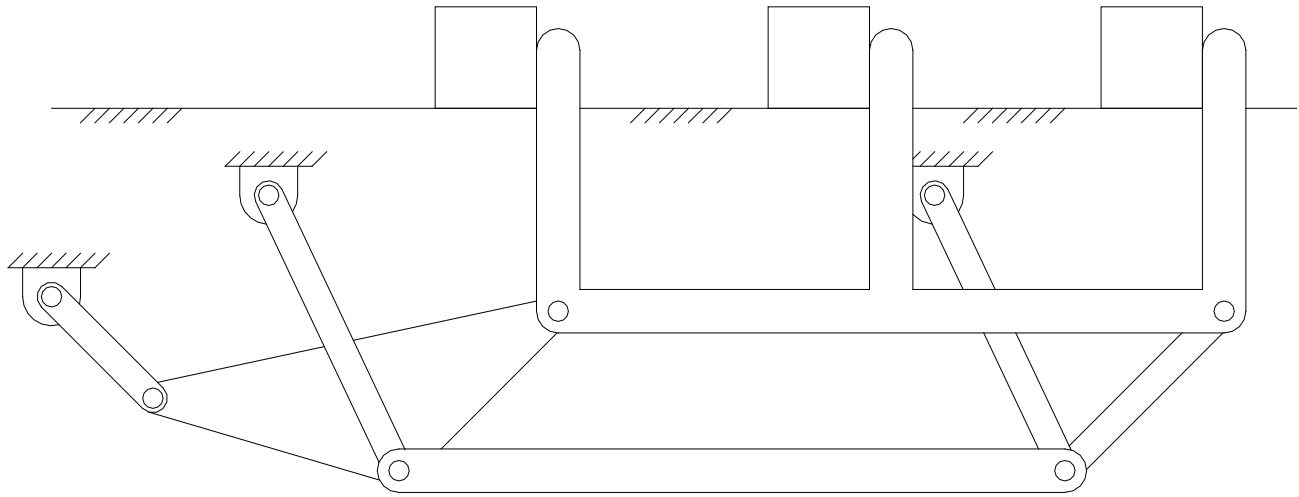

8-Bar Straight-Line Transfer Mechanism

Multi-dof Robots

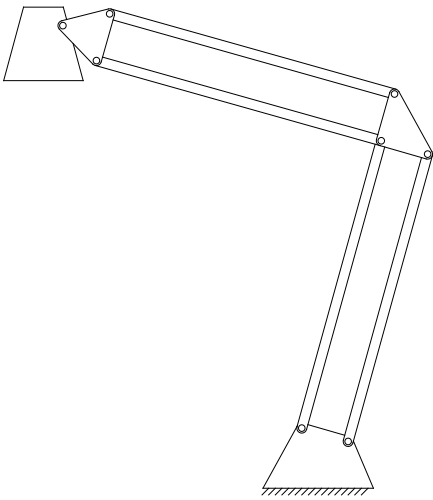

3-dof 8-bar Desk Lamp Robot

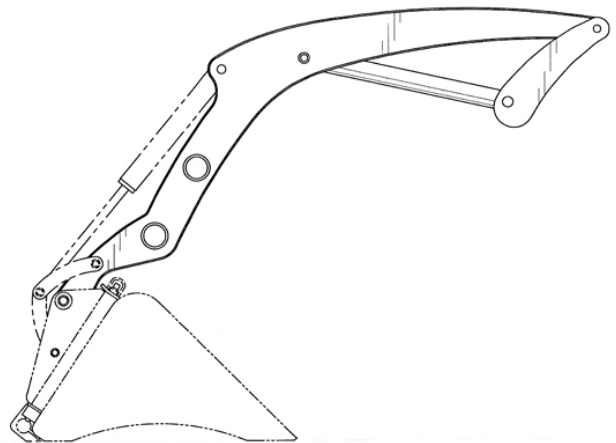

2-dof 9-bar Front-End Loader Robot

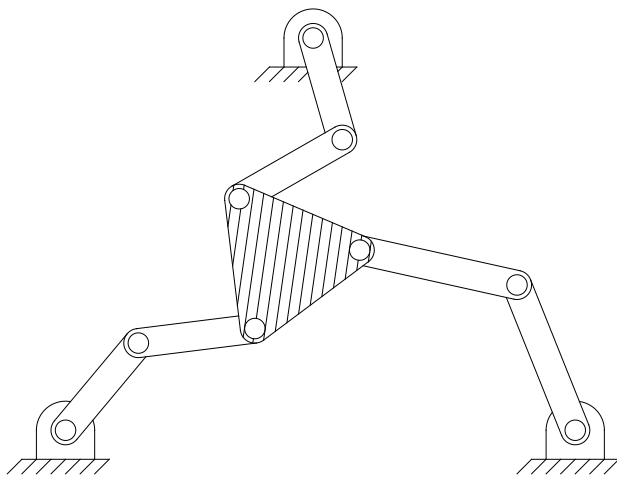

3-dof 3-RRR Parallel Robot

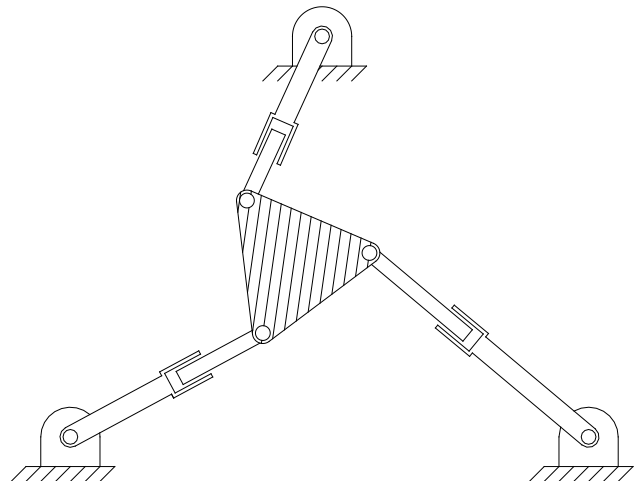

3-dof 3-RPR Parallel Robot

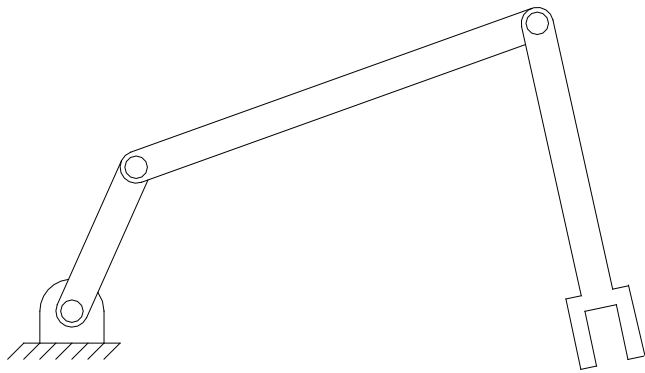

Planar 3-dof Robot



Adept 4-dof SCARA Robot



Mitsubishi 5-dof Robot



PUMA 6-dof Robot

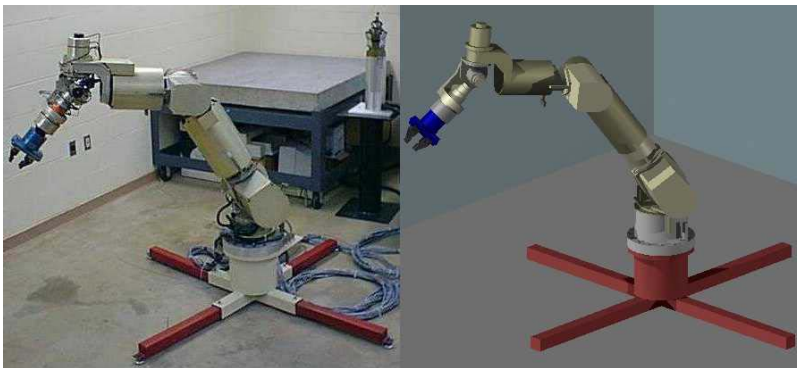

NASA 8-dof ARMII Robot

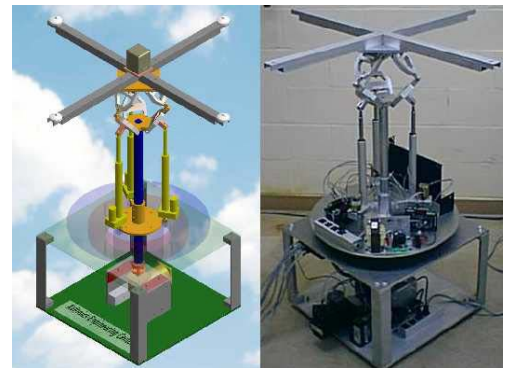

3-dof Carpal Wrist Robot

Real-World Mechanisms / Kinematic Diagrams

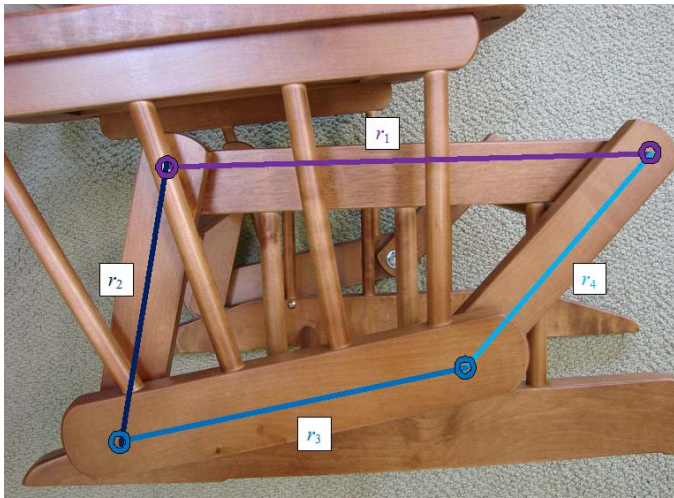

4-bar Glider-Rocker Mechanism

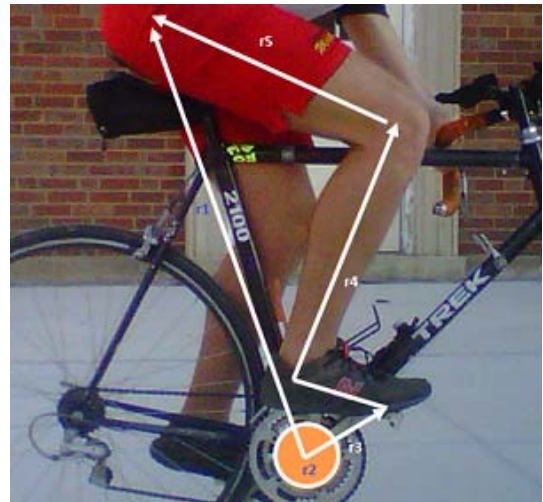

Bicycle/Human Leg 4-bar Mechanism (lock ankle)

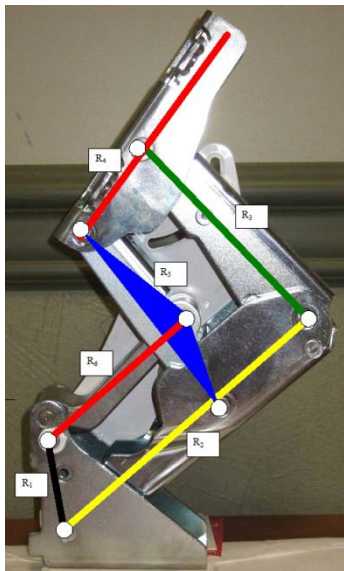

Hettich Hinge Watt I 6-bar Mechanism



Mountain Bike Rear Suspension Mechanism

MATLAB Simulation/Animation Gallery

All of the following MATLAB graphics/animations were created by Dr. Bob at Ohio University. These are presented according to the Ohio University course they support.

ME 301 Kinematics & Dynamics of Machines

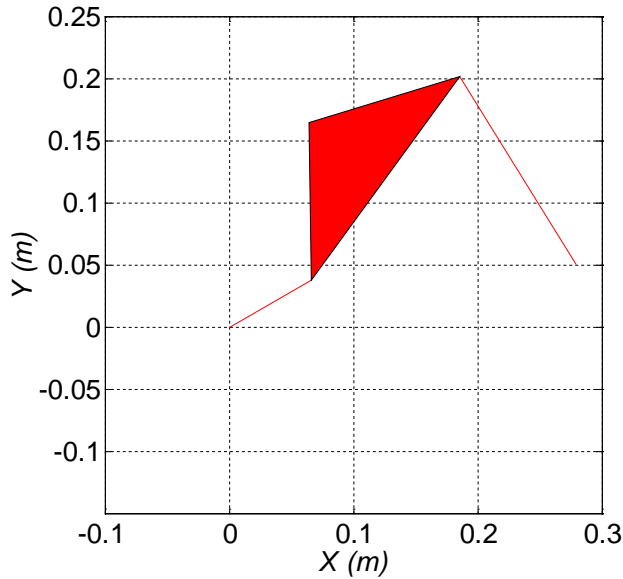

Open Branch

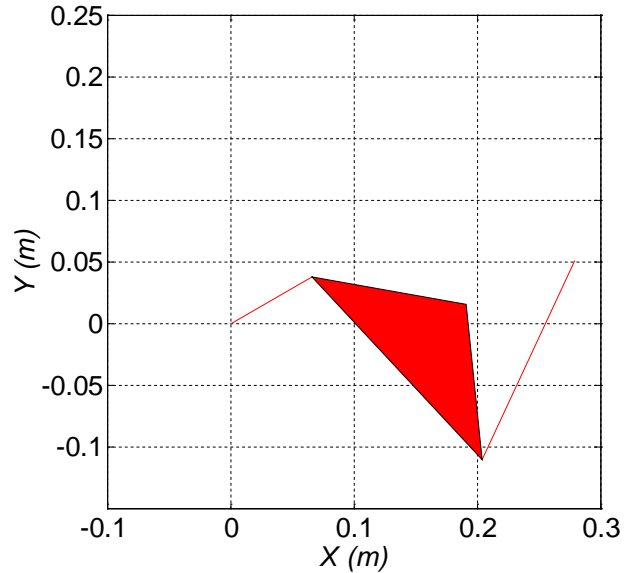

Crossed Branch

Four-Bar Mechanism

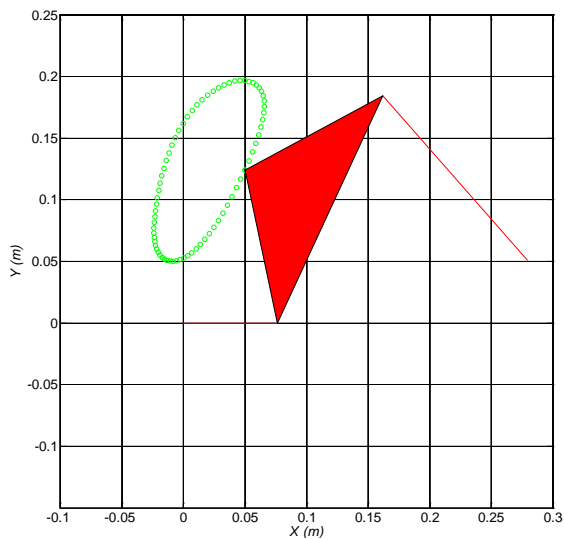

Four-Bar Mechanism Coupler Curve

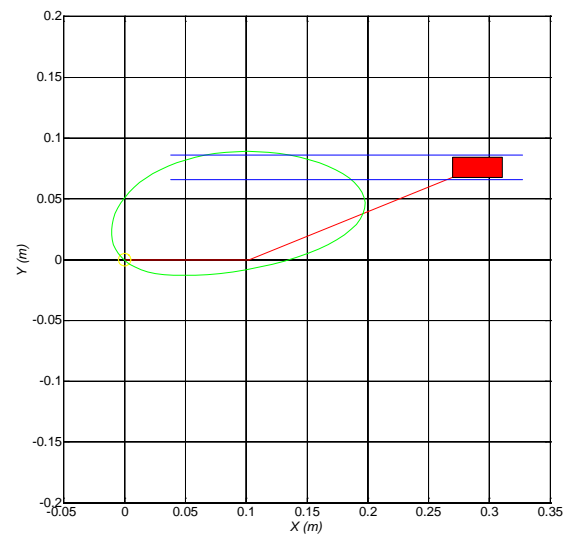

Slider-Crank Mechanism

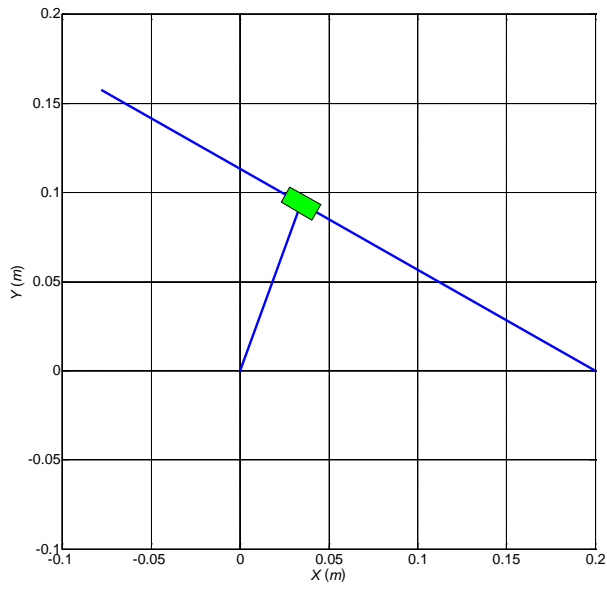

Slider-Crank Mechanism, Inversion 2

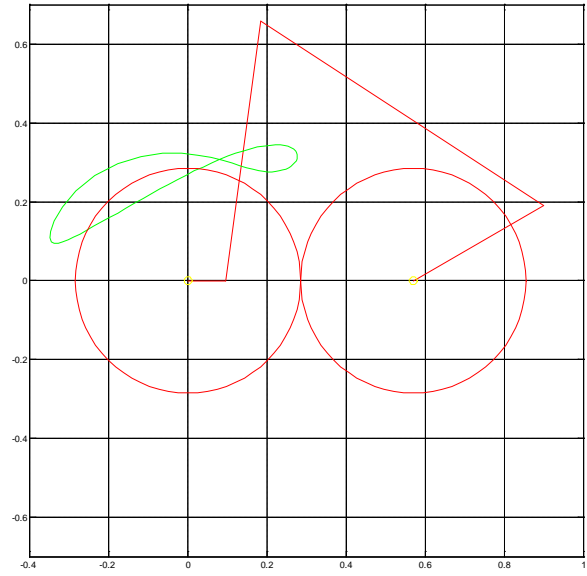

Geared Five-Bar Mechanism

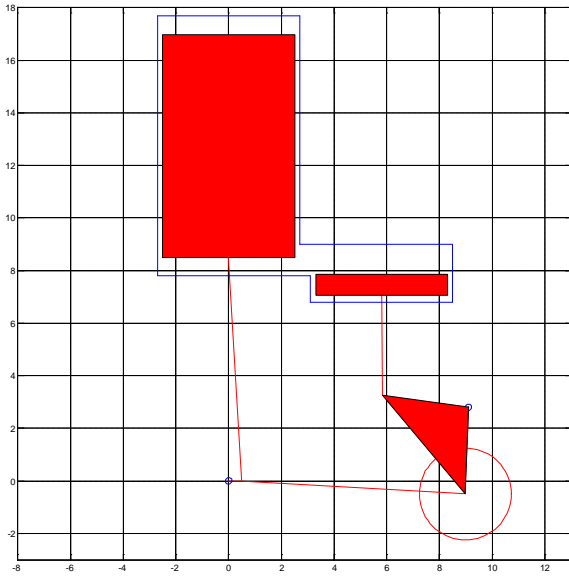

Ross-Yoke Stirling Engine Mechanism

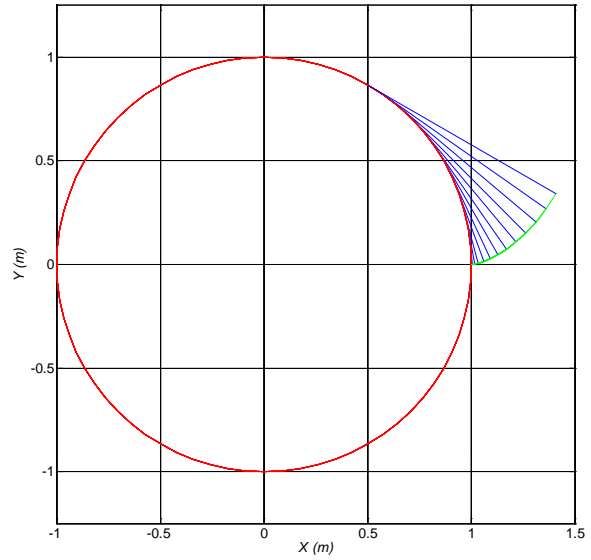

Involute Gear Tooth Construction

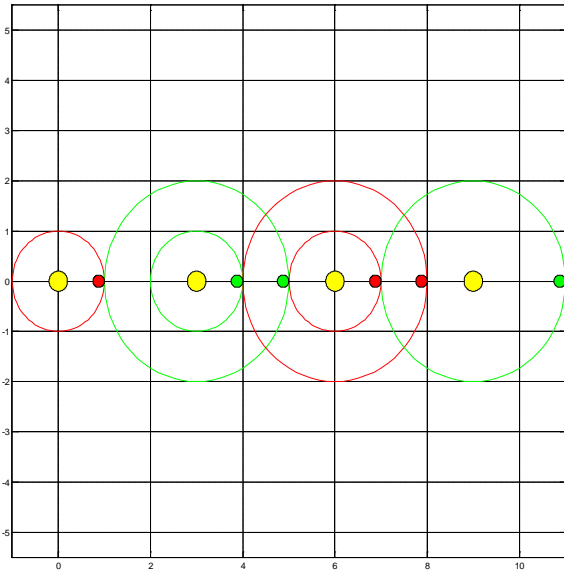
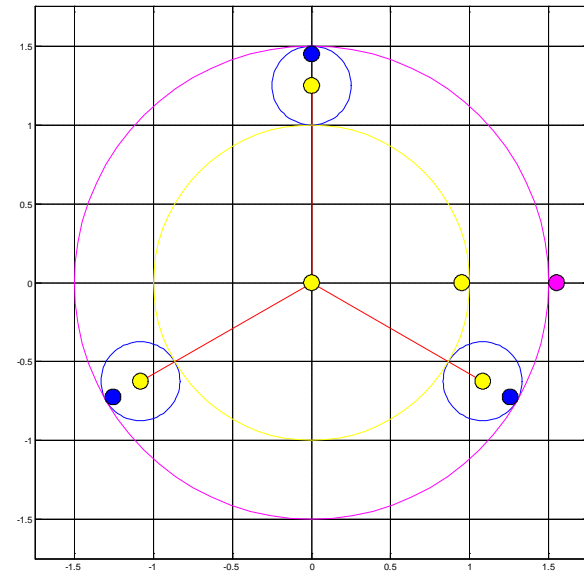
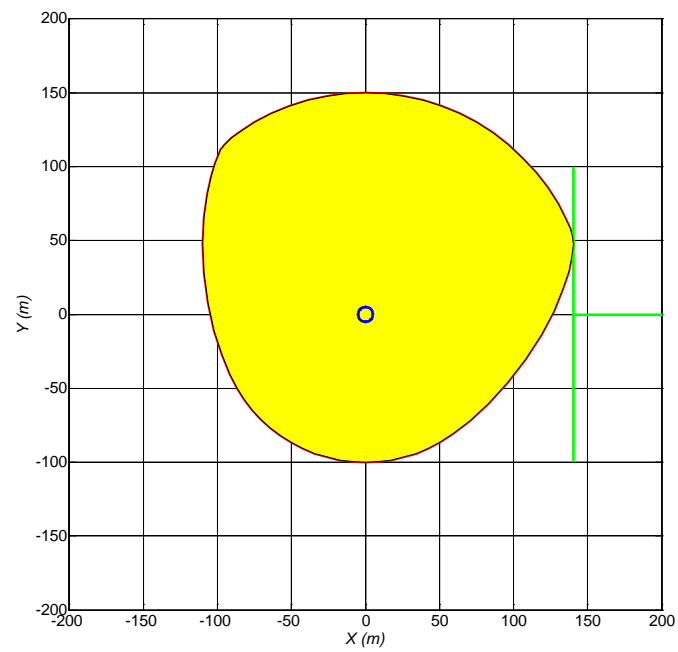
**Gearbox Simulation****Planetary Gear Train Simulation****Cam/Follower Animation**

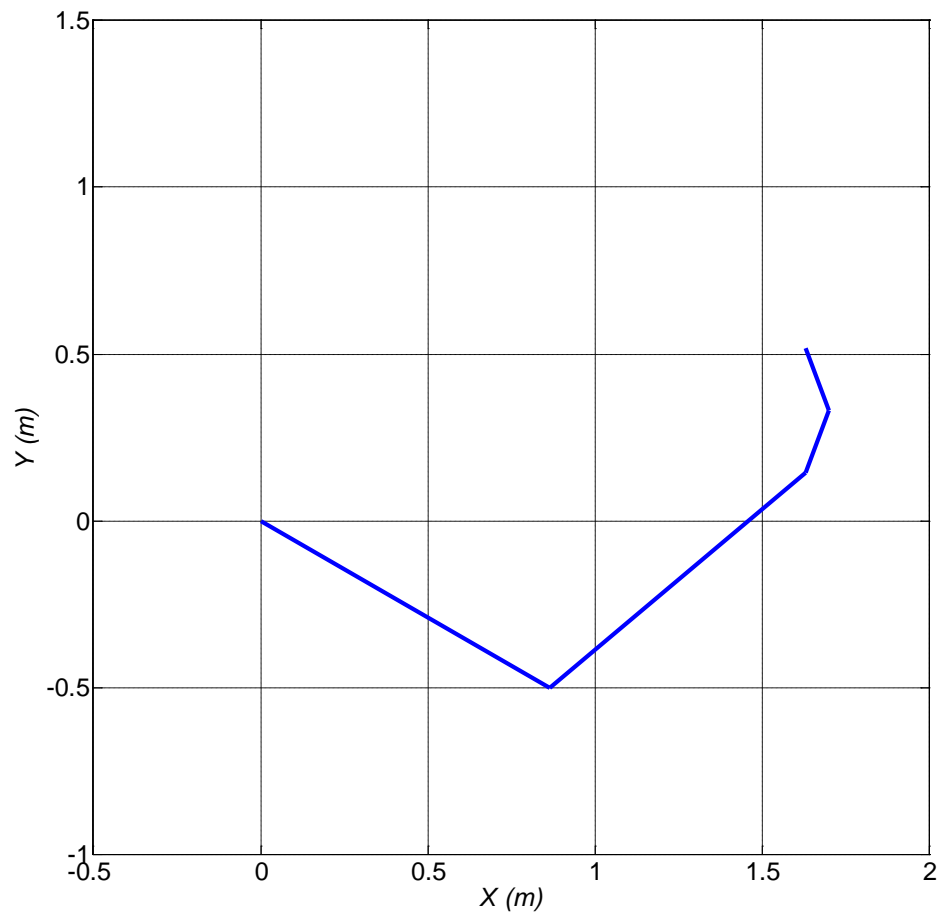
EE/ME 429/529 Mechanics of Robotic Manipulators**Planar 4R Kinematically-Redundant Robot Resolved-Rate Control Simulation**

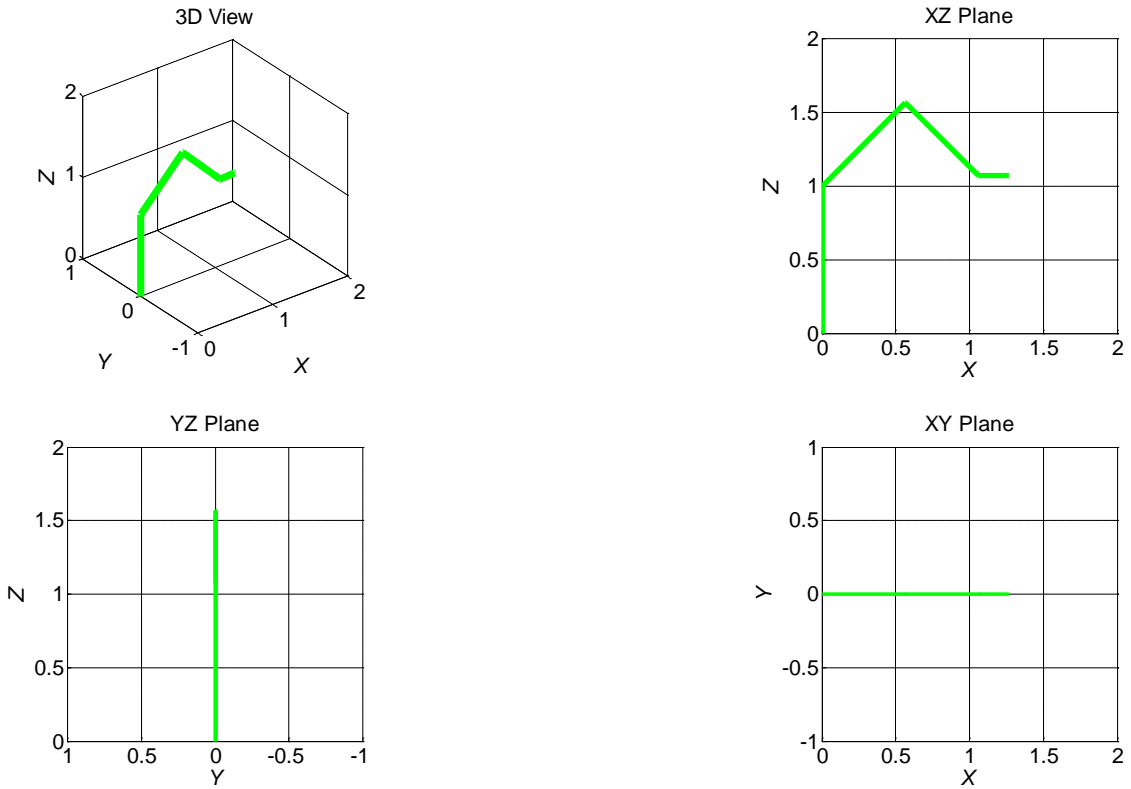

Spatial 4R Kinematically-Redundant Robot Resolved-Rate Control Simulation

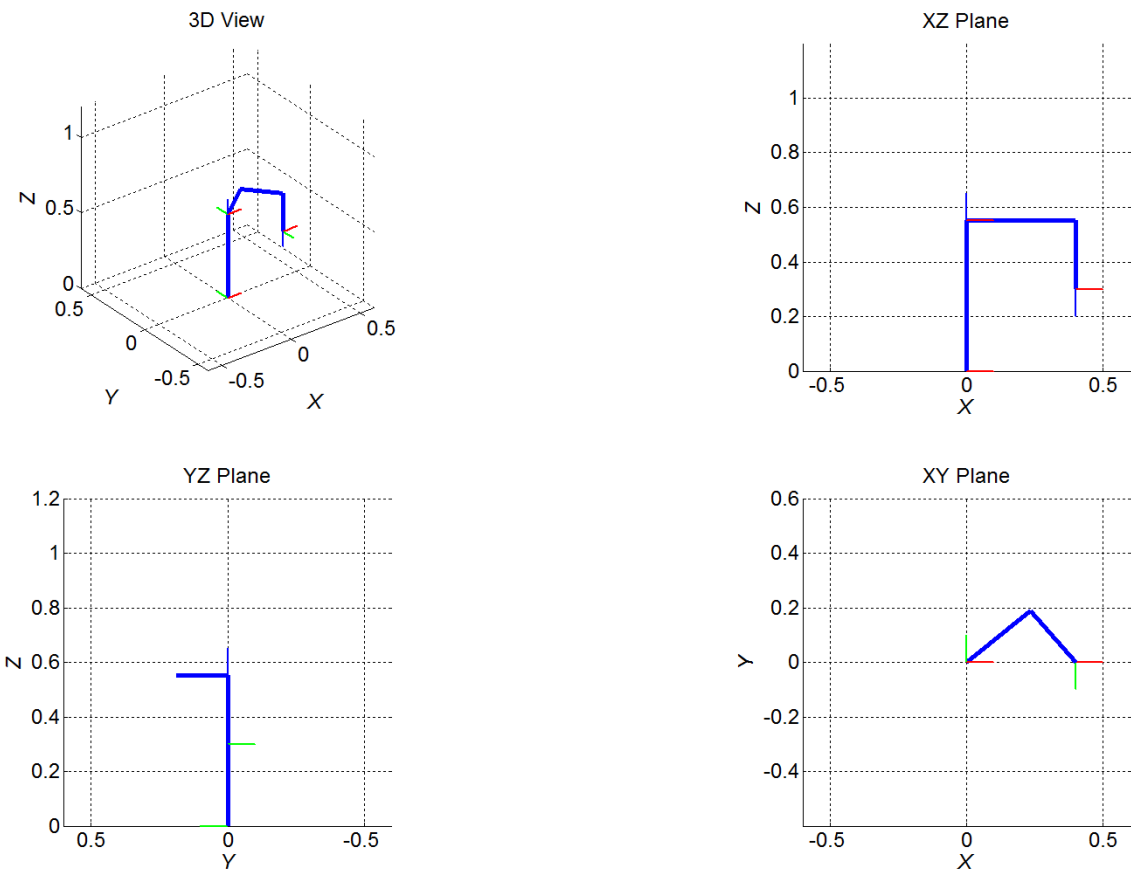

Adept 550 4-dof SCARA Robot MATLAB Simulation/Animation

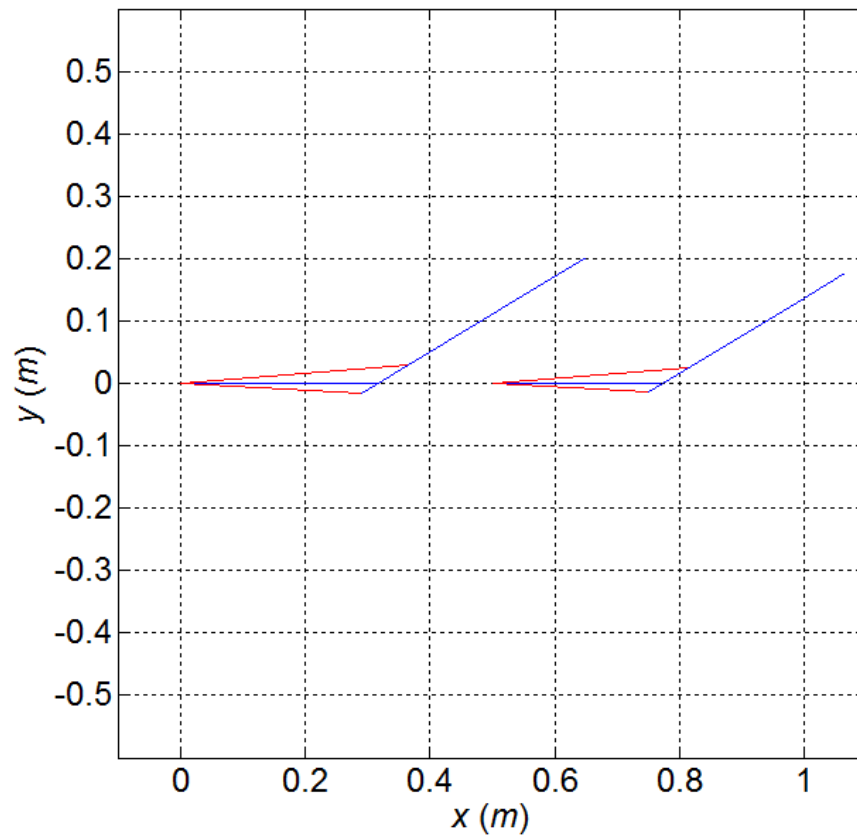
ME 467 / BME 567 Biomechanics of Human Motion**Human Elbow/Biceps/Triceps Dynamic Simulation (male left, female right)**

ME 491 Mechanical Vibrations

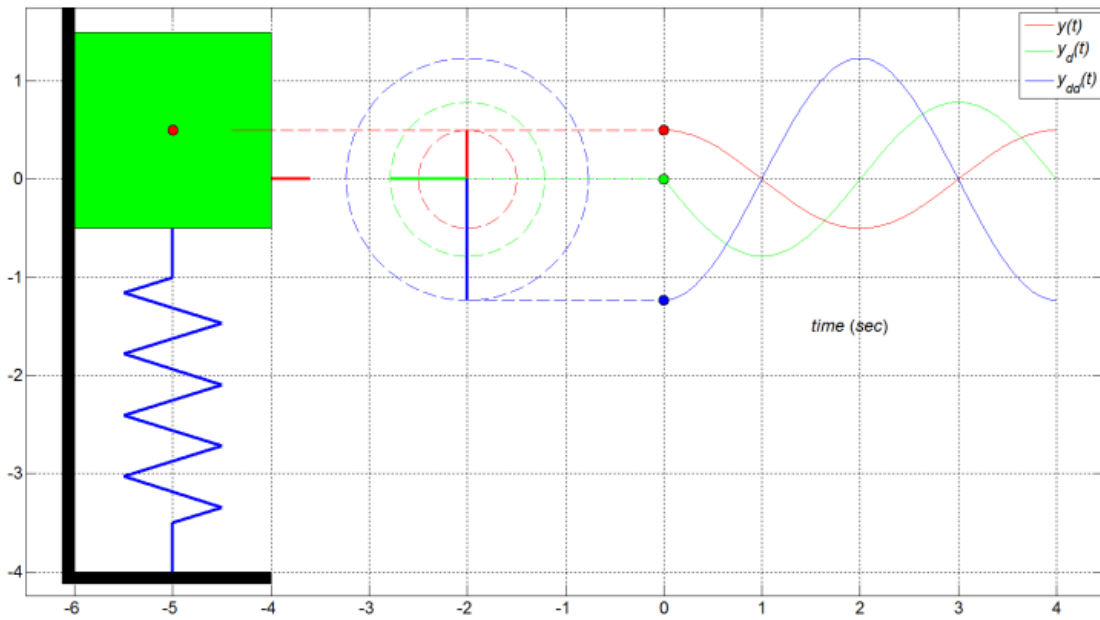

1-dof m-k Vibrational System, Simple Harmonic Motion

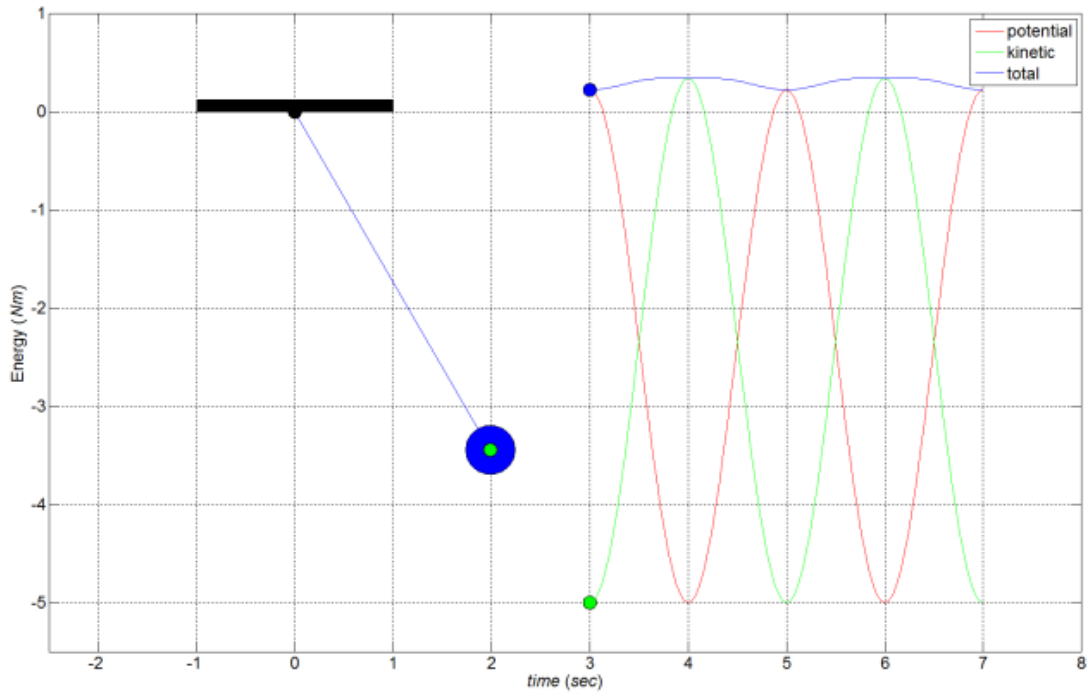

1-dof Pendulum Vibrational System, Simple Harmonic Motion