

WIRING DIAGRAMS

1990 Volvo 740

1990 WIRING DIAGRAMS
Volvo

740

IDENTIFICATION

COMPONENT LOCATION TABLE

COMPONENT LOCATIONS TABLE

Component	Figure No. (Location)
A/C COMP (ECC)	7 (E 25)
A/C COMP (STD)	7 (B 25)
A/C CTRL SW (STD)	7 (C-B 24)
ABS SYSTEM	9 (A-B 32-35)
ALTERNATOR	1 (C 3)
ANTENNA MOTOR	12 (E 46)
BACK-UP LT SW	12 (C 46)
BATTERY	1 (A 2)
BEAM LENGTH REGULATOR	6 (A 23)
BULB FAILURE SENS	8 (E 28)
COMB SW	8 (A-B 28)
COOLANT FAN RLY	6 (A 20)
COURTESY LTS	8 (C 28)
CRUISE CTRL SYSTEM	9 (C 32-33)
DEFOG SW	12 (A-B 44)
DELAY RELAY	7 (C 27)
DOOR LIGHTS	8 (D 28)
ECC CTRL UNIT	7 (C-E 27)
ENGINE COMPT LT	1 (E 2)
FLASHER UNIT	8 (A 31)
FNT FOG LT SW	9 (E 32)
FRONT FOG RELAY	9 (E 35)
FUEL INJ ECU (16 VALVE)	4 (A-C 12)
FUEL INJ ECU (8 VALVE)	3 (A-C 8)
FUEL INJ ECU (REGINA)	2 (A-C 4)
FUEL INJ ECU (TURBO)	5 (A-C 16)
FUEL PUMP (MAIN) (16 VALVE)	4 (D 12)
FUEL PUMP (MAIN) (8 VALVE)	3 (D 8)
FUEL PUMP (MAIN) (REGINA)	2 (D 4)
FUEL PUMP (MAIN) (TURBO)	5 (C 19)
FUEL PUMP (TANK) (16 VALVE)	4 (D 12)
FUEL PUMP (TANK) (8 VALVE)	3 (D 8)
FUEL PUMP (TANK) (REGINA)	2 (D 4)
FUEL PUMP (TANK) (TURBO)	5 (B-C 19)
FUEL SYSTEM RELAY (16 VALVE)	4 (C 12)
FUEL SYSTEM RELAY (8 VALVE)	3 (C 8)
FUEL SYSTEM RELAY (REGINA)	2 (C 4)
FUEL SYSTEM RELAY (TURBO)	5 (C 19)
FUSE & RELAY BLOCK (PARTIAL)	6 (B-D 20-23)
GLOVE BOX LT	8 (E 29)
HEATER CTRL SW	7 (C 24)
HEATER FAN MTR	7 (E 24)
HEATER FAN PRES SENS	7 (B 27)
HIGH LEVEL STOP LT	12 (D 46)
IGN COIL (8 VALVE)	3 (E 10)
IGN COIL (16 VALVE)	4 (E 14)

IGN COIL (TURBO)	5 (C 16)
IGN SW	6 (E 20)
IGN SYSTEM ECU (8 VALVE)	3 (C-D 11)
IGN SYSTEM ECU (16 VALVE)	4 (C-D 15)
IGN SYSTEM ECU (REGINA)	2 (C-D 7)
IGN SYSTEM ECU (TURBO)	5 (C-D 16)
INHIBITOR SW	1 (B 2)
INST CLSTR	10 (A-E 36)
INTERVAL RELAY	8 (D 31)
LEFT FNT DOOR SW	8 (C 30)
LEFT FNT PWR SEAT SW	11 (B-D 43)
LEFT HEADLT ADJUSTING MTR	1 (C-D 1)
LEFT HEADLT WIPER MTR	1 (E 3)
LIGHT RELAY	8 (B-C 31)
LIGHT SW	8 (A-B 31)
LOCKING RLY	11 (E 43)
O2 SENS (8 VALVE)	3 (C 11)
O2 SENS (REGINA)	2 (C 7)
O2 SENS (16 VALVE)	4 (C 15)
O2 SENS (TURBO)	5 (C 19)
OVERDRIVE RELAY	7 (A-B 24)
POWER STAGE (16 VALVE)	4 (E 15)
POWER STAGE (8 VALVE)	3 (E 11)
POWER STAGE (TURBO)	5 (E 19)
POWER WDO/HEATED SEAT RLY	7 (B 24)
RADIO INTERFERENCE SUPPRESSION RLY (16 VALVE)	4 (B 15)
RADIO INTERFERENCE SUPPRESSION RLY (8 VALVE)	3 (B 11)
RADIO INTERFERENCE SUPPRESSION RLY (REGINA)	2 (B 7)
RADIO INTERFERENCE SUPPRESSION RLY (TURBO)	6 (C-D 19)
REAR FOG LT RLY	9 (E 32)
REAR FOG LT SW	9 (D 32)
REAR INTERVAL RELAY	12 (C 44)
REAR SEAT HTR LT	11 (A 41)
REAR SW	11 (D-E 40)
REAR WIPER/WASHER SW	8 (D-E 31)
REX I POWER STAGE/IGN COIL	2 (E 7)
RIGHT FNT WDO SW	11 (E 41)
RIGHT HEADLT ADJUSTING MTR	1 (B-C 1)
RIGHT HEADLT WIPER MTR	1 (E 3)
RIGHT POWER MIRROR SW	12 (D-E 44)
SEAT BELT LOCK LTS	11 (A-B 40)
SEAT BELT REMINDER	11 (A 40)
SEAT HTR SW & LT (DUAL)	11 (C 40)
SEAT HTR SW & LT (SINGLE OUTPUT)	11 (A 43)
SEAT THERMOSTAT (DUAL)	11 (C 40)
SRS SYSTEM	9 (C-D 35)
STARTER	1 (B-C 3)
STOP LT SW	9 (D 32)
SUNROOF SW	12 (E 44)
SUPPLEMENTARY HI BEAM RLY	9 (D-E 35)
TRUNK LT	12 (D 46)
WASHER MOTOR	1 (D 3)
WIPER MOTOR	1 (D 3)
WIPER/WASHER SW	8 (C 31)

WIRING DIAGRAMS

COMPONENT LOCATOR:

A/C COMP (ECC)	E 25
A/C COMP (STD)	E 25
A/C CTRL SW (STD)	C-B 24
ABS SYSTEM	A-B 32-36
ALTERNATOR	C 3
ANTENNA MTR	E 48
BACK-UP LT SW	C 46
BATTERY	A 2
BEAM LENGTH REGULATOR	A 23
BULB FAILURE SENS	E 28
COMB SW	A-B 28
COOLANT FAN RLY	A-B 44
COURTESY LTS	C 28
CRUISE CTRL SYSTEM	C 32-33
DEFOG SW	A-B 44
DELAY RLY	C 27
DOOR LTS	D 28
EOC CTRL UNIT	C-E 27
ENGINE COMPT LT	E 2
FLASHER UNIT	A 31
FRONT FOG LT SW	E 32
FRONT FOG RLY	E 35
FUEL INJ ECU (16 VALVE)	A-C 12
FUEL INJ ECU (8 VALVE)	A-C 2
FUEL INJ ECU (REGINA)	A-C 4
FUEL INJ ECU (TURBO)	A-C 16
FUEL PUMP (MAIN) (16 VALVE)	D 12
FUEL PUMP (MAIN) (REGINA)	D 4
FUEL PUMP (MAIN) (TURBO)	C 19
FUEL PUMP (TANK) (16 VALVE)	D 12
FUEL PUMP (TANK) (8 VALVE)	D 4
FUEL PUMP (TANK) (REGINA)	D 4
FUEL PUMP (TANK) (TURBO)	B-C 19
FUEL SYS RLY (16 VALVE)	C 4
FUEL SYS RLY (8 VALVE)	C 4
FUEL SYS RLY (REGINA)	C 4
FUEL SYS RLY (TURBO)	C 15
FUSE/RELAY BLOCK (PARTIAL)	B-D 20-23
GLOVE BOX LT	E 39
HEATER CTRL SW	C 24
HEATER FAN MTR	E 24
HEATER FAN PRES SENS	B 27
HIGH LEVEL STOP LT	D 46
IGN COIL (16 VALVE)	E 14
IGN COIL (8 VALVE)	E 10
IGN COIL (TURBO)	C 16
IGN SW	C 16
IGN SYS ECU (16 VALVE)	C-D 15
IGN SYS ECU (8 VALVE)	C-D 11
IGN SYS ECU (REGINA)	C-D 7
IGN SYS ECU (TURBO)	C-D 10
INHIBITOR SW	B 2
INST CLSTR	A-E 36
INTERNAL RLY	D 31
LEFT FNT DOOR SW	C 30
LEFT FNT PWR SEAT SW	B-D 43
LEFT HEADLT ADJUSTING MTR	C-D 1
LEFT HEADLT WIPER MTR	E 3
LIGHT SW	B-C 31
LOCKING RLY	A-B 31
O2 SENS (16 VALVE)	C 15
O2 SENS (8 VALVE)	C 11
O2 SENS (REGINA)	C 7
O2 SENS (TURBO)	C 19
OVERDRIVE RLY	A-B 24
POWER STAGE (16 VALVE)	E 15
POWER STAGE (8 VALVE)	E 11
POWER STAGE (TURBO)	E 19
POWER WID/HEATED SEAT RLY	B 24
RADIO INTERFERENCE SUPPRESSION RLY (16 VALVE)	B 15
RADIO INTERFERENCE SUPPRESSION RLY (8 VALVE)	B 11
RADIO INTERFERENCE SUPPRESSION RLY (REGINA)	B 7
RADIO INTERFERENCE SUPPRESSION RLY (TURBO)	C-D 19
REAR FOG LT MTR	E 32
REAR FOG LT SW	D 32
REAR INTERVAL RLY	C 44
REAR SEAT HTR LT	A 41
REAR SW	D-E 40
REAR WIPER/WASHER SW	D-E 31
REX I POWER STAGE/IGN COIL	E 7
RIGHT FNT WDO SW	B-C 41
RIGHT HEADLT ADJUSTING MTR	B-C 1
RIGHT HEADLT WIPER MTR	E 3
RIGHT PWR MIRROR SW	D-E 44
SEAT BELT LOCK LTS	A-B 40
SEAT BELT REMINDER	A 40
SEAT HTR SW \$ LT (DUAL)	C 40
SEAT HTR SW \$ LT (SINGLE OUTPUT)	C 40
SEAT THERMOSTAT (DUAL)	C 40
SRS SYSTEM	C-D 35
STARTER	B-C 3
STOP LT SW	D 32
SUNROOF SW	E 44
SUPPLEMENTARY HI BEAM RLY	D-E 35
TRUNK LT	D 46
WASHER MTR	D 3
WIPER MTR	D 3
WIPER/WASHER SW	C 31

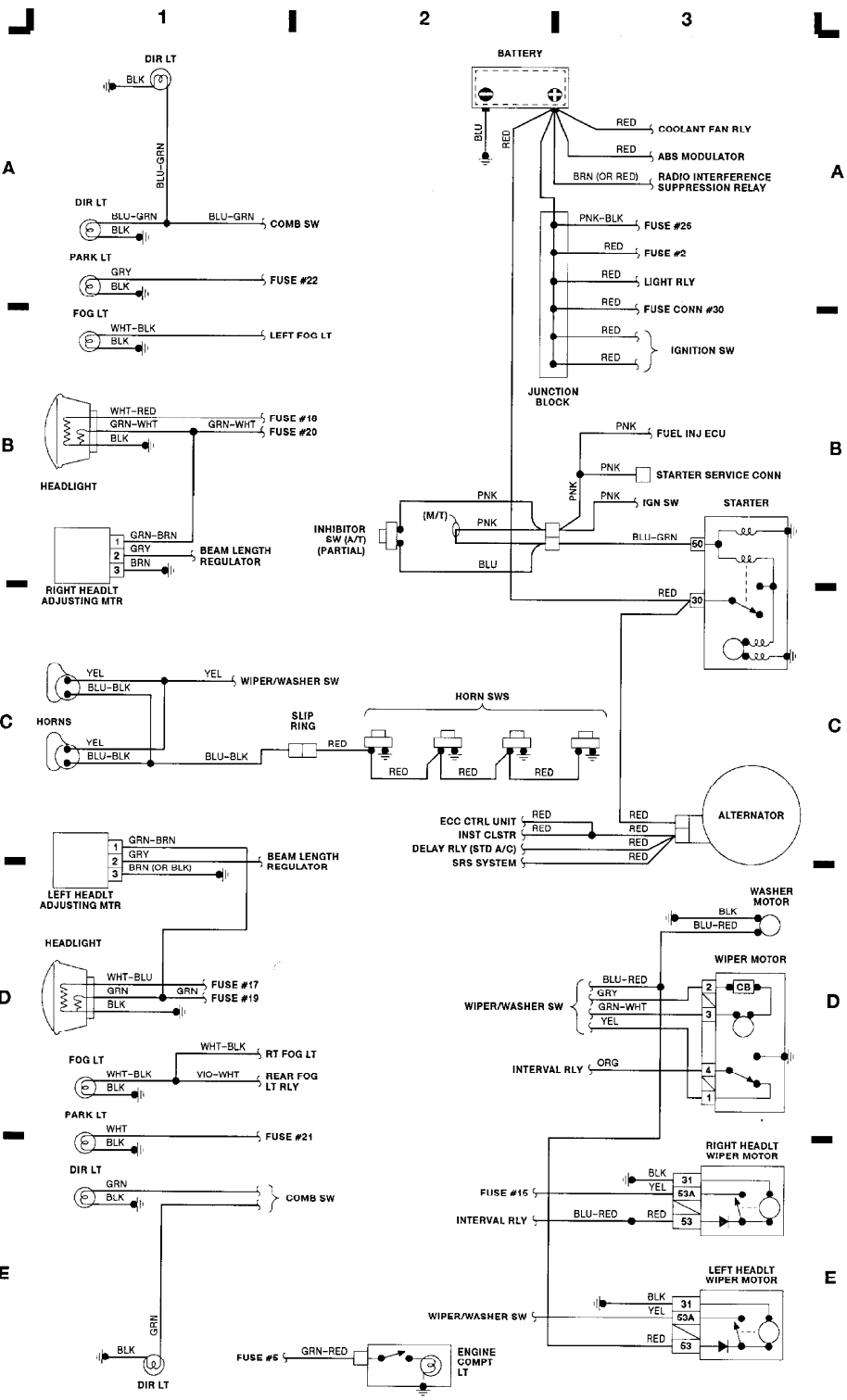

90J21930

Fig. 1: Engine Compartment & Headlights (Grids 1-3)

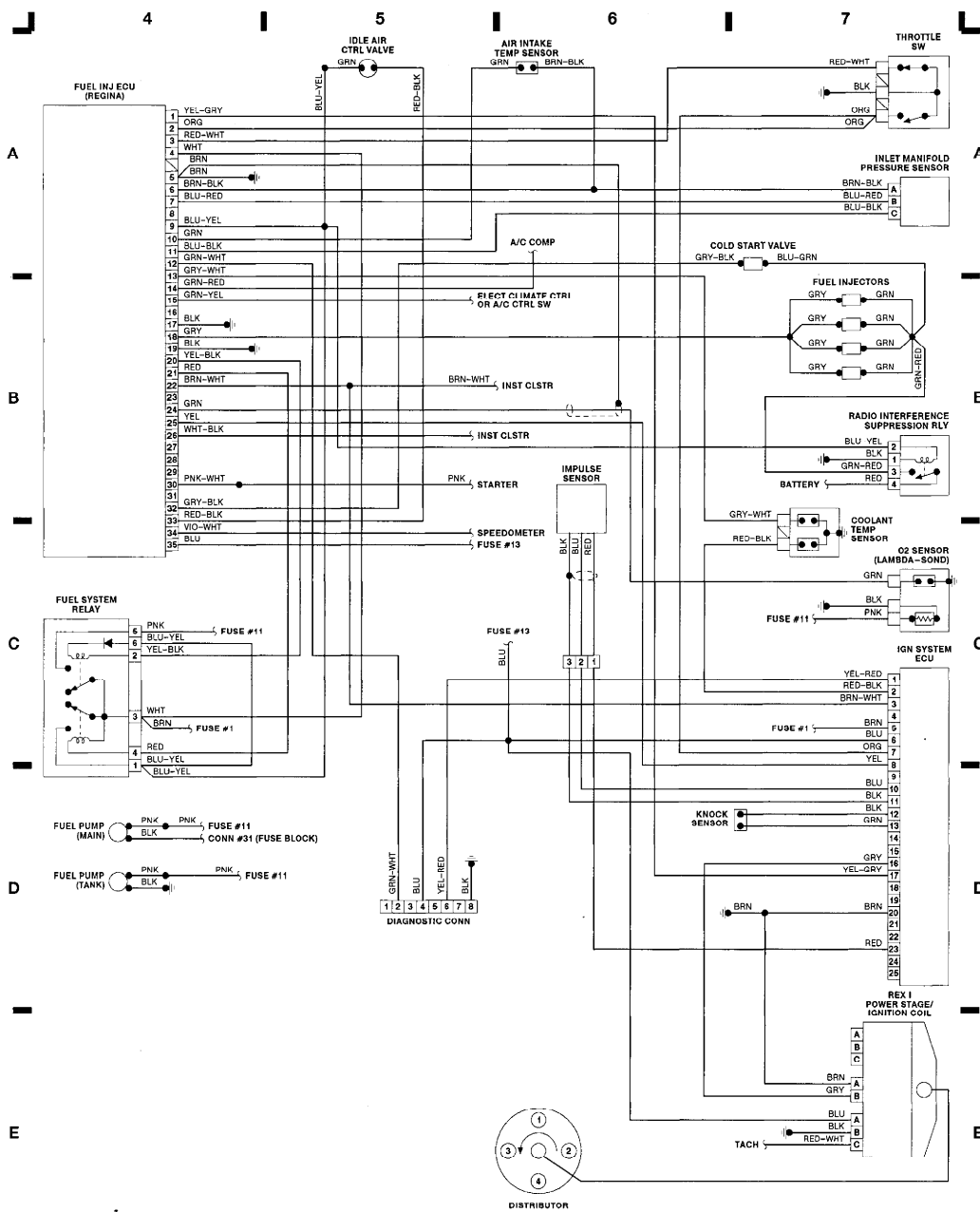

90A21931
 Fig. 2: Computer Engine Control (Regina) (Grids 4-7)

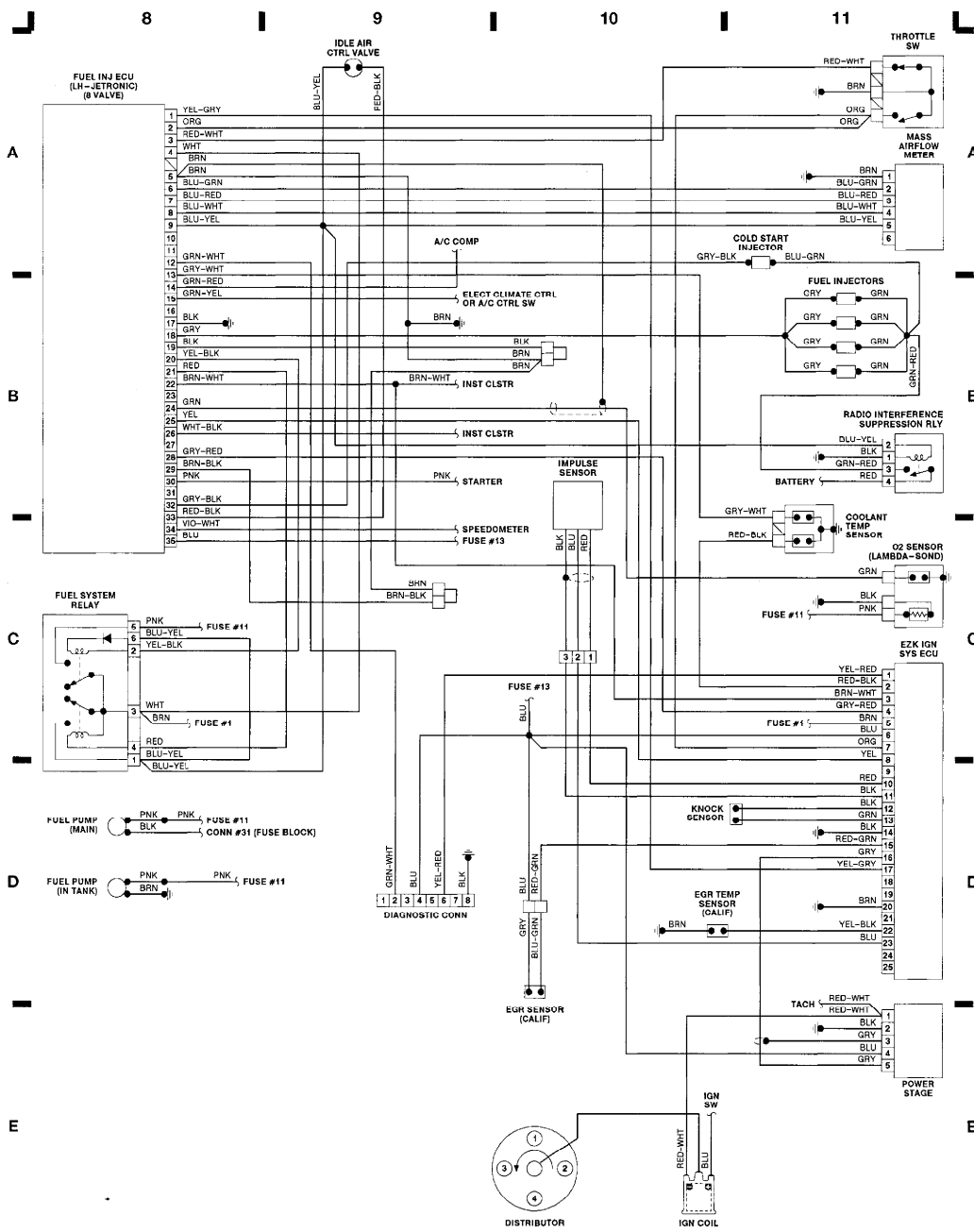

90B21932
 Fig. 3: Computer Eng Control (LH Jetronic 8 Valve) (Grids 8-11)

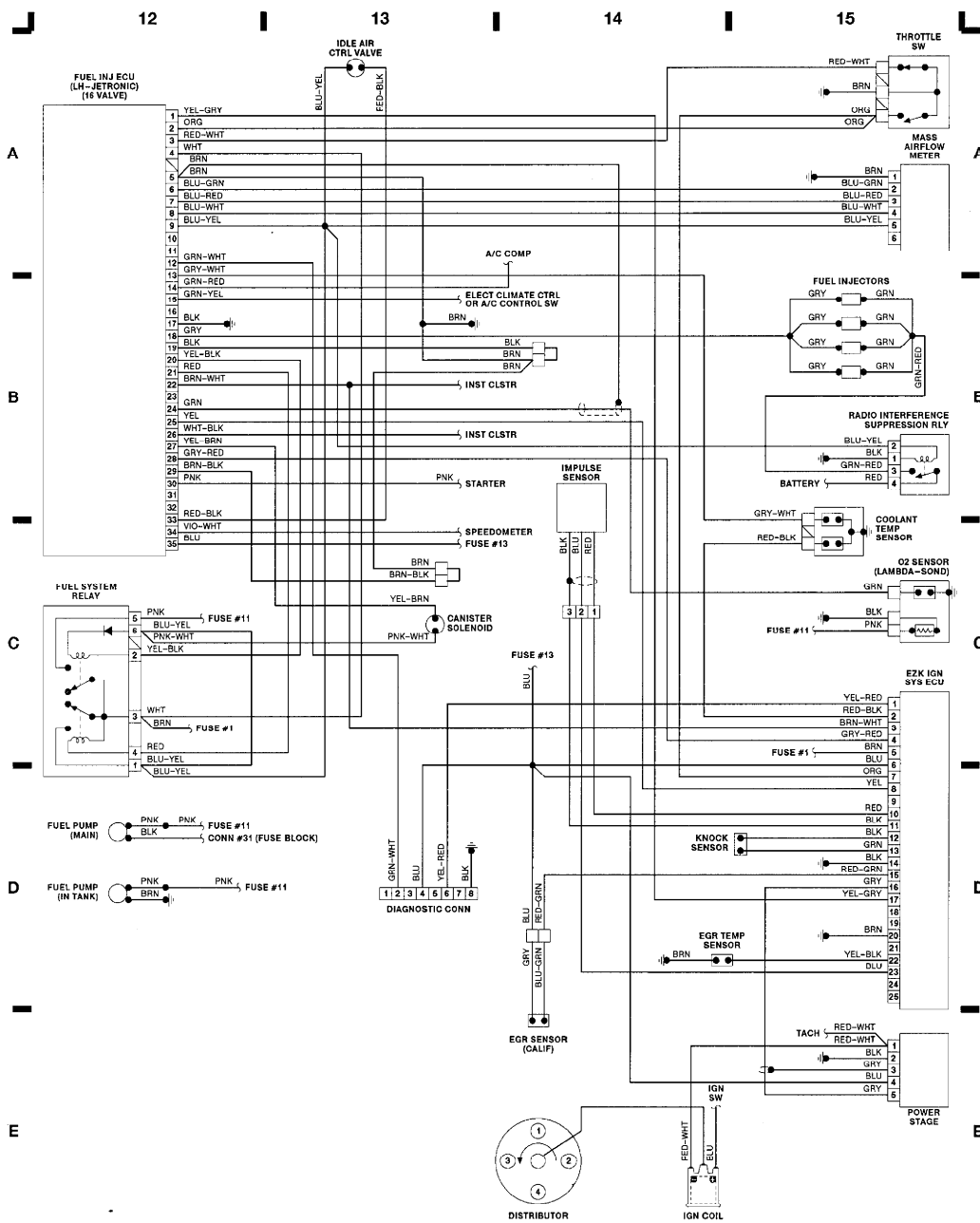
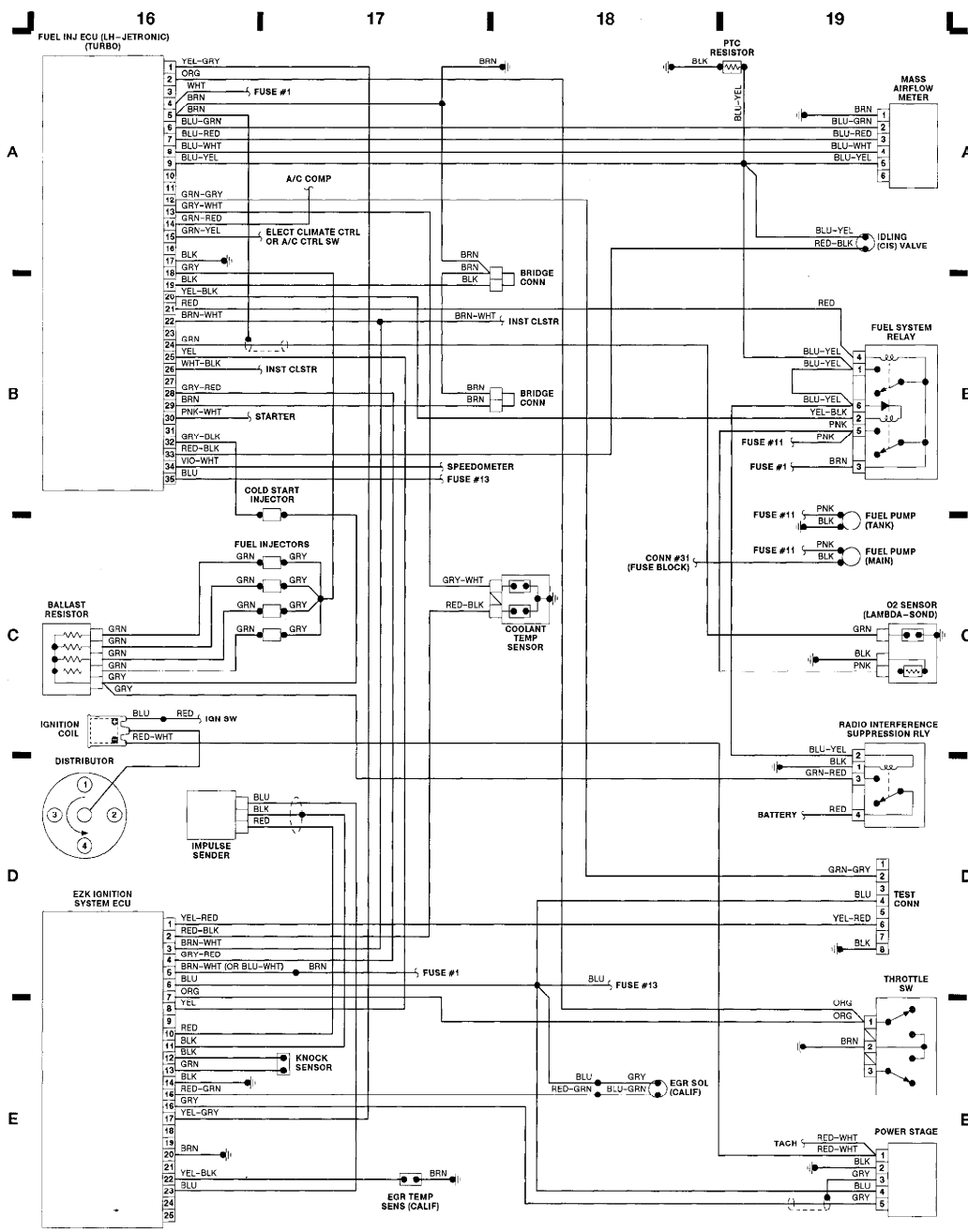
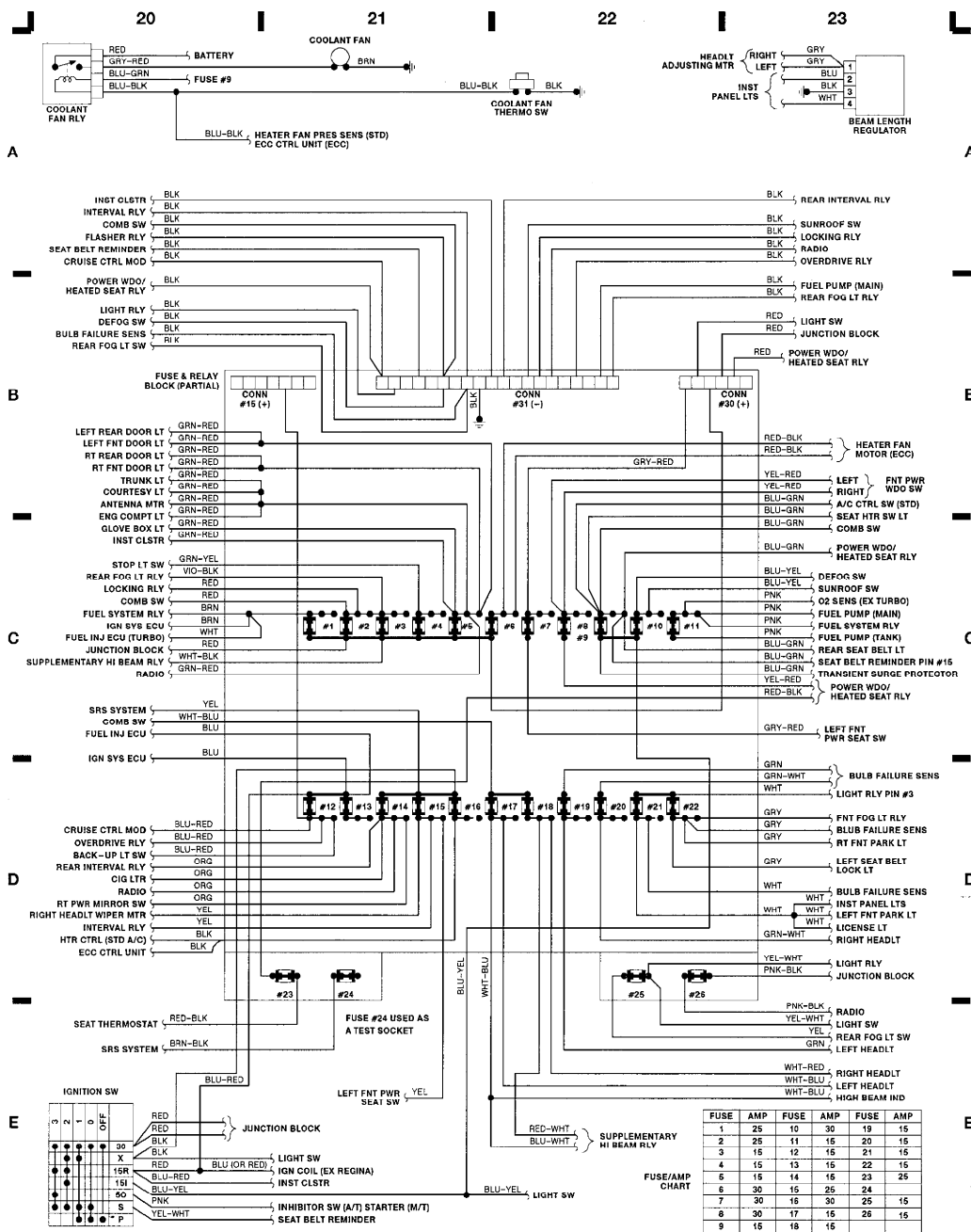

Fig. 4: Computer Eng Control (LH-Jetronic, 16 Valve) (Grids 12-15)



90D21934
 Fig. 5: Computer Eng Control (LH-Jetronic, Turbo) (Grids 16-19)



90E21935
 Fig. 6: Fuse/Relay Block (Partial) (Grids 20-23)

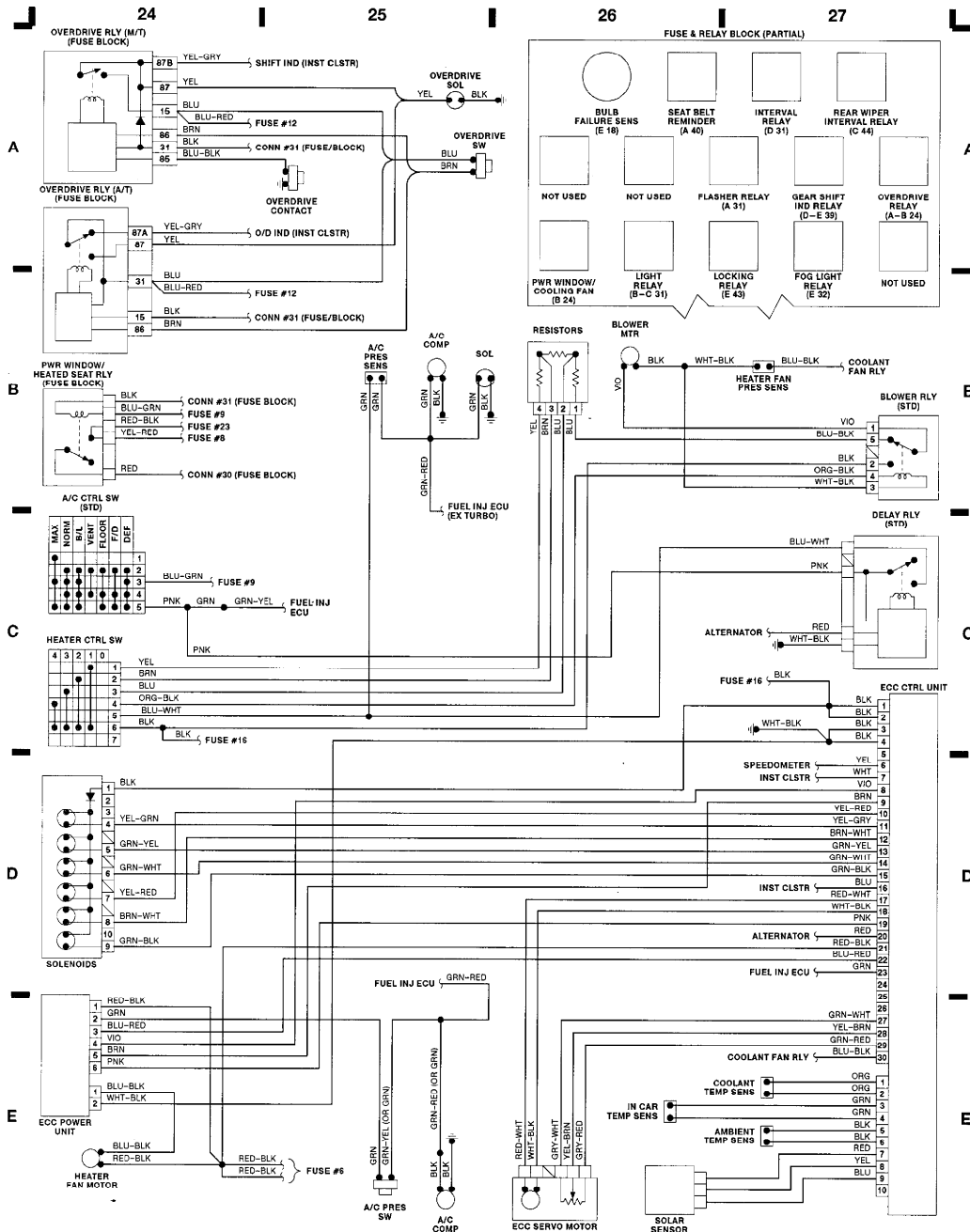

Fig. 7: Fuse Relay (Cont), A/C & Heater, O/D (Grids 24-27)

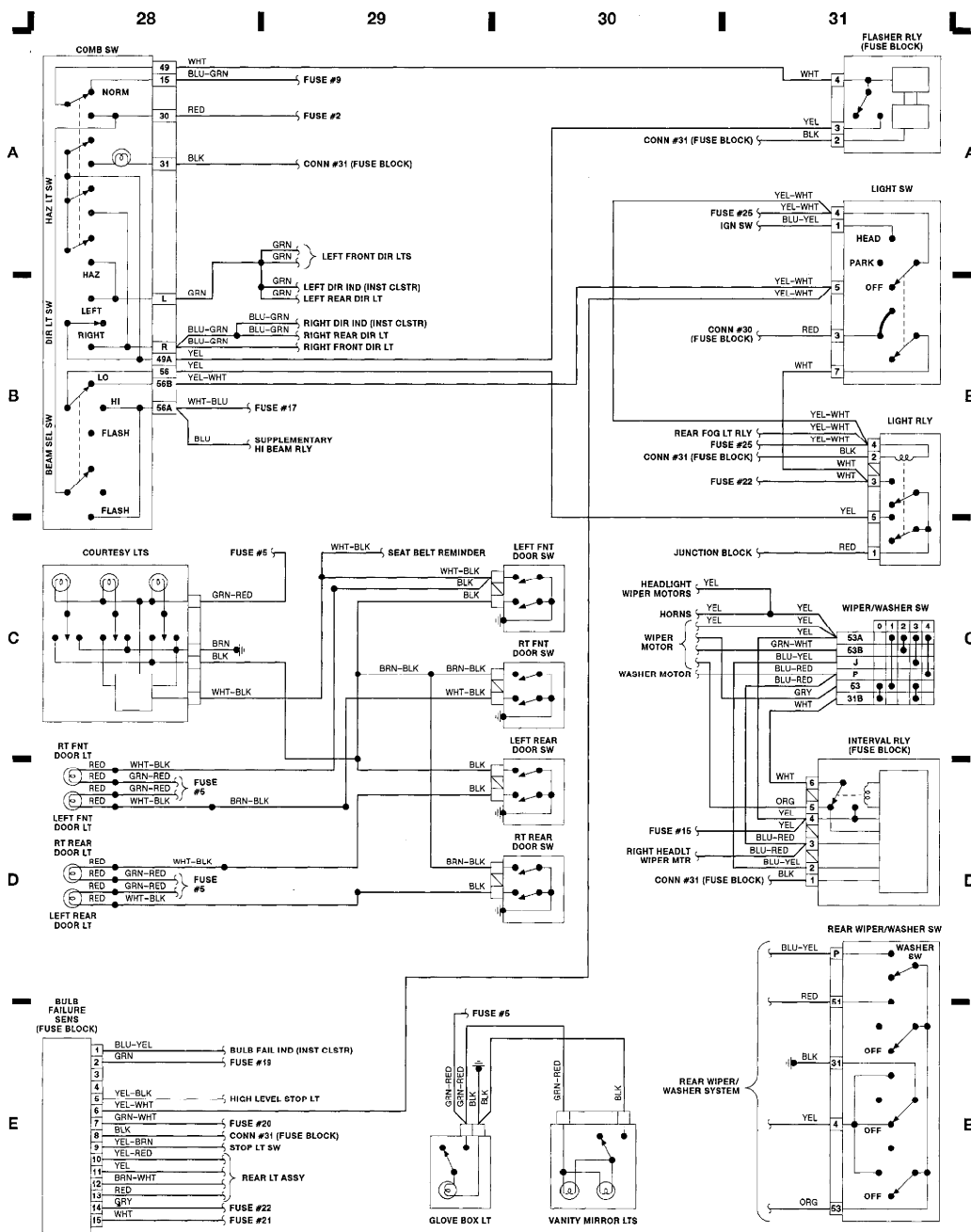

Fig. 8: Steering Column (Grids 28-31)

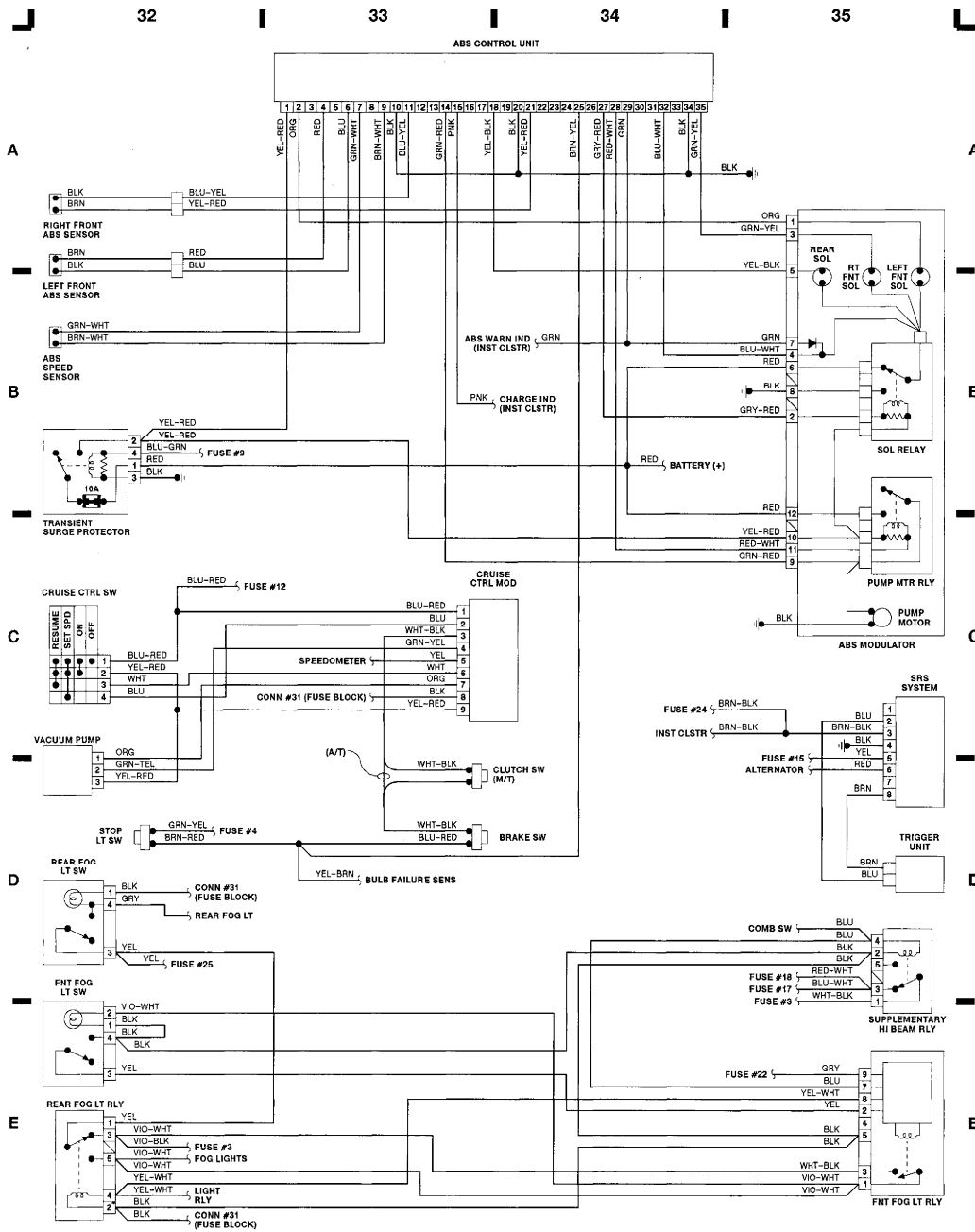

Fig. 9: ABS, SRS, Cruise Control, Fog Lights (Grids 32-35)

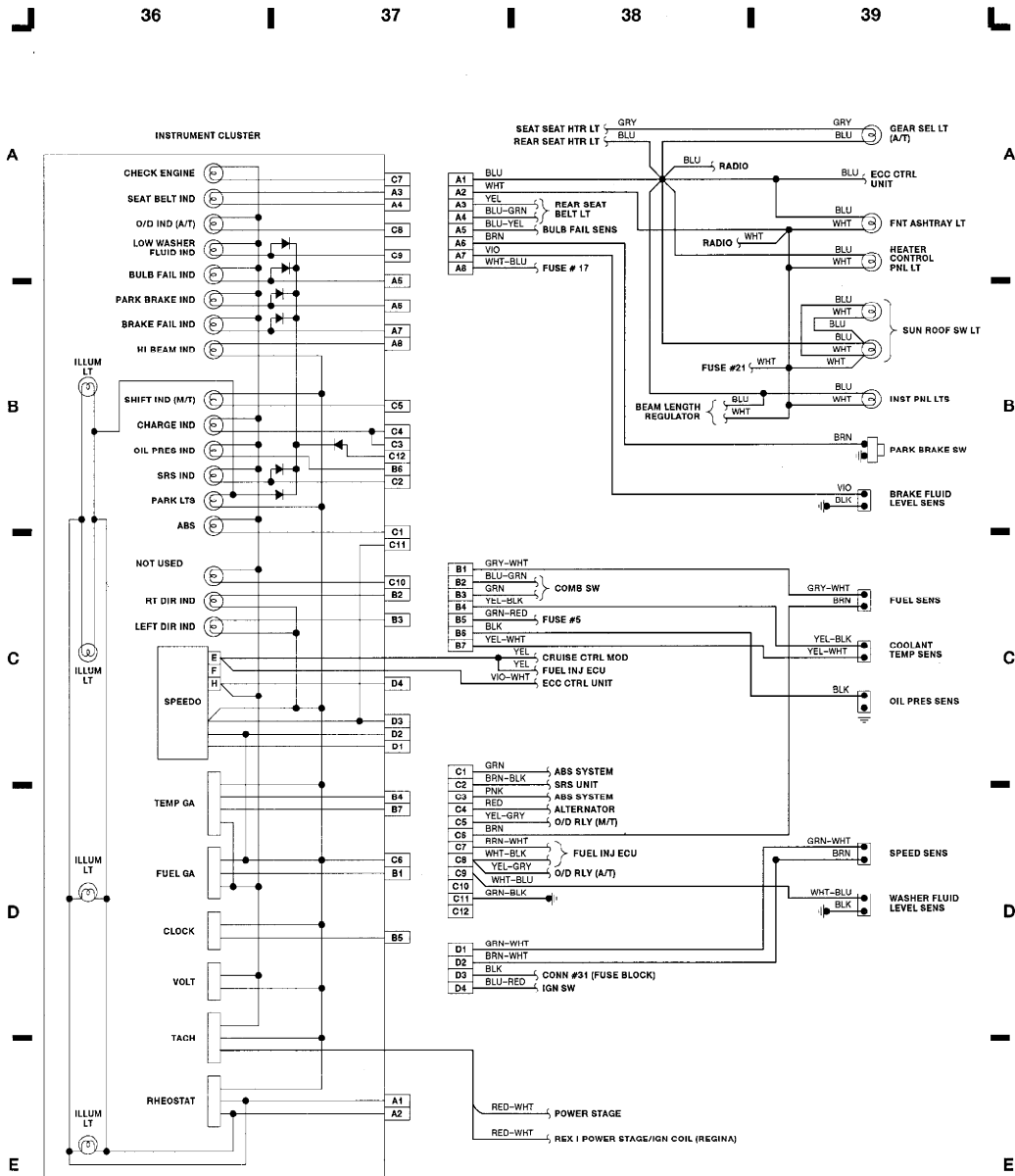

Fig. 10: Instrument Panel (Grids 36-39)

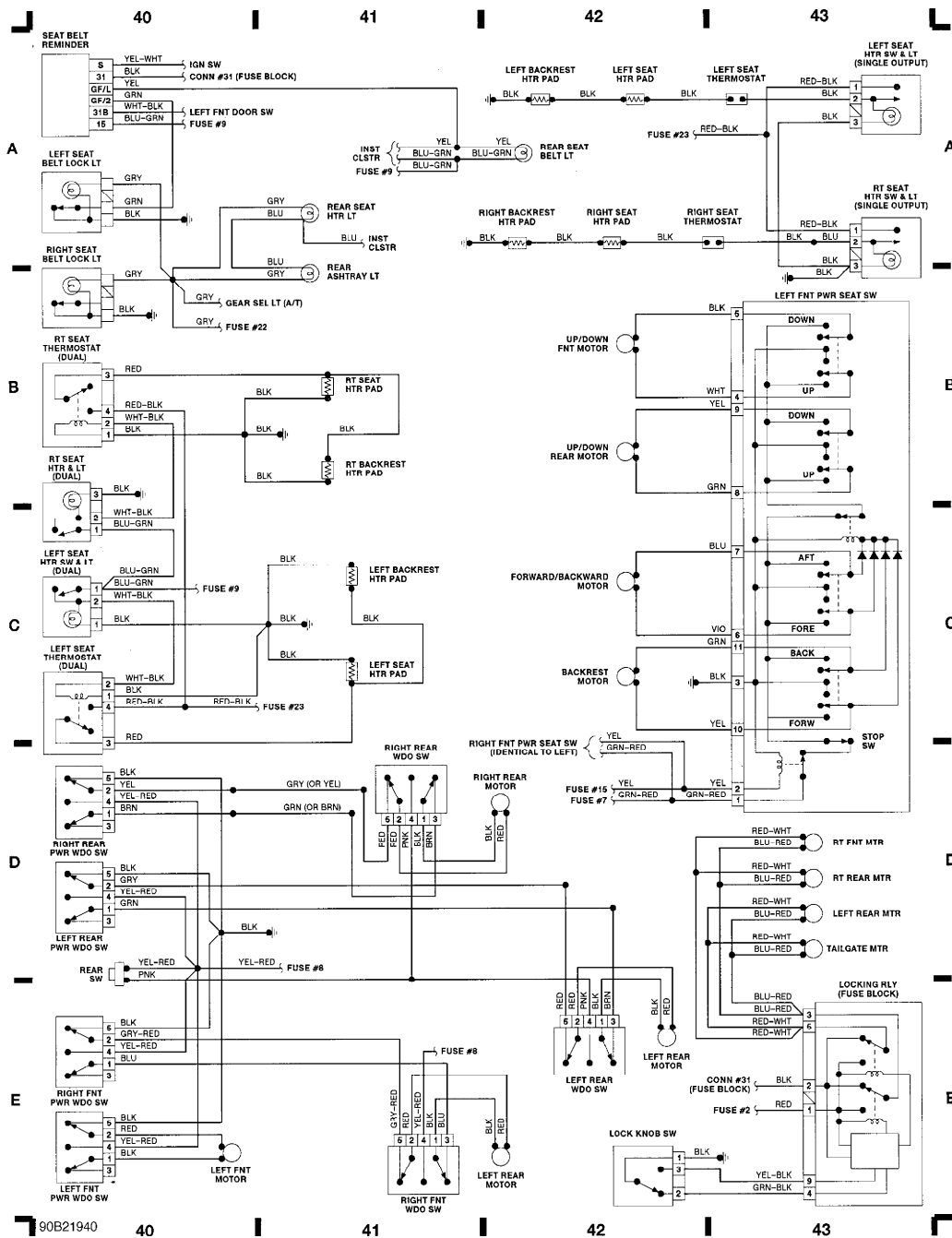
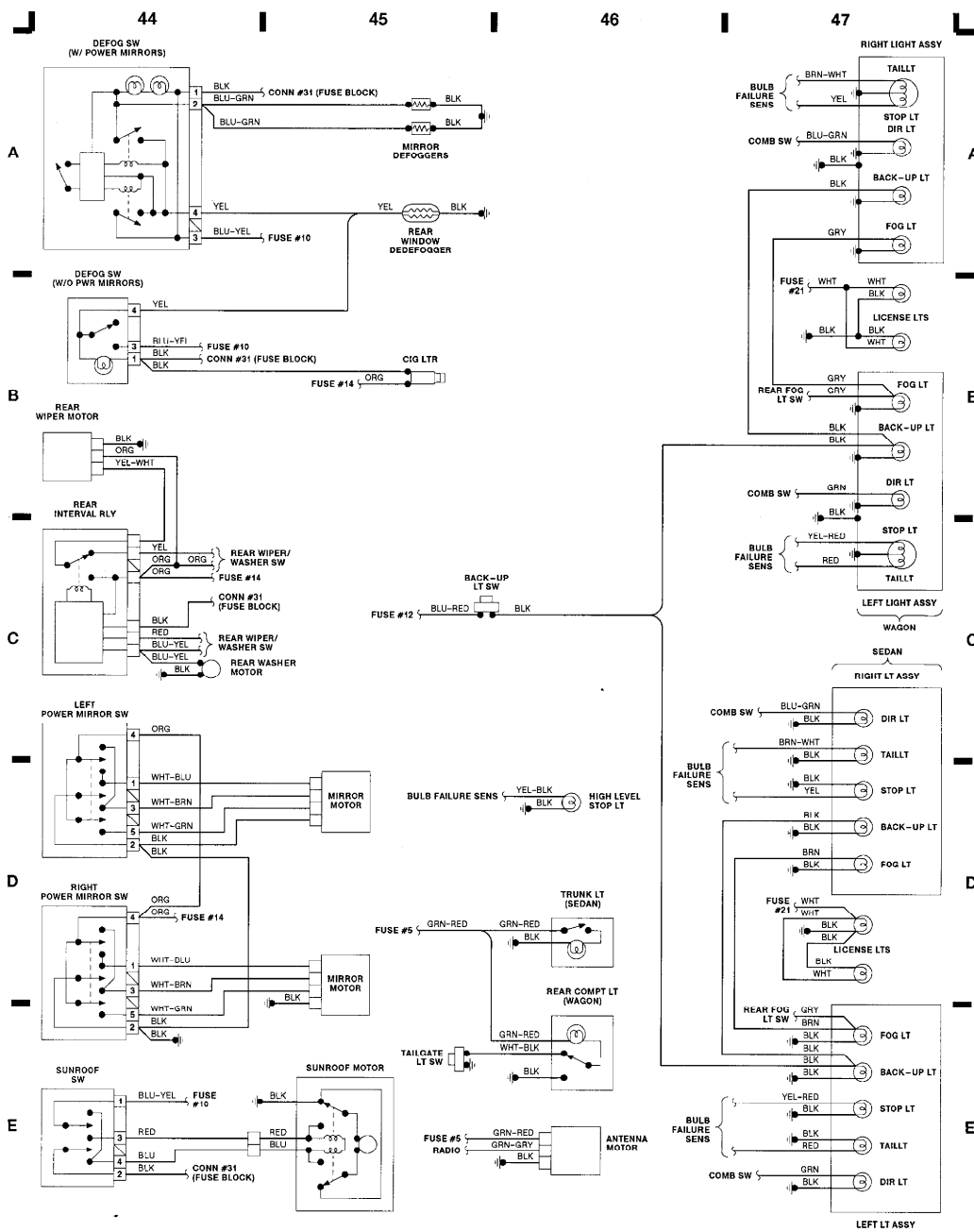

Fig. 11: Power Seat/Window Door (Grids 40-43)



90C21941 44 45 46 47
 Fig. 12: Power Mirror, Sunroof, Taillights (Grids 44-47)