

Canon

DIGITAL VIDEO CAMCORDER
Instruction Manual

English

CAMESCOPE NUMÉRIQUE
Manuel d'instruction

Français

VIDEOCÁMARA DIGITAL
Manual de Instrucciones

Español

XL2

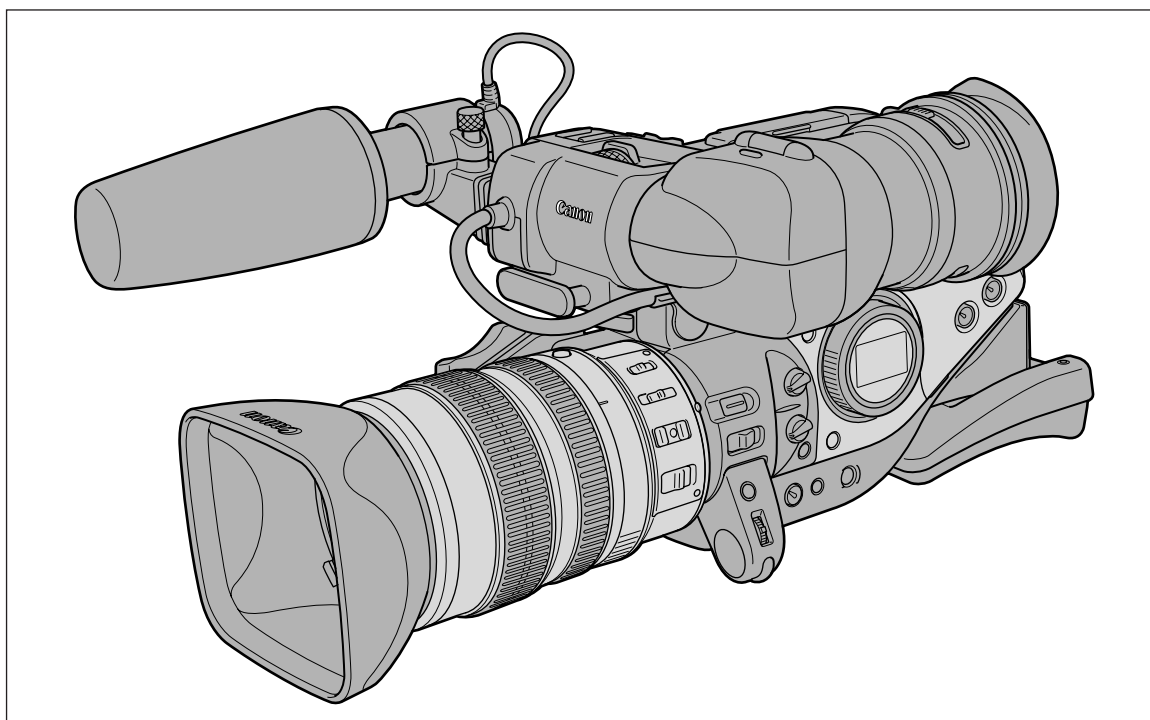

Mini **DV** Digital
Video
Cassette

A **NTSC**

Important Usage Instructions

WARNING:



TO REDUCE THE RISK OF FIRE OR ELECTRIC SHOCK, DO NOT EXPOSE THIS PRODUCT TO RAIN OR MOISTURE.

WARNING:



TO REDUCE THE RISK OF ELECTRIC SHOCK AND TO REDUCE ANNOYING INTERFERENCE, USE THE RECOMMENDED ACCESSORIES ONLY.

COPYRIGHT WARNING:

Unauthorized recording of copyrighted materials may infringe on the rights of copyright owners and be contrary to copyright laws.

Digital Video Camcorder, XL2A Systems.

This device complies with Part 15 of the FCC Rules. Operation is subject to the following two conditions: (1) This device may not cause harmful interference, and (2) this device must accept any interference received, including interference that may cause undesired operation.

Note: This equipment has been tested and found to comply with the limits for class B digital device, pursuant to Part 15 of the FCC Rules. These limits are designed to provide reasonable protection against harmful interference in a residential installation. This equipment generates, uses and can radiate radio frequency energy and, if not installed and use in accordance with the instructions, may cause harmful interference to radio communications. However, there is no guarantee that interference will not occur in a particular installation. If this equipment does cause harmful interference to radio or television reception, which can be determined by turning the equipment off and on, the user is encouraged to try to correct the interference by one or more of the following measures:

- Reorient or relocate the receiving antenna.
- Increase the separation between the equipment and receiver.
- Connect the equipment into an outlet on a circuit different from that to which the receiver is connected.
- Consult the dealer or an experienced radio/TV technician for help.

Use of shielded cable is required to comply with class B limits in Subpart B of Part 15 of FCC Rules.

Do not make any changes or modifications to the equipment unless otherwise specified in the manual.

If such changes or modifications should be made, you could be required to stop operation of the equipment.

Canon U.S.A. Inc.

One Canon Plaza, Lake Success, NY 11042, U.S.A.

Tel No. (516)328-5600

CAUTION:

TO PREVENT ELECTRIC SHOCK, MATCH WIDE BLADE OF PLUG TO WIDE SLOT, FULLY INSERT.

Important Warning



The lightning flash with arrowhead symbol, within an equilateral triangle, is intended to alert the user to the presence of uninsulated "dangerous voltage" within the product's enclosure, that may be of sufficient magnitude to constitute a risk of electric shock to persons.

CAUTION:

TO REDUCE THE RISK OF ELECTRIC SHOCK, DO NOT REMOVE COVER (OR BACK). NO USER-SERVICEABLE PARTS INSIDE. REFER SERVICING TO QUALIFIED SERVICE PERSONNEL.



The exclamation point, within an equilateral triangle, is intended to alert the user to the presence of important operating and maintenance (servicing) instructions in the literature accompanying the product.

IMPORTANT SAFETY INSTRUCTIONS

In these safety instructions the word “product” refers to the Canon Digital Video Camcorder XL2A and all its accessories.

1. Read Instructions — All the safety and operating instructions should be read before the product is operated.
2. Retain Instructions — The safety and operating instructions should be retained for future reference.
3. Heed Warnings — All warnings on the product and in the operating instructions should be adhered to.
4. Follow Instructions — All operating and maintenance instructions should be followed.
5. Cleaning — Unplug this product from the wall outlet before cleaning. Do not use liquid or aerosol cleaners. The product should be cleaned only as recommended in this manual.
6. Accessories — Do not use accessories not recommended in this manual as they may be hazardous.
7. Avoid magnetic or electric fields — Do not use the camera close to TV transmitters, portable communication devices or other sources of electric or magnetic radiation. They may cause picture interference, or permanently damage the camera.
8. Water and Moisture — Hazard of electric shock — Do not use this product near water or in rainy/moist situations.
9. Placing or Moving — Do not place on an unstable cart, stand, tripod, bracket or table. The product may fall, causing serious injury to a child or adult, and serious damage to the product.
A product and cart combination should be moved with care. Quick stops, excessive force, and uneven surfaces may cause the product and cart combination to overturn.
10. Power Sources — The CA-920 Compact Power Adapter should be operated only from the type of power source indicated on the marking label. If you are not sure of the type of power supply to your home, consult your product dealer or local power company. Regarding other power sources such as battery power, refer to instructions in this manual.
11. Polarization — The CA-920 Compact Power Adapter is equipped with a polarized 2-prong plug (a plug having one blade wider than the other). The 2-prong polarized plug will fit into the power outlet only one way. This is a safety feature. If you are unable to insert the plug fully into the outlet, try reversing the plug. If the plug still fails to fit, contact your electrician to replace your obsolete outlet. Do not defeat the safety purpose of the polarized plug.



12. Power Cord Protection — Power cords should be routed so that they are not likely to be walked on or pinched by items placed upon or against them. Pay particular attention to plugs and the point from which the cords exit the product.
13. Outdoor Antenna Grounding — If an outside antenna is connected to the product, be sure the antenna is grounded so as to provide some protection against voltage surges and built-up static charges. Section 810 of the National Electrical Code, ANSI / NFPA No. 70—1984, provides information with respect to proper grounding of the mast and supporting structure, grounding of the lead-in wire to an antenna discharge unit, size of grounding conductors, location of antenna discharge unit, connection to grounding electrodes, and requirements for the grounding electrode. See figure 1.

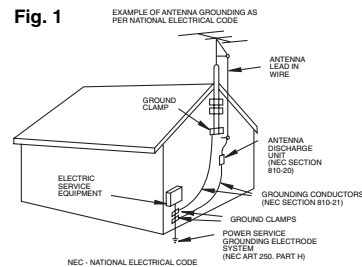

14. Lightning — For added protection of this product during a lightning storm, or when it is left unattended and unused for long periods of time, disconnect it from the wall outlet and disconnect the antenna. This will prevent damage to the product due to lightning and power-line surges.
15. Power Lines — An outside antenna system should not be located in the vicinity of overhead power lines or other electric light or power circuits, or where it can fall into such power lines or circuits. When installing an outside antenna system, extreme care should be taken to keep from touching such power lines or circuits as contact with them might be fatal.
16. Overloading — Do not overload wall outlets and extension cords as this can result in a risk of fire or electric shock.
17. Objects and Liquid Entry — Never push objects of any kind into this product through openings as they may touch dangerous voltage points or short out parts that could result in a fire or electric shock. Be careful not to spill liquid of any kind onto the product.
18. Servicing — Do not attempt to service this product yourself as opening or removing covers may expose you to dangerous voltage or other hazards. Refer all servicing to qualified service personnel.

19. Damage Requiring Service — Disconnect this product from the wall outlet and all power sources including battery, and refer servicing to qualified service personnel under the following conditions:
- a. When the power-supply cord or plug is damaged.
 - b. If any liquid has been spilled onto, or objects have fallen into, the product.
 - c. If the product has been exposed to rain or water.
 - d. If the product does not operate normally even if you follow the operating instructions. Adjust only those controls that are covered by the operation instructions. Improper adjustment of other controls may result in damage and will often require extensive work by a qualified technician to restore the product to its normal operation.
 - e. If the product has been dropped or the cabinet has been damaged.
 - f. When the product exhibits a distinct change in performance. This indicates a need for service.
20. Replacement Parts — When replacement parts are required, be sure the service technician has used replacement parts that are specified by Canon or that have the same characteristics as the original part. Unauthorized substitutions may result in fire, electric shock or other hazards.
21. Safety Check — Upon completion of any service or repairs to this product, ask the service technician to perform safety checks to determine that the product is in safe operating order.

When replacement of power supply is required, please return it to the responsible nearest Canon Service Center and please replace it with the same type number CA-920.



The Adapter can be used with a power supply between 100 and 240 V AC. Contact your Canon dealer for information about plug adapter for overseas use.

Using this Manual

Thank you for purchasing the Canon XL2. Please read this manual carefully before you use the camcorder and retain it for future reference.

E

Symbols and References Used in This Manual

-  : Precautions related to the camcorder operation.
-  : Additional topics that complement the basic operating procedures.
-  : Reference page number.
- Capital letters are used to refer to buttons on the camcorder or the wireless controller.
- [] are used to refer to menu items displayed on the screen.
- The 20× L IS Zoom Lens XL 5.4-108 mm supplied with the Lens Kit is referred to as “20× L IS Lens”.
- The illustrations show the camcorder attached with the 20× L IS Lens.

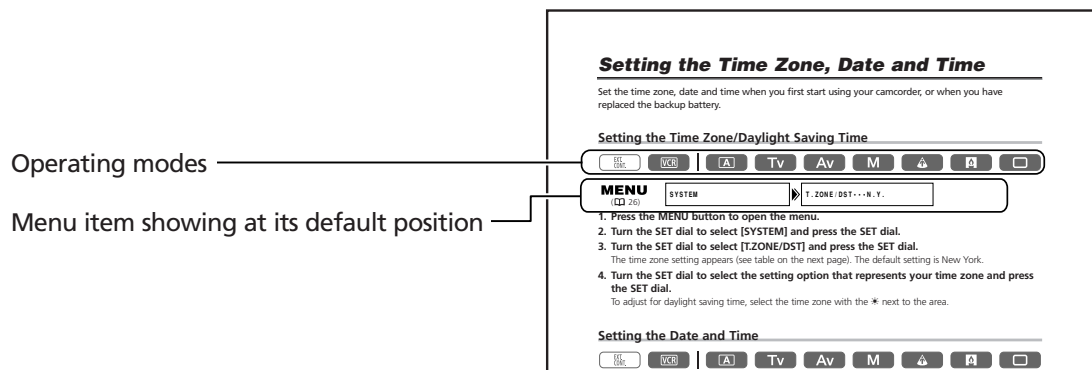



- Available functions depend on the operating mode and are indicated as follows:

 : Function can be used in this mode.

 : Function cannot be used in this mode.

Trademark Acknowledgements

- Canon is a registered trademarks of Canon Inc.
- Mini  is a trademark.
-  is a trademark.
- Windows® is either a registered trademark or trademark of Microsoft Corporation in the United States and/or other countries.
- Other names and products not mentioned above may be registered trademarks or trademarks of their respective companies.

Contents

Introduction

Important Usage Instructions	2
Important Safety Instructions	3
Using this Manual	5
Checking Supplied Accessories	8
Components Guide	9

Preparation

Preparing the Power Supply	13
Installing the Backup Battery	16
Preparing the Camcorder	17
Preparing the Lens.....	22
Using the Wireless Controller	24
Loading/Unloading a Cassette	25
Menus and Settings	26
Setting the Time Zone, Date and Time	30

Recording

Recording	32
End Search	37
Zooming	38
Adjusting the Focus	40
Using the ND Filter (Lenses with Built-in ND Filter)	43
Selecting the Frame Rate	44
Recording in 16:9 Mode	46
Setting the Time Code.....	47
Setting the User Bit	49
Audio Recording	50
Image Stabilizer (Lenses Equipped with Image Stabilizer).....	54
Using the Programmed AE Modes	55
Recording in the Shutter-Priority (Tv) Mode	58
Recording in the Aperture-Priority (Av) Mode	59
Recording in the Manual Mode	60
Adjusting the Exposure	61
Using AE Shift	62
Adjusting the Gain	63
Setting the White Balance	64
Using the Zebra Pattern	66
Using the Skin Detail Function	67
Using the Custom Preset	68
Using Clear Scan for Recording Computer Screens.....	73
Using the Custom Keys	74
Recording Color Bars/Audio Reference Signal.....	77
Recording with the Interval Timer	79
Recording with the Self-Timer	81
Using the DV Control	82
Other Camcorder Functions/Settings	83

Playback

Playing Back a Tape	85
Playing Back on a TV Screen	87
Audio Output.....	89
Returning to a Pre-Marked Position	90
Index Search	91
Date Search	92
Displaying the Data Code	93
Changing the Remote Sensor Mode	95

Editing



Recording to a VCR or Digital Video Device	96
Recording from Analog Video Devices (VCR, TV or Camcorder)	97
Recording from Digital Video Devices (DV Dubbing)	98
Converting Analog Signals into Digital Signals (Analog-Digital Converter)	99
Connecting to the Computer Using a DV (IEEE1394) Cable	101

Additional Information

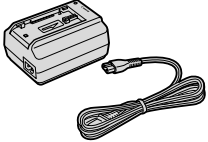
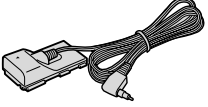
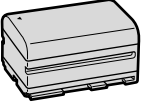

Settings Retained at Power Off or STANDBY Mode	102
Screen Displays.....	104
List of Messages	107
Maintenance/Others	108
Troubleshooting.....	113
System Diagram	115
Optional Accessories	116
Specifications	119
Index	121
Audio Block Diagram	122

Checking Supplied Accessories

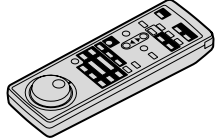
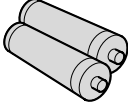
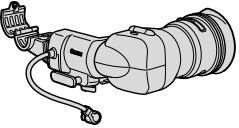
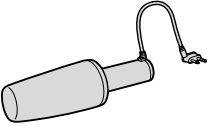
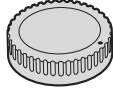
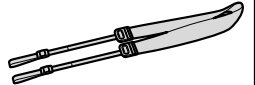
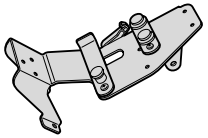
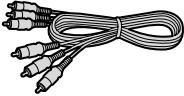
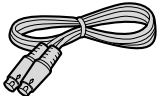
Body Kit

<p>CA-920 Compact Power Adapter</p> 	<p>DC-920 DC Coupler</p> 	<p>BP-930 Battery Pack</p> 	<p>Lithium Button Battery CR2025</p> 	<p>WL-D4000 Wireless Controller</p> 
<p>Two AAA (R03) Batteries</p> 	<p>Color Viewfinder</p> 	<p>Microphone Unit</p> 	<p>Camcorder Dust Cap</p> 	<p>SS-1000 Shoulder Strap</p> 
<p>Adapter Holder</p> 	<p>STV-150 Stereo Video Cable</p> 	<p>S-150 S-video Cable</p> 		

Additional Accessories Supplied with the Lens Kit

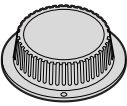
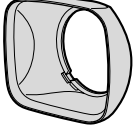
<p>20x L IS Zoom Lens XL 5.4-108 mm (with soft case)</p> 	<p>Lens Cap</p> 	<p>Lens Dust Cap</p> 	<p>Lens Hood</p> 
--	---	--	---

The serial number of this product can be found at the battery attachment unit of the camcorder. Write down the number and other information here and retain this book as a permanent record of your purchase to aid identification in case of theft.

Date of Purchase:
 Purchased From:
 Dealer Address:
 Dealer Phone No.:

Model Name: XL2
 Serial No.:

Components Guide

XL2

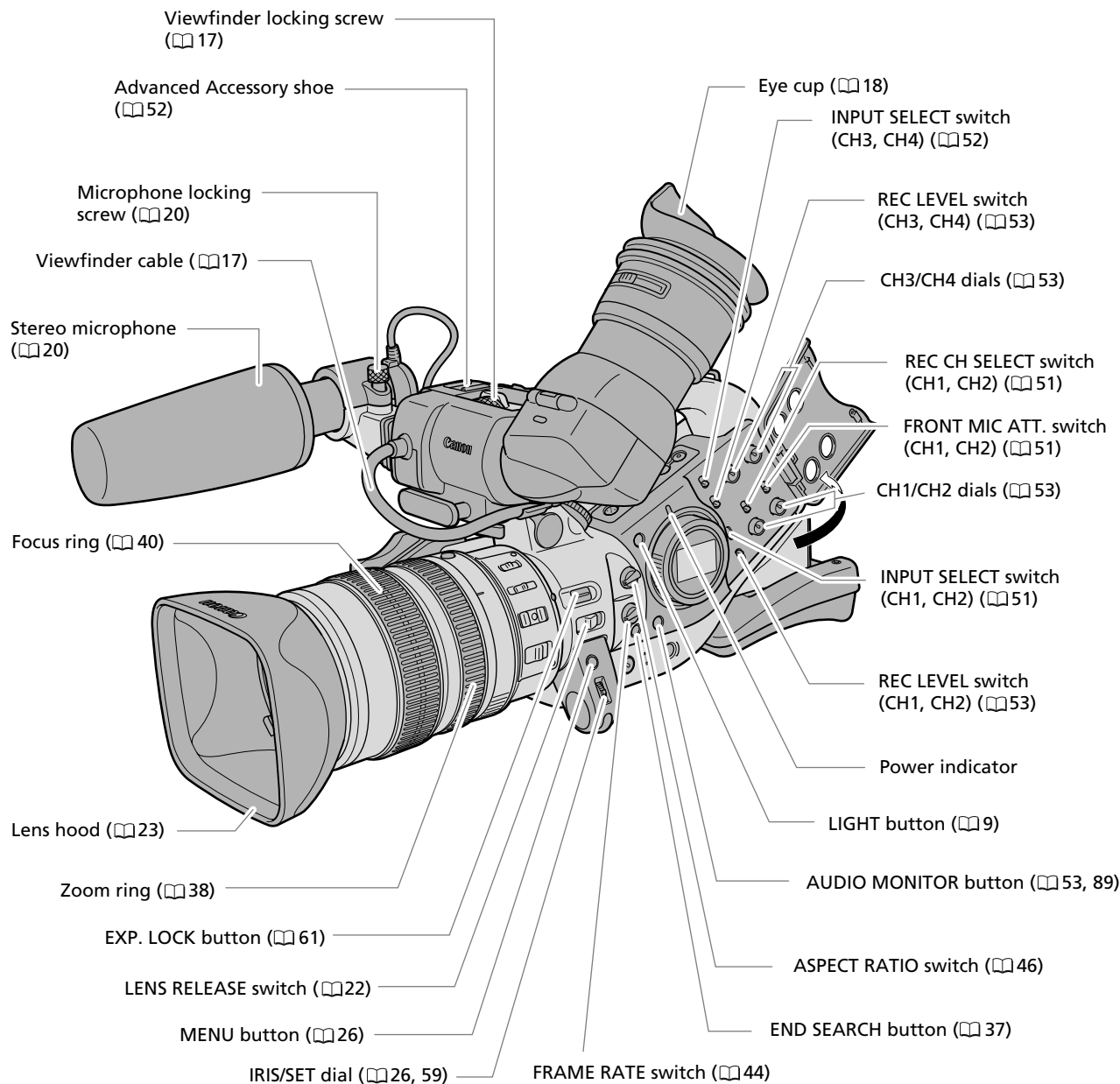

E

Introduction

LIGHT Button

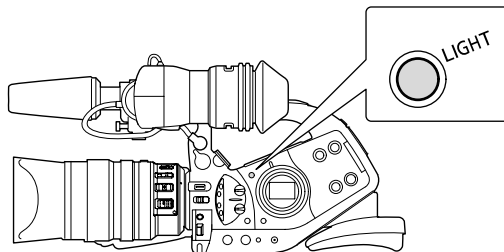

Press the LIGHT button to illuminate the side panel for approximately 10 seconds. If you press and hold the button for at least 3 seconds, the panel remains illuminated until you press the button once more to turn the backlight off.

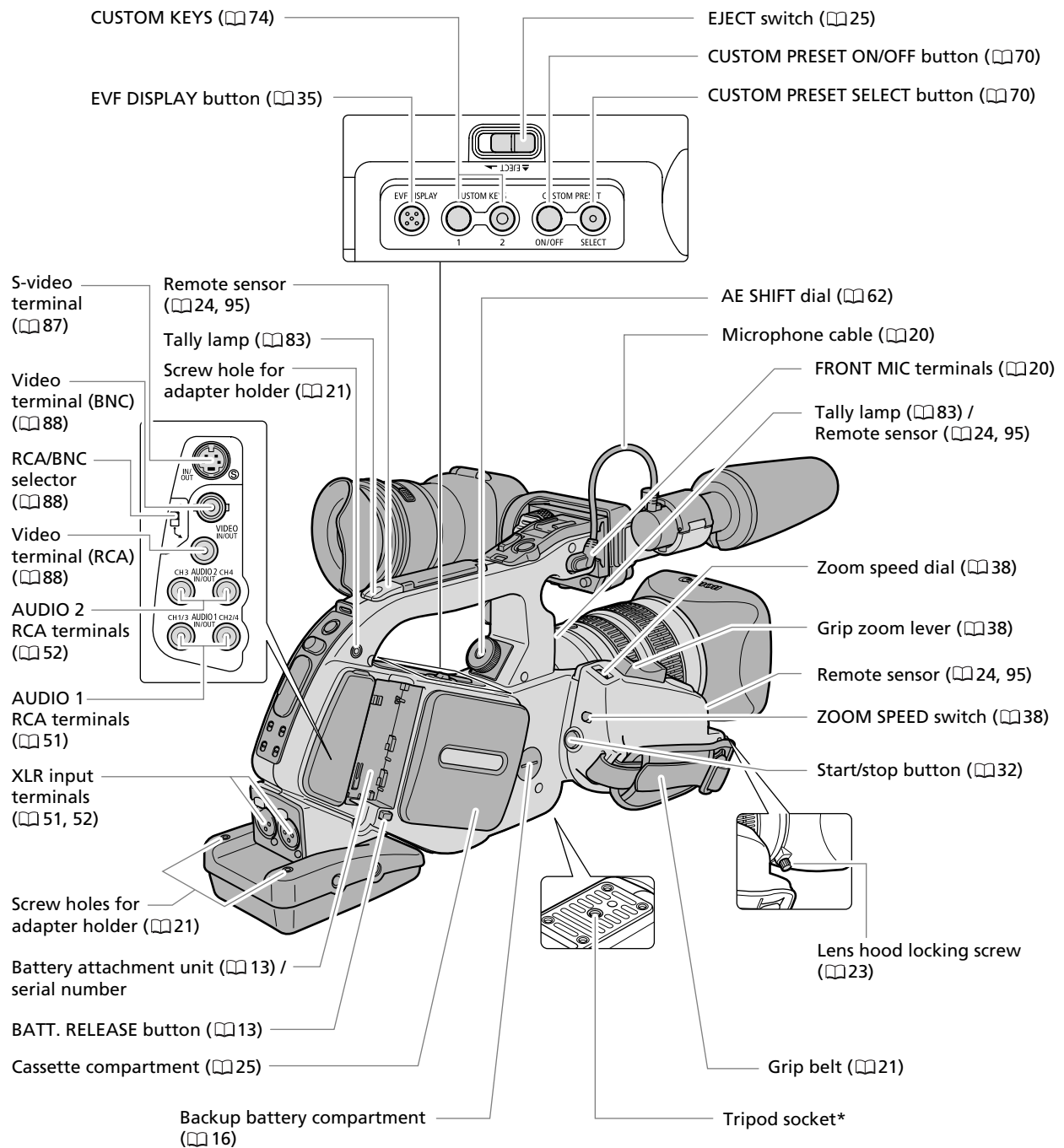





* Do not use tripods with fastening screws longer than 0.2 inch (5.5 mm) as it may damage the camcorder.

About the Terminal

 (LANC) stands for Local Application Control Bus System. The  terminal allows you to connect and control connected devices.

- Connect only devices with the  mark to the  terminal.
- Operation cannot be guaranteed for connections with devices not bearing the  mark.
- Some buttons of connected devices may not operate or may operate differently than the buttons on the camcorder.

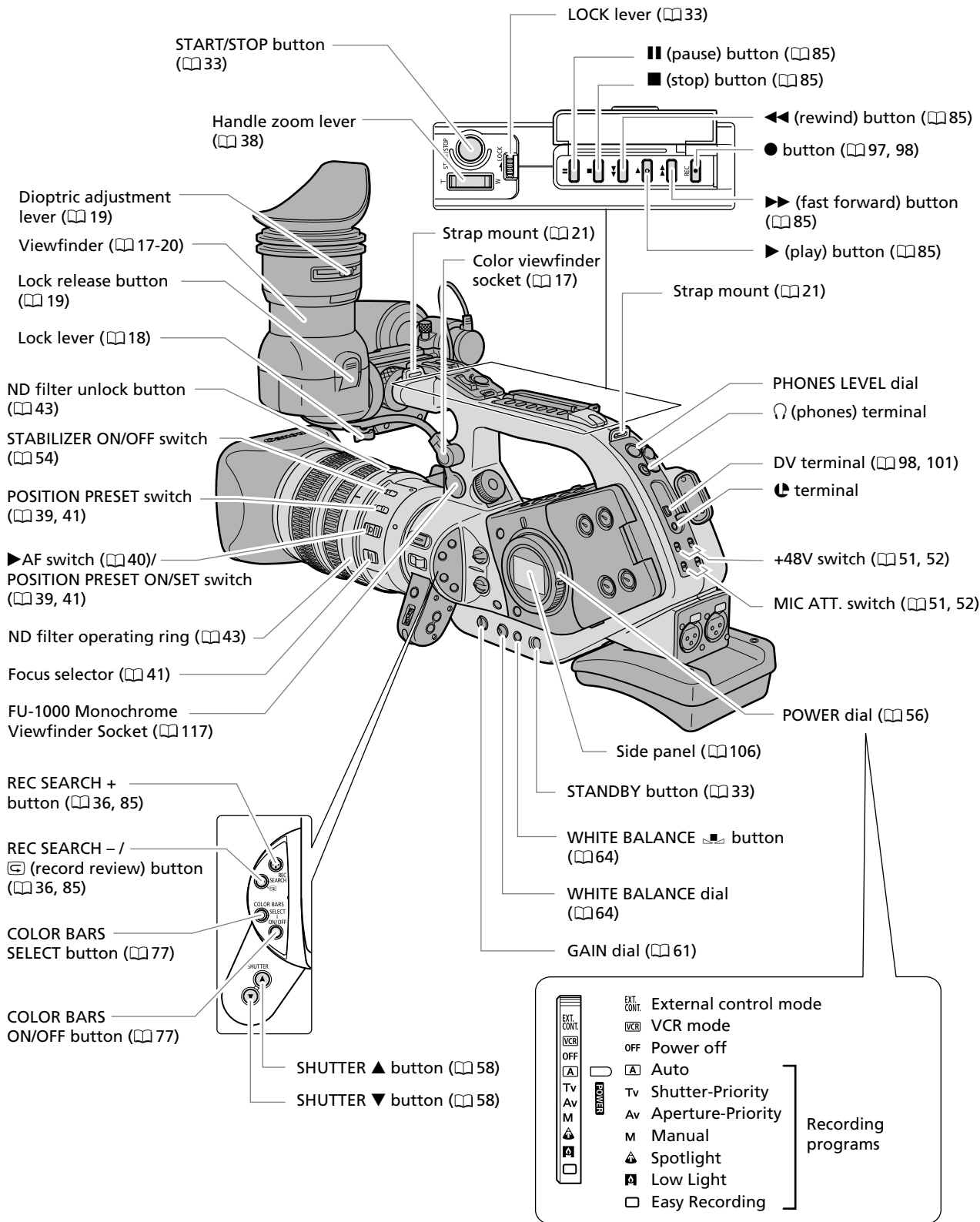

EXT. CONT.	External control mode	Recording programs
VCR	VCR mode	
OFF	Power off	
A	Auto	
Tv	Shutter-Priority	
Av	Aperture-Priority	
M	Manual	
▲	Spotlight	
■	Low Light	
□	Easy Recording	

WL-D4000 Wireless Controller

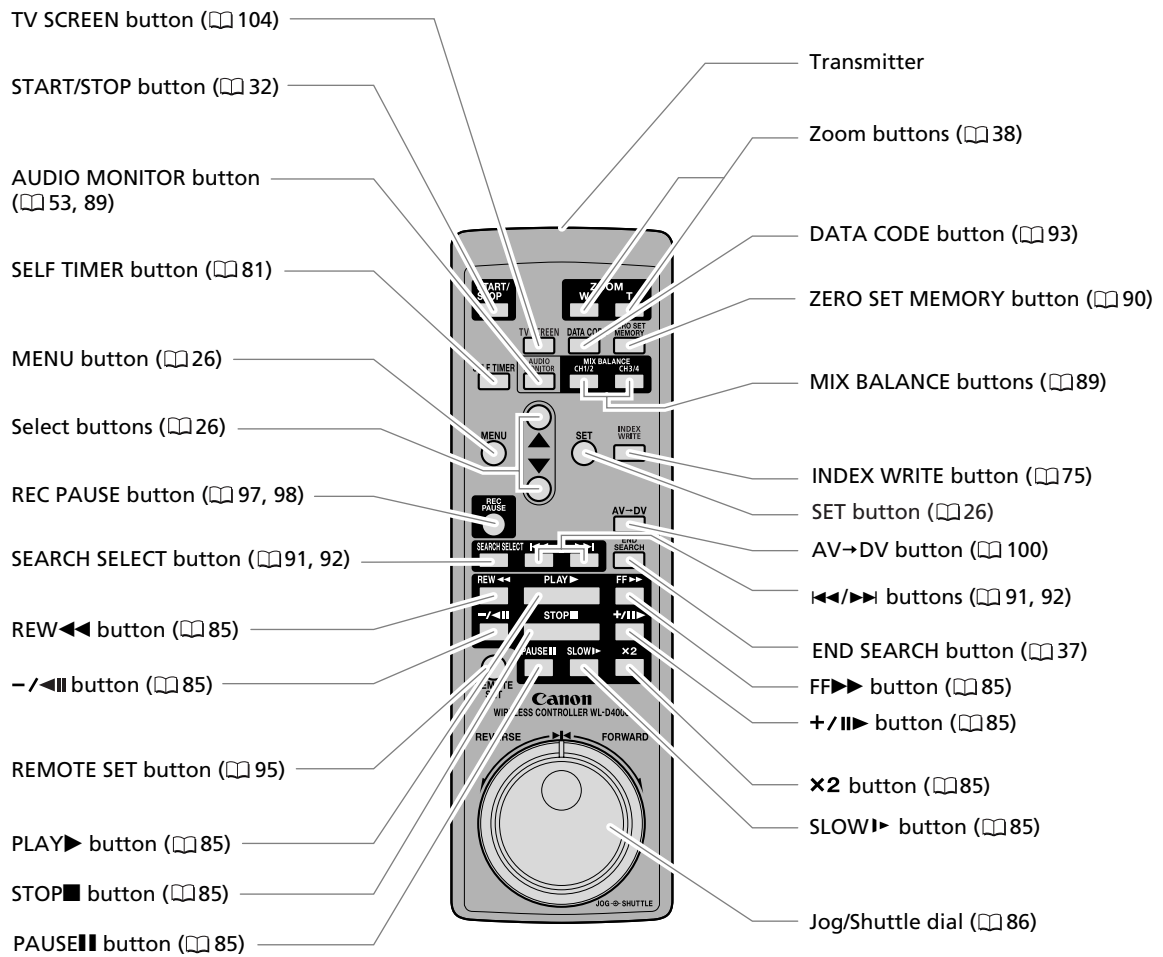

Preparing the Power Supply

Charging the Battery Pack

Disconnect the DC coupler from the power adapter before charging. Remove the terminal cover of the battery pack.

1. **Connect the power cord to the adapter.**
2. **Plug the power cord into a power outlet.**
3. **Attach the battery pack to the adapter.**
 - Press lightly and slide it in the direction of the arrow until it clicks.
 - The CHARGE indicator starts flashing. It glows steadily when charging is complete.
4. **When charging is complete, remove the battery pack from the adapter.**
5. **Unplug the power cord from the power outlet and disconnect it from the adapter.**

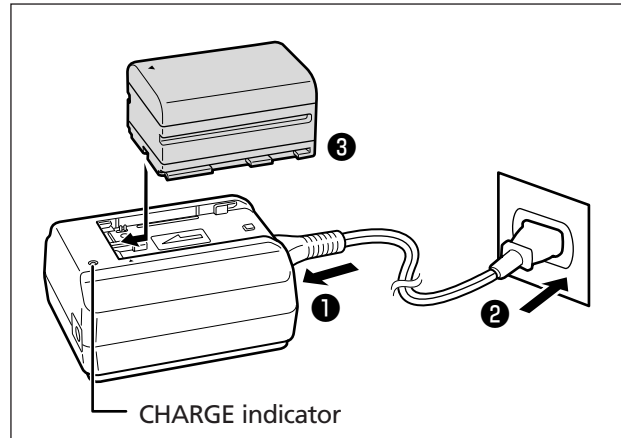

Attaching the Battery Pack

1. **Turn the POWER dial to OFF.**
2. **Attach the battery pack to the camcorder.**

Press lightly and slide it in the direction of the arrow until it clicks.
3. **Remove the battery pack after use.**

Press the BATT. RELEASE button to remove the battery.

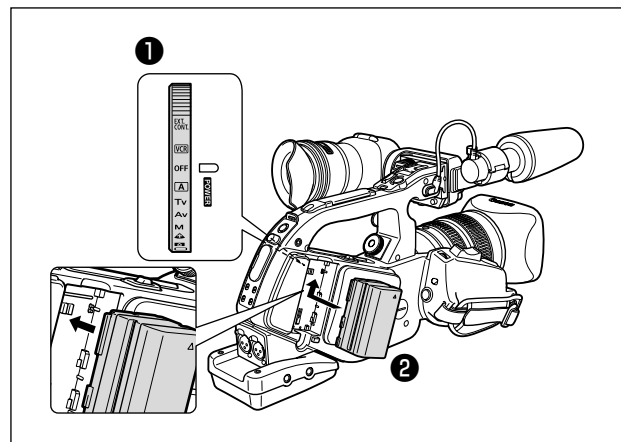

Using a Household Power Source

- 1. Turn the POWER dial to OFF.**
- 2. Attach the DC coupler to the camcorder.**
Press lightly and slide it in the direction of the arrow until it clicks.
- 3. Connect the power cord to the power adapter.**
- 4. Plug the power cord into a power outlet.**
- 5. Connect the DC coupler to the adapter.**
- 6. Detach the DC coupler after use.**
Press the BATT. RELEASE button to detach the DC coupler.

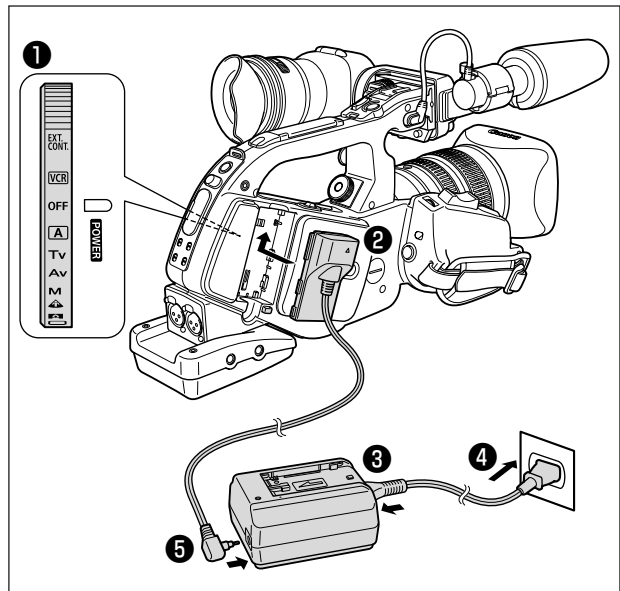

- Disconnect the DC coupler from the power adapter when charging a battery pack.
- Turn off the camcorder before connecting or disconnecting the power adapter.
- If the adapter is used close to a TV, it may cause picture interference. Move the adapter away from the TV or the antenna cable.
- Do not connect any products that are not expressly recommended to the power adapter.



- When the power adapter or battery pack is defective, the CHARGE indicator turns off, and charging stops.
- The CHARGE indicator informs you about the charge status.
 - 0-50%: Flashes once every second
 - 50%-75%: Flashes twice every second
 - More than 75%: Flashes 3 times every second
 - 100%: Glows steadily

○ Charging, Recording and Playback Times

Below times are approximate and vary according to the charging, recording or playback conditions.

Battery Pack			BP-930	BP-945
Charging Time with the CA-920			145 min.	220 min.
With 20× L IS Lens	Maximum Recording Time	With supplied color viewfinder	155 min.	230 min.
		With optional FU-1000 Monochrome Viewfinder	120 min.	185 min.
	Typical Recording Time*	With supplied color viewfinder	90 min.	135 min.
		With optional FU-1000 Monochrome Viewfinder	65 min.	100 min.
With 16× Manual Zoom Lens	Maximum Recording Time	With supplied color viewfinder	185 min.	280 min.
		With optional FU-1000 Monochrome Viewfinder	135 min.	205 min.
	Typical Recording Time*	With supplied color viewfinder	105 min.	160 min.
		With optional FU-1000 Monochrome Viewfinder	75 min.	115 min.
Playback Time			235 min.	360 min.

* Approximate times for recording with repeated operations such as start/stop, zooming, power on/off. Actual time may be shorter.

- We recommend charging the battery pack in temperatures between 50 °F and 86 °F (10 °C and 30 °C). Outside the temperature range of 32 °F to 104 °F (0 °C to 40 °C), the CHARGE indicator turns off, and charging stops.
- A lithium ion battery pack can be charged at any charge state. Unlike conventional battery packs, you do not need to completely use or discharge it before charging.
- We recommend that you prepare battery packs 2 to 3 times longer than you think you might need.
- To conserve battery power, turn off the camcorder instead of leaving it in record pause mode.

Installing the Backup Battery

The backup battery (lithium button battery CR2025) allows the camcorder to retain date, time (📅 30) and other camcorder settings while the power source is disconnected. Connect a power source to the camcorder when replacing the backup battery to retain the settings.

1. Open the backup battery cover.

Screw the cover to the left (use, for example, a coin).

2. Insert the backup battery with the + side facing outward.

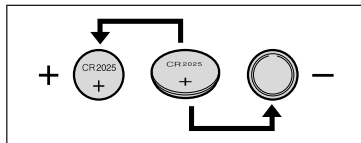

3. Close the cover.

Align the mark on the cover with the lower mark on the camcorder and screw the cover to the right until it clicks.

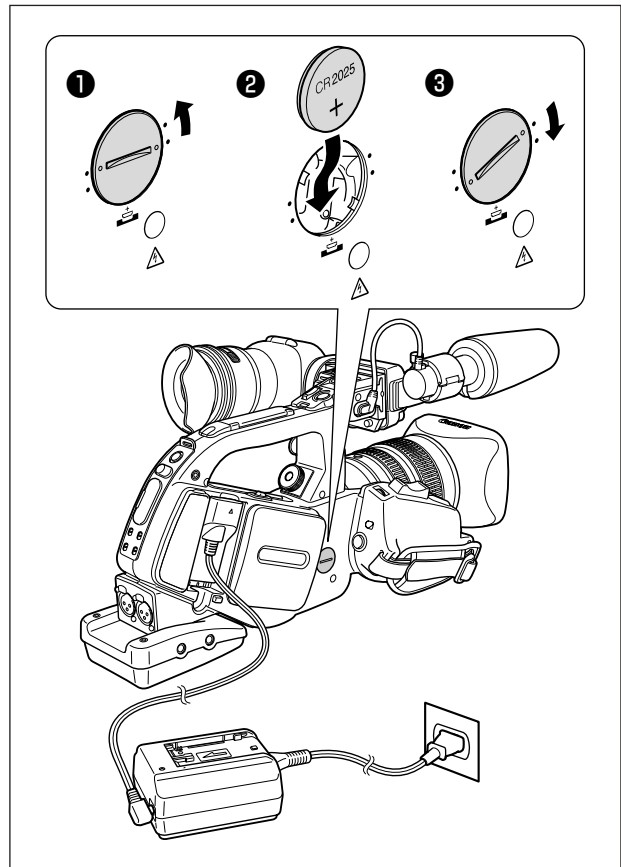

WARNING!

- The battery used in this device may present a fire or chemical burn hazard if mistreated. Do not recharge, disassemble, heat above 212 °F (100 °C) or incinerate the battery.
- Replace the battery with a CR2025 made by Panasonic, Hitachi Maxell, Sony, Sanyo, or with Duracell DL2025. Use of other batteries may present a risk of fire or explosion.



- Do not pick up the battery using tweezers or other metal tools as this will cause a short circuit.
- Wipe the battery with a clean dry cloth to ensure proper contact.
- Keep the battery out of reach of children. If it is swallowed, seek medical assistance immediately. The battery case may break, and the battery fluids may damage stomach and intestines.
- Do not disassemble, heat or immerse the battery in water to avoid the risk of explosion.



The backup battery has a life span of about a year. “⚡” flashes in red to inform you that it needs to be replaced.

Preparing the Camcorder

Attaching and Detaching the Color Viewfinder Unit

E

Attaching the Color Viewfinder Unit

1. Slide the viewfinder unit onto the bracket and tighten the locking screw.

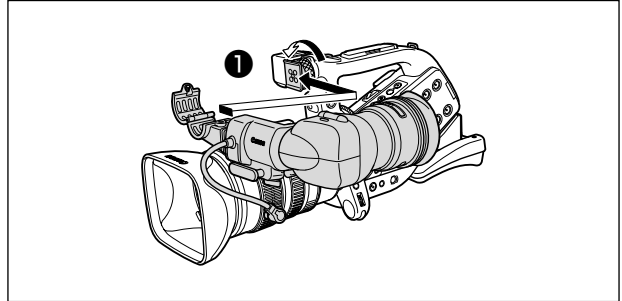

2. Connect the viewfinder cable to the upper socket of the camcorder body.
Align the mark on the cable with the mark on the camcorder.
3. Hook the viewfinder cable onto the cable clamp.

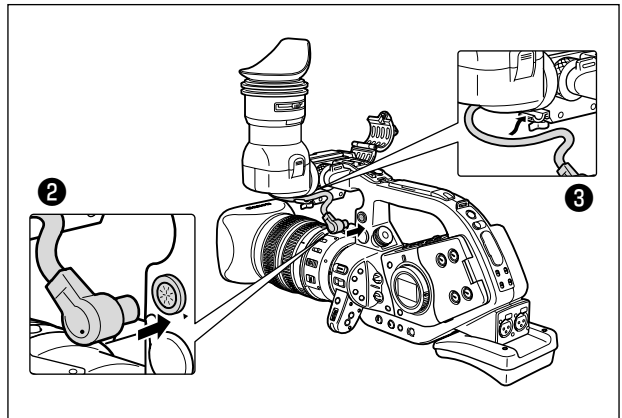

Detaching the Viewfinder Unit

1. Detach the viewfinder cable.
2. Loosen the locking screw and slide the viewfinder unit off the bracket.

Preparation

Detaching and Attaching the Eye Cup

You can change the position of the eye cup for use with either the left or right eye. Detach and reattach the eye cup for use with the left eye.

Detaching the Eye Cup

Detach the eye cup as shown in the illustration.

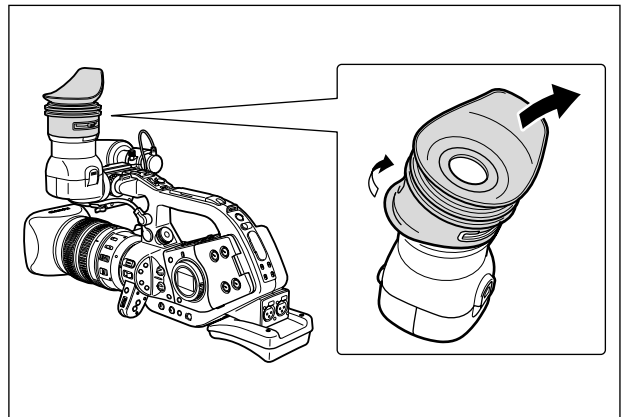

Attaching the Eye Cup

Align the hole for the dioptic adjustment lever with the lever, and pull the eye cup into position.

Right eye use

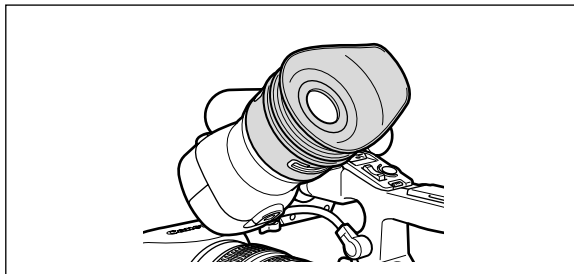

Left eye use

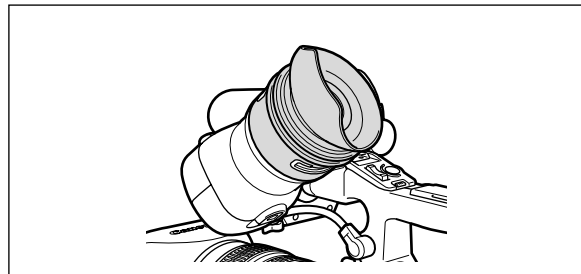

Adjusting the Position of the Viewfinder

The viewfinder position can be changed (right/left, forward/backward).

Right/Left Adjustment

Loosen the locking screw, move the viewfinder to the right/left and tighten the screw.

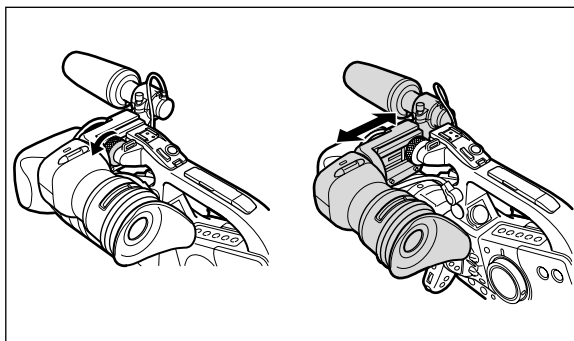

Forward/Backward Adjustment

Loosen the locking lever, move the viewfinder forward/backward and tighten the lever.

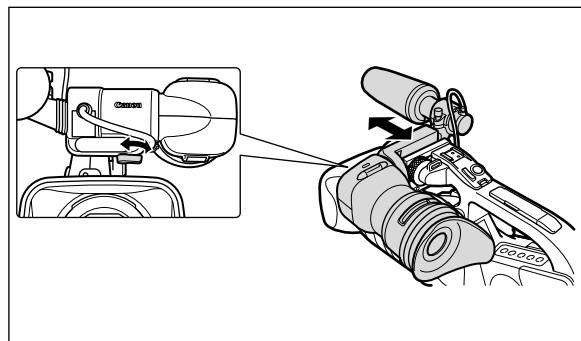

Using the Viewfinder as LCD Panel

You can use the viewfinder as LCD panel by opening the eyepiece adapter.

Press the lock release button and open the eyepiece adapter.

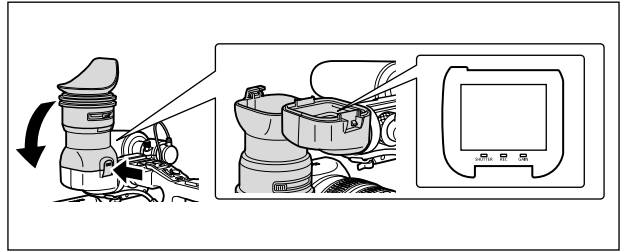

Make sure to close the eyepiece adapter when you are not using the viewfinder as LCD panel.



The screen is slightly brighter when you open the eyepiece adapter.

Dioptric Adjustment

Turn on the camcorder and adjust the dioptric adjustment lever.

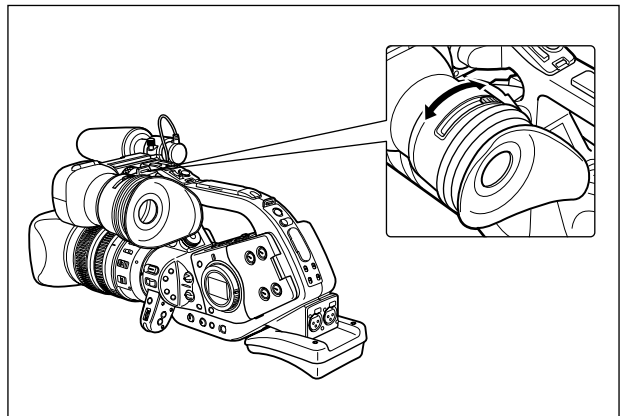

Prevent direct sunlight getting in the viewfinder. The viewfinder LCD may become damaged due to concentration of the light by the lens. Pay special attention when mounting the camcorder on a tripod, or during transportation.

Adjusting the Viewfinder

You can adjust the brightness, contrast, color and sharpness of the viewfinder. These adjustments will not affect the picture of your recording.

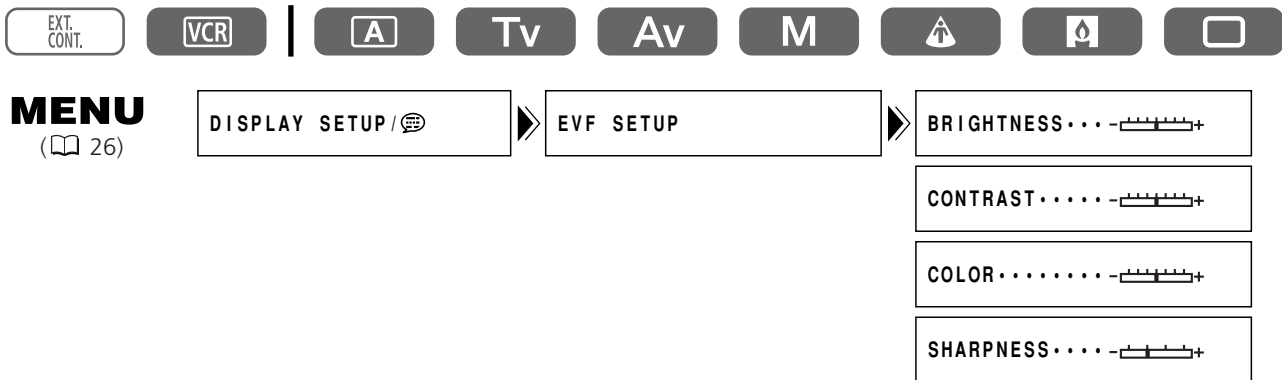

1. Press the MENU button to open the menu.
2. Turn the SET dial to select [DISPLAY SETUP/] and press the SET dial.
3. Turn the SET dial to select [EVF SETUP] and press the SET dial.
4. Turn the SET dial to select [BRIGHTNESS], [CONTRAST], [COLOR], or [SHARPNESS] and press the SET dial.
5. Turn the SET dial up or down to adjust the setting and press the SET dial.
6. Press the MENU button to close the menu.

Attaching the Microphone Unit

1. Loosen the microphone locking screw on the viewfinder unit, open the microphone clamp and insert the microphone into the microphone clamp.
2. Align the mark on the microphone with the mark on the clamp and tighten the screw.
3. Plug the microphone cable to the camcorder's FRONT MIC terminals.

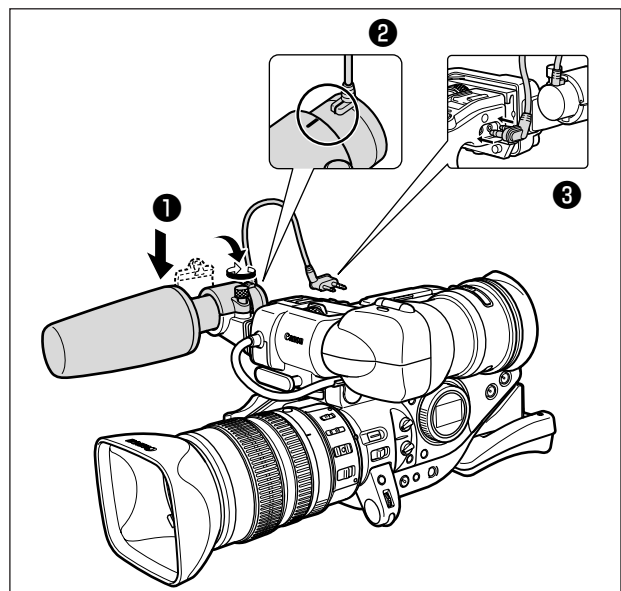

When using a microphone other than the supplied one, attach it to the advanced accessory shoe.

Fastening the Grip Belt

Hold the camcorder with your right hand and adjust the belt with your left.

Adjust the grip belt so that you can reach the zoom lever with your index and middle finger, and the start/stop button with your thumb.

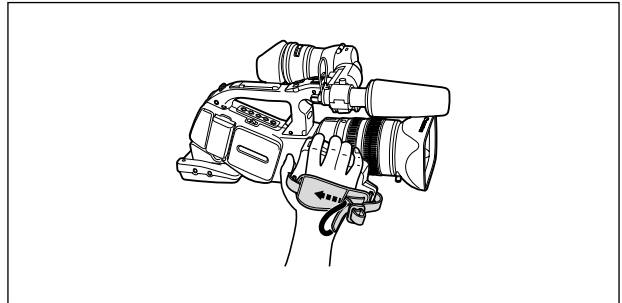

Attaching the Shoulder Strap

Pass the ends through the strap mount and adjust the length of the strap.

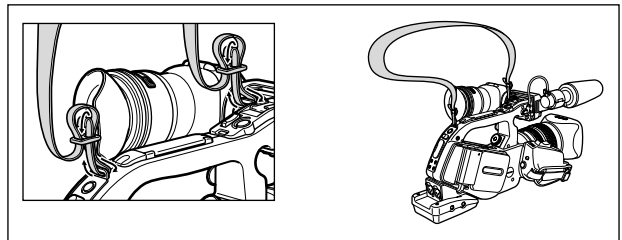

Be careful not to drop the camcorder when adjusting the strap.

Attaching the Adapter Holder

Attach the adapter holder to use the optional CH-910 Dual Battery Charger/Holder or a commercially available wireless microphone receiver.

1. Attach the adapter holder and secure it by tightening the screws.

2. Adjust the position of the support bars.

When using the optional CH-910, hook it onto the support bars and secure it with the stop lever. To detach the CH-910, press the stop lever in the direction of the arrow and pull it off the support bars.

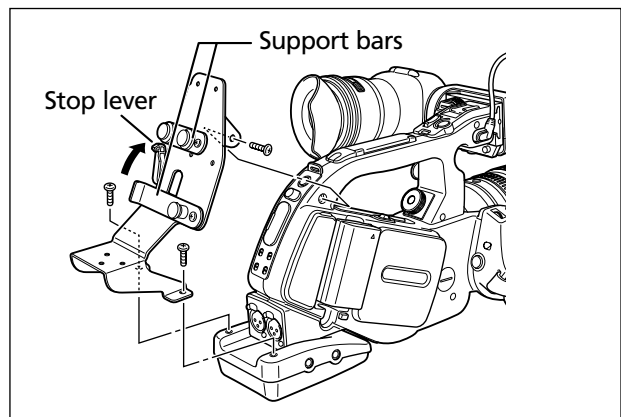

Preparing the Lens

Refer also to the instruction manual of the lens.

Mounting the Lens

1. Set the POWER dial to OFF.
2. Remove the dust caps from the camcorder and the lens.
3. Align the red mark on the lens with the red mark on the camcorder and turn the lens clockwise until it clicks.

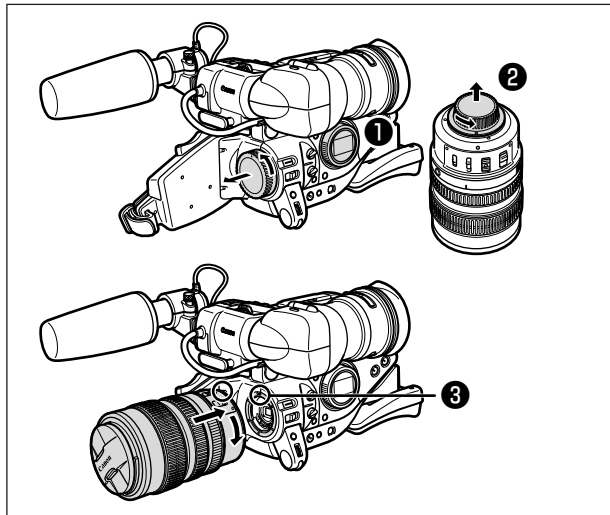

Unmounting the Lens

1. Set the POWER dial to OFF.
2. Slide the LENS RELEASE switch, turn the lens counter-clockwise until it stops and remove the lens.
3. Attach the dust caps to the camcorder and the lens.

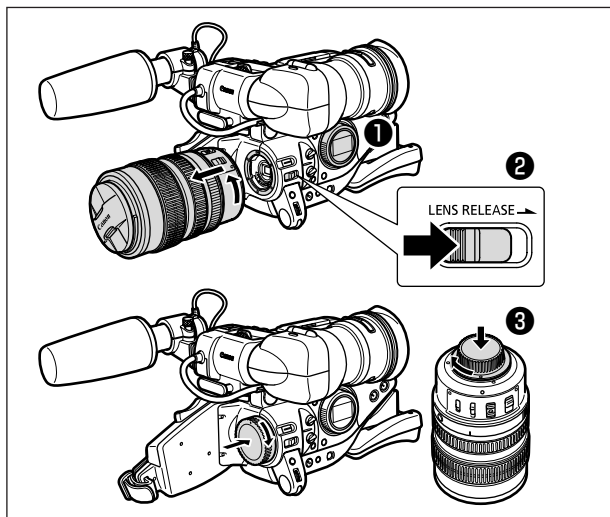

- Be careful not to drop the lens or camcorder when mounting/unmounting the lens.
- Avoid direct sunlight or strong light sources when mounting/unmounting the lens.
- The XL mount is not compatible with the VL mount.
- Do not touch the lens, lens mount and the interior of the mount, or expose them to dust or dirt. If necessary, clean it with a dry soft cloth (make sure to turn off the camcorder during cleaning).

Attaching the Lens Hood

Attach the lens hood to shade the lens from stray light and to protect the lens.

1. Place the lens hood on the front of the lens and screw it clockwise until the Canon logo appears on top.

- Be careful not to deform the lens hood.
- Make sure that the lens hood is aligned with the thread.

2. Tighten the locking screw.

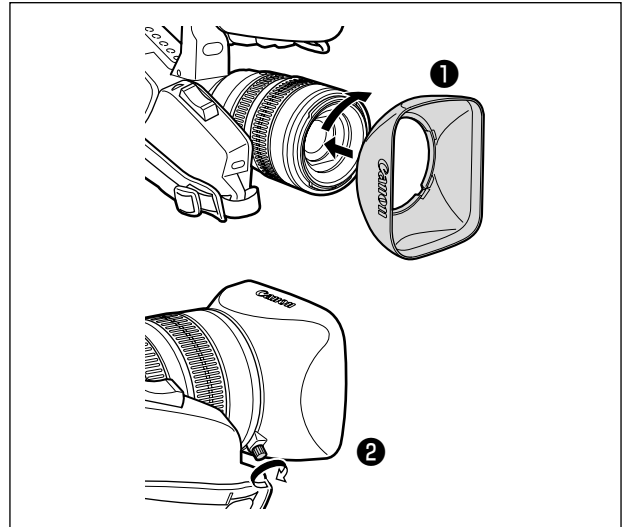

Using the Wireless Controller

Point it at the camcorder's remote sensor when you press the buttons.

The camcorder has three remote sensors, two at the front and one at the back.

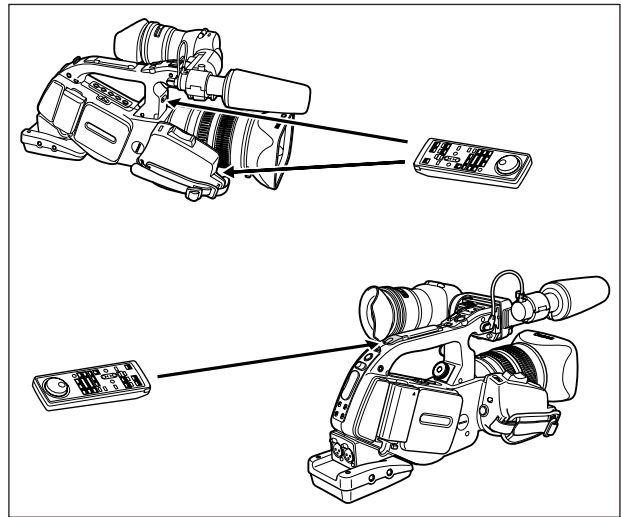

Inserting Batteries

The wireless controller operates with two AAA (R03) batteries.

1. **Open the battery cover.**
2. **Insert the batteries following the + and – markings.**
3. **Close the battery cover.**

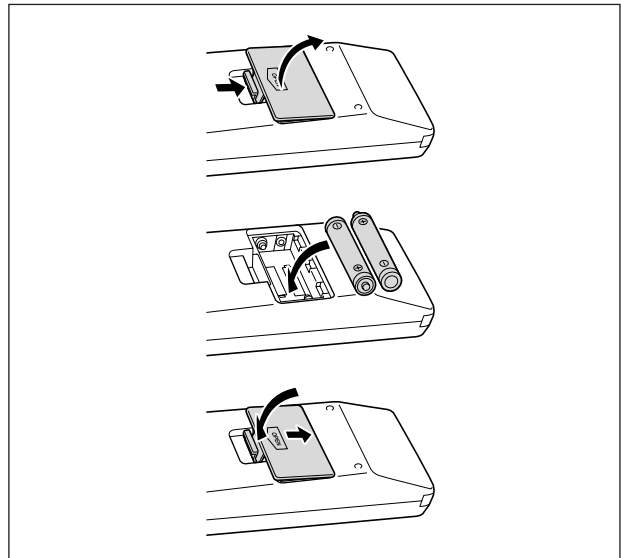

- Camcorder and wireless controller are equipped with 2 remote sensor modes (95). If the wireless controller does not work, check if camcorder and wireless controller are set to the same mode.
- When the camcorder cannot be operated with the wireless controller, or when it can only be operated in very close range, replace the batteries. Make sure to replace both batteries at the same time.
- The wireless controller may not work properly when the remote sensor is subjected to strong light sources or direct sunlight.

Loading/Unloading a Cassette

Use only videocassettes marked with the Mini DV logo.

1. Slide the EJECT switch to open the cassette compartment cover.

The cassette compartment opens automatically.

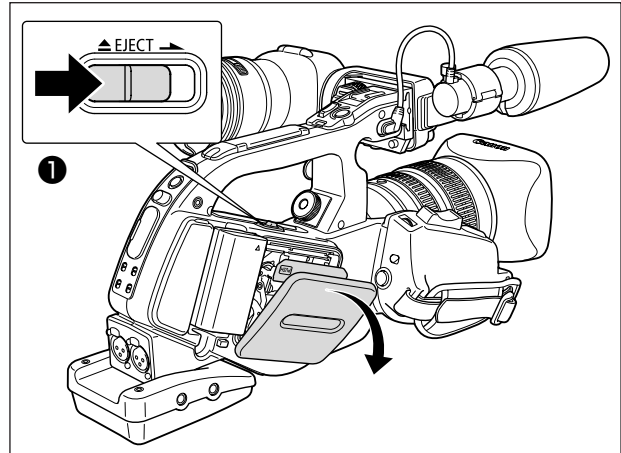

2. Load/unload the cassette.

- Load the cassette with the window facing outward.
- Unload the cassette by pulling it straight out.

3. Press the **PUSH** mark on the cassette compartment until it clicks.

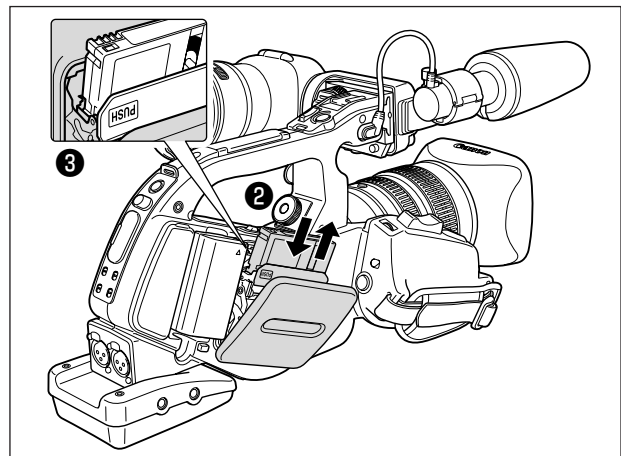

4. Wait for the cassette compartment to retract automatically and close the cassette compartment cover.

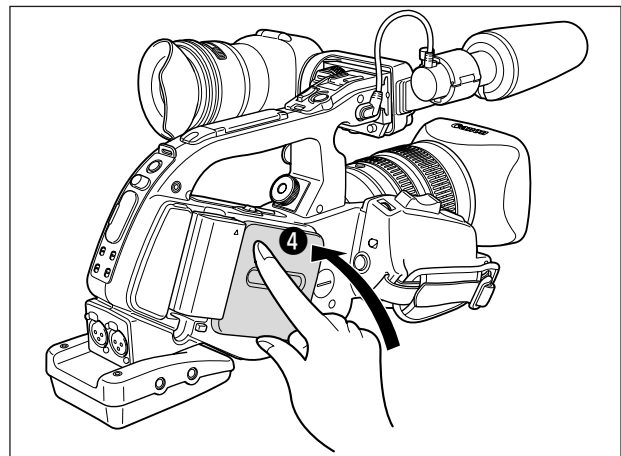

○ Do not interfere with the cassette compartment while it is opening or closing automatically, or attempt to close the cover before the cassette compartment has fully retracted.

○ Be careful not to get your fingers caught in the cassette compartment cover.



If the camcorder is connected to a power source, cassettes can be loaded/unloaded even if the POWER dial is set to OFF.

Menus and Settings

Many of the camcorder's functions are selected from menus that appear on the screen.

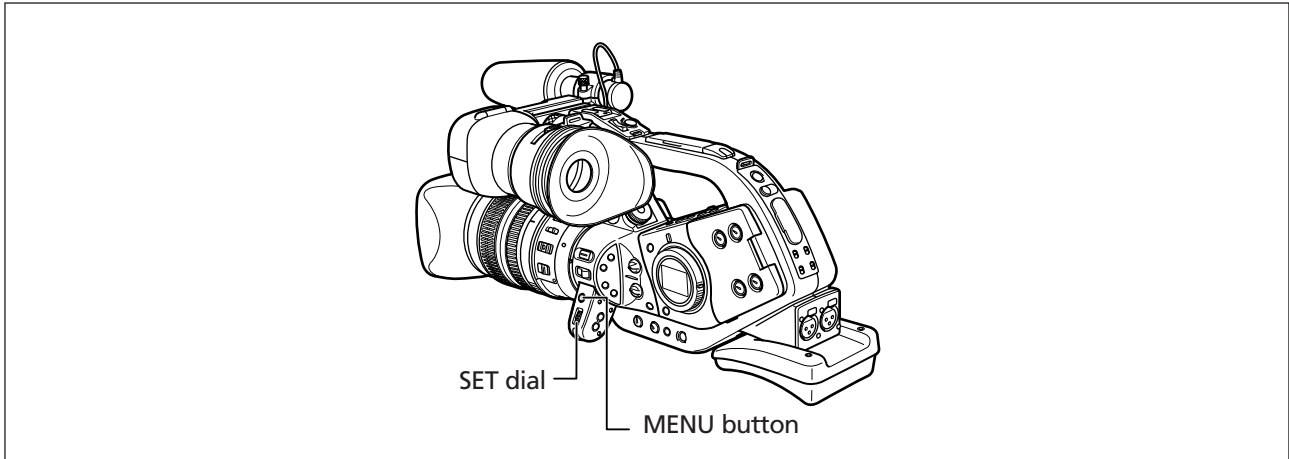

Selecting Menus and Settings

1. Press the MENU button to open the menu.
2. Turn the SET dial to select a submenu and press the SET dial.
3. Turn the SET dial to select a menu item and press the SET dial.
4. Turn the SET dial to select a setting option and press the SET dial.
5. Press the MENU button to close the menu.









- Pressing the MENU button at any time closes the menu.
- Items that are not available appear in purple.
- You may find it more convenient to use the wireless controller to operate the menu. Press the MENU button on the wireless controller to open or close the menu. Use the select buttons in place of the SET dial and press the SET button in place of pressing the SET dial.

Menu and Default Settings





Default settings are shown in boldface.

CAMERA MENU

Submenu	Menu Item	Setting Options				
TIME CODE	FRAME SETTNG	DROP* , NON-DROP	47			
	COUNT-UP	REC-RUN , REC-RUN PS., FREE-RUN*				
	START VALUE	SET , RESET				
CAMERA SETUP	24p MODE SEL	2:3 , 2:3:3:2	45			
	ZEBRA	ON , OFF	66			
	ZEBRA LEVEL	80, 85, 90 , 95, 100	67			
	SKIN D.SET	HUE				
		CHROMA				
		AREA				
		Y LEVEL				
		SKIN DETAIL	OFF , HIGH  , MIDDLE  , LOW 			
	ZOOM HANDLE	LOW, MIDDLE , HIGH	38			
	F SPEED PSET**	LOW, MIDDLE, HIGH	42			
	CLEAR SCAN		73			
	SELF TIMER	ON  , OFF	81			
	INTERVAL T.	ON , OFF	79			
INTERVAL	30sec , 1min, 5min, 10min					
	INT. REC TIME	0.5sec , 1sec, 1.5sec, 2sec				
CUSTOM PRESET	PRESET SETUP	SEL PRESET	1 PRESET_A , 2 PRESET_B, 3 PRESET_C	70		
		 /CLEAR	CANCEL , PROTECT  , CLEAR			
		GAMMA	NORMAL , CINE			
		KNEE	HIGH, MIDDLE , LOW			
		BLACK	STRETCH, MIDDLE , PRESS			
		COLOR MATRIX	NORMAL , CINE			
		COLOR GAIN				
		COLOR PHASE				
		R GAIN				
		G GAIN				
		B GAIN				
		V DETAIL	NORMAL , LOW			
		SHARPNESS				
		CORING				
		SETUP LEVEL				
		MASTER PED.				
		NR	OFF , HIGH, MIDDLE, LOW			
		READ PRESET	SEL PRESET		1 PRESET_A , 2 PRESET_B, 3 PRESET_C	71
			SEL POSITION			

* Cannot be selected in 24p mode.

** Can only be selected when a lens with focus preset function is mounted.

Submenu	Menu Item	Setting Options	📖
VCR SETUP	REC MODE	SP, LP	83
	POWER SAVE	SHUT OFF, VCR STOP	33
	USR BIT DATA	SET, CLEAR	49
AUDIO SETUP	AUDIO MODE	16bit, 12bit CH 1/2 , 12bit CH 1/2 , 3/4	50
	1kHz TONE	OFF, -12dB, -20dB	78
	AUD.M.SET	NORMAL, LINE OUT	53
	R-XLR GAINUP	OFF, 12dB	51
DISPLAY SETUP/ 	EVF SETUP	BRIGHTNESS	20
		CONTRAST	
		COLOR	
		SHARPNESS	
	CENTER MARK	ON, OFF	35
	TV SCREEN	ON, OFF	104
	AUDIO LEVEL	ON, OFF	53
	GUIDE INFO	OFF, CUSTOM KEYS, D/T DISPLAY	31, 74
	LANGUAGE 	ENGLISH, 中文, 日本語	84
	DATE FORMAT		84
	USR BIT DISP	ON, OFF	49
SYSTEM	CUSTOM KEY 1	TIME CODE, INDEX WRITE, ZEBRA, VCR STOP, TV SCREEN, ZOOM HANDLE, AUDIO LEVEL, (NONE)	75
	CUSTOM KEY 2	TIME CODE, INDEX WRITE, ZEBRA, VCR STOP, TV SCREEN, ZOOM HANDLE, AUDIO LEVEL, (NONE)	
	WL.REMOTE	 1,  2, OFF 	95
	TALLY LAMP	ON, OFF	83
	T.ZONE/DST		30
	D/TIME SET		30
	CHAR.REC	ON, OFF	83
	DV CONTROL	ON, OFF	82

VCR MENU

Submenu	Menu Item	Setting Options	
TIME CODE	FRAME SETTNG	DROP, NON-DROP	47
	COUNT-UP	REC-RUN, REC-RUN PS., FREE-RUN	
	START VALUE	SET, RESET	
VCR SETUP	REC MODE	SP, LP	83
	AV→DV	ON, OFF	100
	USR BIT DATA	SET, CLEAR	49
AUDIO SETUP	SEL AUDIO CH	CH 1/3 /CH 2/4 , CH 1/3 /CH 1/3 , CH 2/4 /CH 2/4	89
	MIX SELECT	VARIABLE, FIXED	89
	AUDIO MODE	16bit, 12bit CH 1/2 , 12bit CH 1/2 , 3/4	50
	R-XLR GAINUP	OFF, 12dB	51
DISPLAY SETUP/ 	EVF SETUP	BRIGHTNESS	20
		CONTRAST	
		COLOR	
		SHARPNESS	
	TV SCREEN	ON, OFF	104
	AUDIO LEVEL	ON, OFF	53
	DISPLAYS	ON, OFF<PLAYBK>	104
	6SEC.DATE	ON, OFF	94
	DATA CODE	DATE/TIME, CAMERA DATA, CAM.& D/T	93
	D/TIME SEL.	DATE, TIME, DATE & TIME	93
	CUSTOM KEYS	ON, OFF	74
	LANGUAGE 	ENGLISH, 中文, 日本語	84
	DATE FORMAT		84
	USR BIT DISP	ON, OFF	49
SYSTEM	CUSTOM KEY 1	TIME CODE, TV SCREEN, DATA CODE, AUDIO LEVEL, (NONE)	75
	CUSTOM KEY 2	TIME CODE, TV SCREEN, DATA CODE, AUDIO LEVEL, (NONE)	
	WL.REMOTE	1, 2, OFF 	95
	TALLY LAMP	ON, OFF	83
	T.ZONE/DST		30
	D/TIME SET		30

Setting the Time Zone, Date and Time

Set the time zone, date and time when you first start using your camcorder, or when you have replaced the backup battery.

Setting the Time Zone/Daylight Saving Time

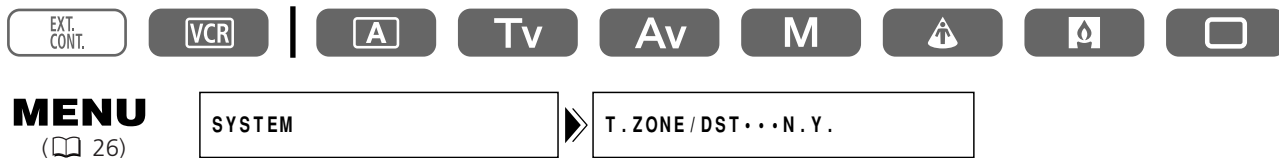

1. Press the MENU button to open the menu.
2. Turn the SET dial to select [SYSTEM] and press the SET dial.
3. Turn the SET dial to select [T.ZONE/DST] and press the SET dial.
The time zone setting appears (see table on the next page). The default setting is New York.
4. Turn the SET dial to select the setting option that represents your time zone and press the SET dial.

To adjust for daylight saving time, select the time zone with the ☀ next to the area.

Setting the Date and Time



5. Turn the SET dial to select [D/TIME SET] and press the SET dial.
The year display starts flashing.
6. Turn the SET dial to select the year, and press the SET dial.
 - The next part of the display starts flashing.
 - Set the month, day, hours and minutes in the same way.
7. Press the MENU button to close the menu and to start the clock.

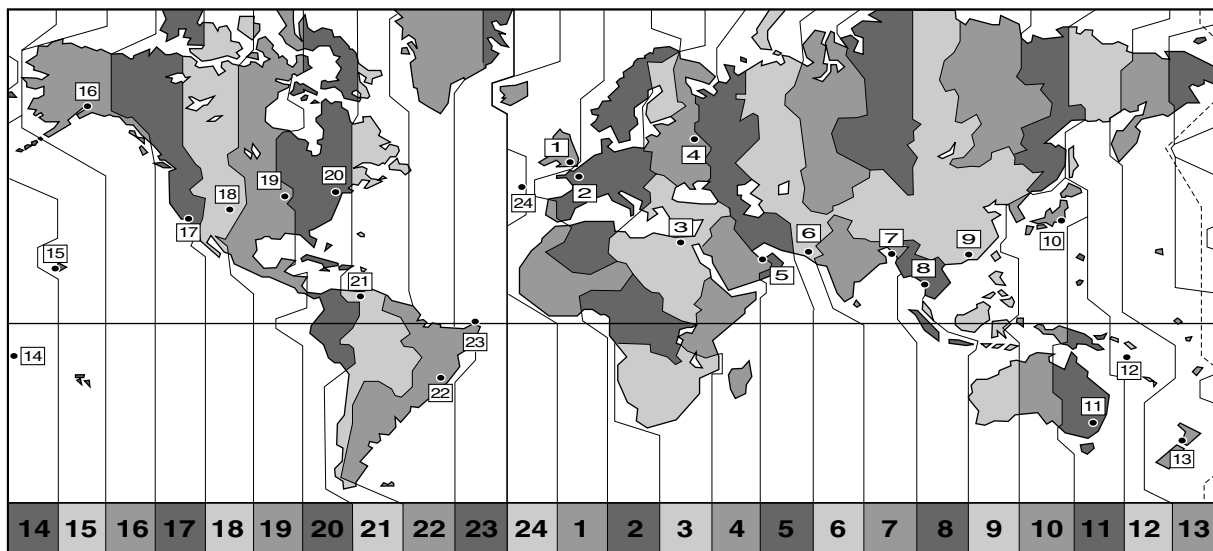

No.	Time zone	No.	Time zone
1	LONDON	13	WELLGTN (Wellington)
2	PARIS	14	SAMOA
3	CAIRO	15	HONOLU. (Honolulu)
4	MOSCOW	16	ANCHOR. (Anchorage)
5	DUBAI	17	L.A. (Los Angeles)
6	KARACHI	18	DENVER
7	DACCA	19	CHICAGO
8	BANGKOK	20	N.Y. (New York)
9	H. KONG (Hong Kong)	21	CARACAS
10	TOKYO	22	RIO (Rio de Janeiro)
11	SYDNEY	23	FERNAN. (Fernando de Noronha)
12	SOLOMON	24	AZORES



Once you have set time zone, date and time, you do not need to reset the clock each time you travel to another time zone. Just set the time zone to the one of your destination, and the camcorder automatically adjusts the clock.

Displaying Date and Time during Recording

You can display the date and time in the lower left corner of the screen.



MENU
(26)



Open the menu and select [DISPLAY SETUP/ [clock icon]]. Select [GUIDE INFO], set it to [D/T DISPLAY] and close the menu.

Recording

Before You Begin Recording

Make a test recording first to check if the camcorder operates correctly. If necessary, clean the video heads (📖 110).

Recording



1. Remove the lens cap.
2. Press the button and set the POWER dial to a recording program.

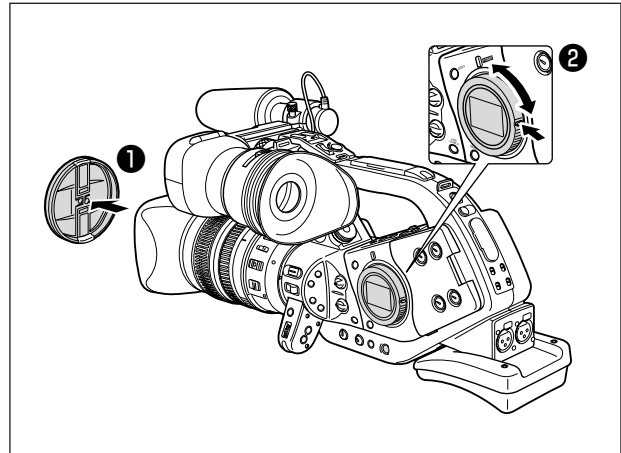

3. Press the start/stop button to begin recording.
 - The tally lamp starts flashing, and the REC lamp on the viewfinder lights up.
 - Press the start/stop button again to pause recording.

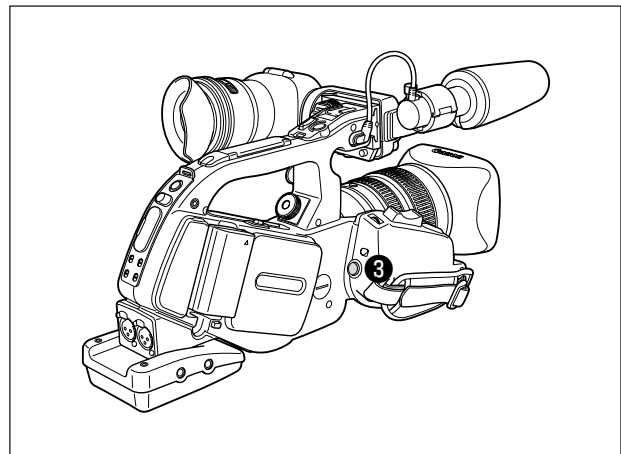

When You Have Finished Recording

1. Set the POWER dial to OFF.
2. Replace the lens cap.
3. Unload the cassette.
4. Disconnect the power source.



- Wait until the tape counter stops completely before you start recording.
- When you do not remove the cassette, you can record the next scene without producing any noise or blank sections between the recordings even if you turn the camcorder off.

Low-angle Recording

The carrying handle is equipped with a duplicate set of recording and zoom controls, ideal for low-angle recording. Slide the LOCK lever to the right to prevent accidental operation.

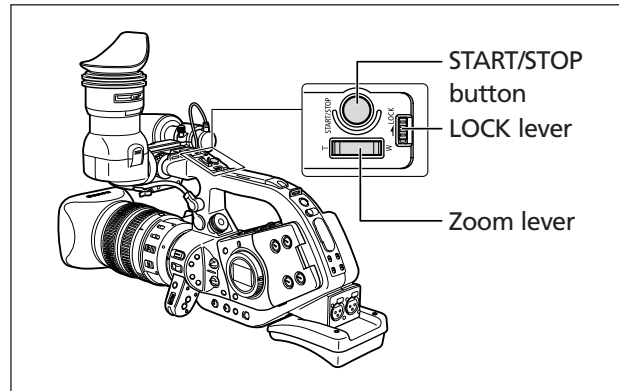

Power Saving Mechanisms

STANDBY Button

Pressing the STANDBY button for more than 1 second in record pause or VCR STOP mode activates the power save mode ("ENTERING POWER STANDBY" appears). This shuts the power down to the camera and VCR sections while maintaining the camera settings. The camcorder retains the settings of exposure lock and color bars. Press the STANDBY button again to turn the camcorder back on.

Power Save Function

The camcorder activates the power save function after 5 minutes in record pause mode to protect tape and video heads. You have the option to set the camcorder to shut off (SHUT OFF) or to turn off the VCR section leaving the camera section turned on (VCR STOP). In VCR STOP mode, the camcorder retains camera settings such as aperture and shutter speed, so you can adjust the camera section without worrying about the automatic shut-off. The VCR STOP function can also be assigned to a custom key (📖 74).



MENU

(📖 26)

VCR SETUP

▶ POWER SAVE...SHUT OFF

Open the menu and select [VCR SETUP]. Select [POWER SAVE], select a setting option and close the menu.



- When set to [SHUT OFF]: To turn the camcorder on, press the STANDBY button or set the POWER dial to OFF and then back to a recording program.
- When set to [VCR STOP]: To start recording, press the start/stop button. To go into record pause mode, use the custom key (📖 74).

Screen Displays during Recording

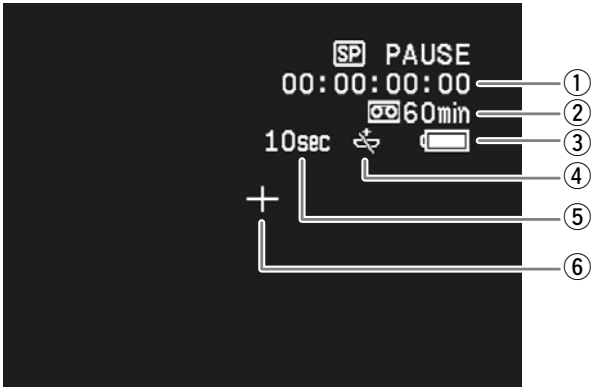

① Time code

You can select between drop frame or non-drop frame time code (☞ 47).

② Remaining tape

Indicates the remaining time of the tape in minutes. "END" flashes when the tape reaches the end.

- When the time left is less than 15 seconds, the remaining tape time may not appear.
- Depending on the type of the tape, the indication may not be displayed correctly.

③ Remaining battery charge

The battery symbol indicates the charge status of the battery pack.



- "X" starts flashing in red when the battery pack is empty.
- When you attach an empty battery pack, the power may turn off without displaying "X".
- The actual battery charge may not be indicated accurately depending on the condition under which battery pack and camcorder are used.

④ When "X" flashes

"X" flashes in red when the lithium button battery is not installed, or when it needs replacing.

⑤ Recording reminder

The camcorder counts from 1 to 10 seconds when you start recording. This is helpful to avoid scenes that are too short.

⑥ Center marker

Use the center marker to accurately frame subjects (☞ 35).

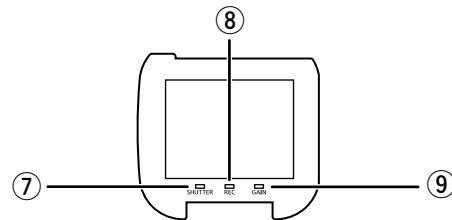

⑦ SHUTTER lamp

Lights up when the shutter speed is changed from the following:

60i	1/60 of a second
30p	1/30 of a second
24p	1/48 of a second

⑧ REC lamp

Lights up during recording.

The REC lamp starts flashing when the remaining tape is less than 5 minutes (it does not flash when the remaining tape information is not displayed on the screen.)

⑨ GAIN lamp

Lights up when the AGC (auto gain control) becomes set to -3 dB or +3 dB or higher.



You can select the amount of information shown on the screen from full, partial or no display. The setting changes with each press of the EVF DISPLAY button.

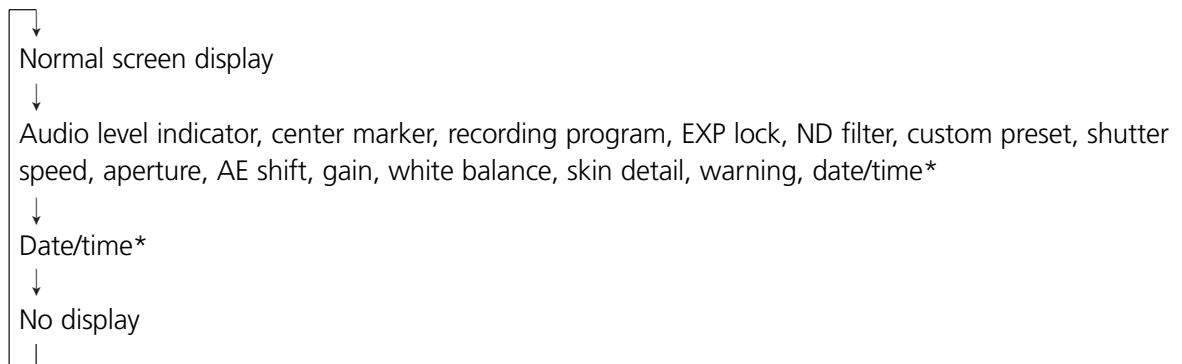

* When [GUIDE INFO] is set to [D/T DISPLAY].

Displaying the Center Marker

Use the center marker to accurately frame subjects.

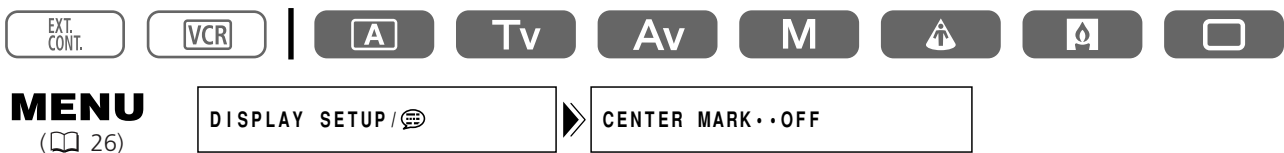

Open the menu and select [DISPLAY SETUP/]. Select [CENTER MARK], set it to [ON] and close the menu.

Reviewing and Searching when Recording

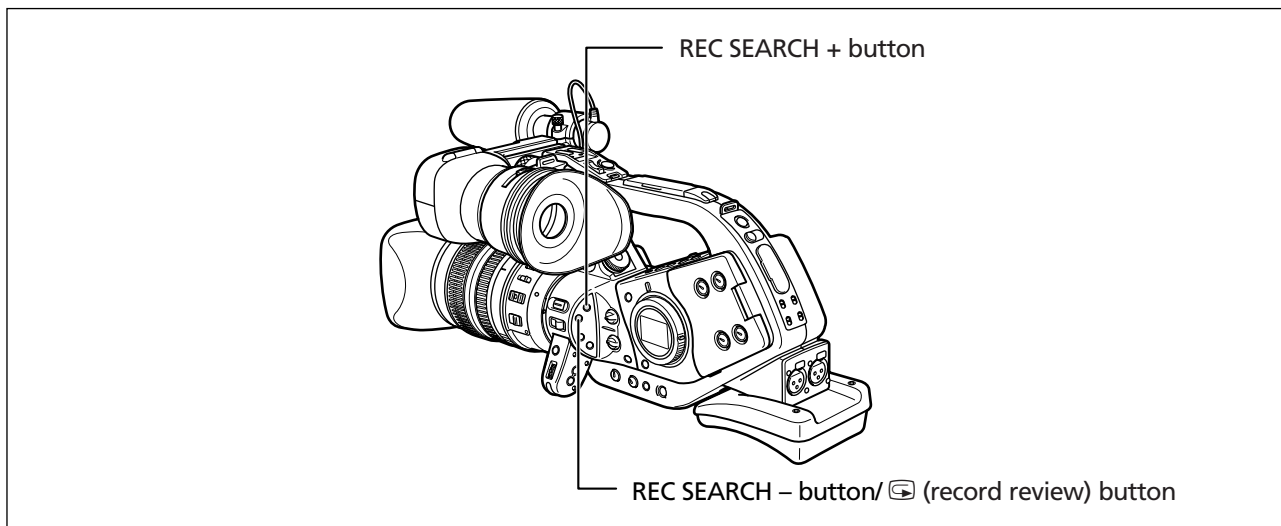

Record Review



In record pause mode, this function allows you to review the last few seconds of your recording to check if it has been recorded properly.

Press and release the (record review) button.

The camcorder rewinds the tape, plays back the last few seconds, and returns to record pause mode.

Record Search



In record pause mode, this function allows you to play back the tape (forward or reverse) to locate the point where you wish to begin recording.

Press and hold the REC SEARCH + button (forward) or – button (reverse).

- Release the button at the point you wish to begin recording.
- The camcorder returns to record pause mode.

End Search

You can use this function to locate the end of the last recorded scene.

E

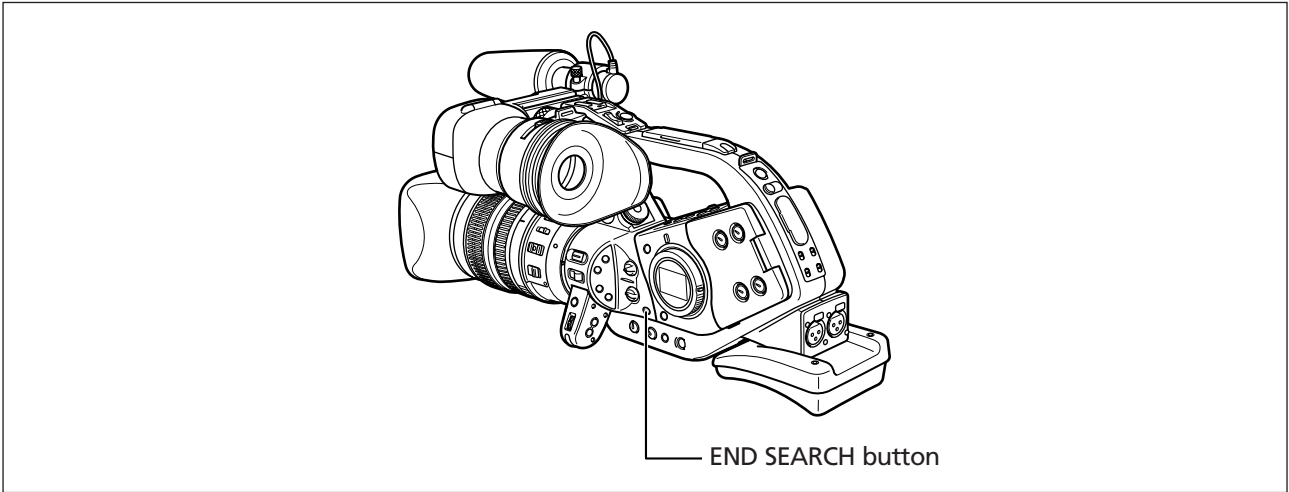

Press the END SEARCH button.

- "END SEARCH" appears.
- The camcorder rewinds/fast forwards the tape, plays back the last few seconds of the recording and stops the tape.
- Pressing the button again cancels the search.



- End search cannot be used once you unload the cassette.
- End search may not work properly if a blank section exists on the tape.

Recording

Zooming

You can operate the zoom from either the side grip or the carrying handle. You can also use the zoom ring on the zoom lens or the zoom buttons on the wireless controller.

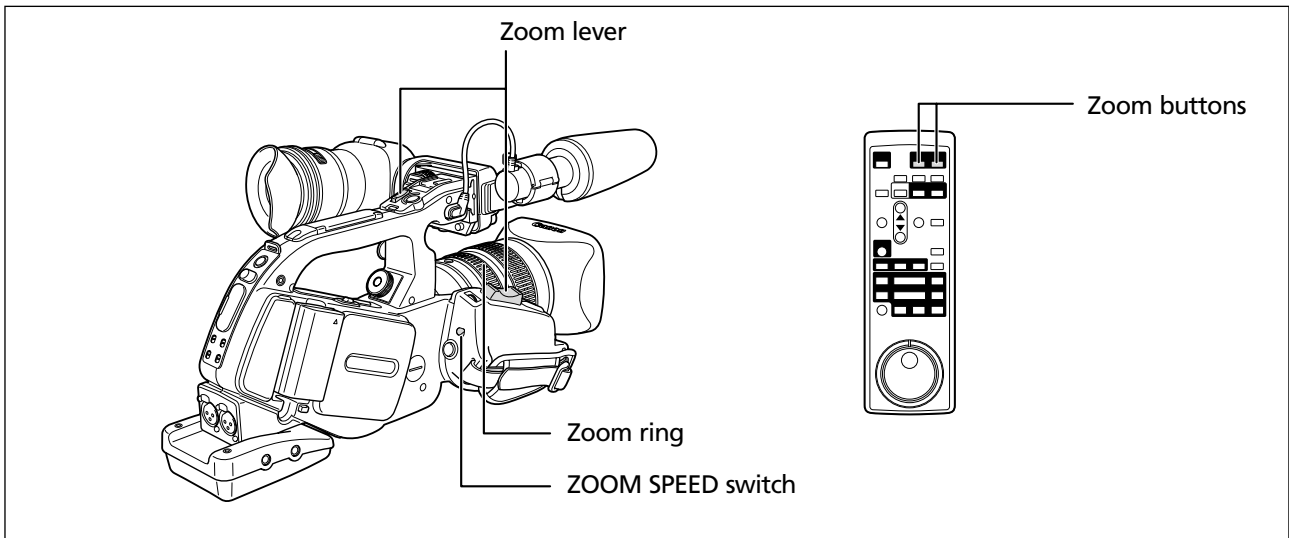

Move the zoom lever toward **W** to zoom out (wide-angle). Move it toward **T** to zoom in (telephoto).

About the Variable Zoom Speeds

Zoom lever on the side grip:

When the ZOOM SPEED switch is set to CONSTANT, the zoom speed is constant. However, you can change the zoom speed with the dial above (a number indicating the level is displayed next to the zoom indicator).

When the ZOOM SPEED switch is set to VARIABLE, the zoom speed is linked to how hard you move the zoom lever.

Zoom speed with 20x L IS Lens (from wide-angle to telephoto):

CONSTANT: Level 1: approx. 60 seconds
Level 16: approx. 3.5 seconds

VARIABLE: Up to approx. 10 seconds

Zoom speed varies depending on the lens.

Zoom lever on the carrying handle:

You can select the zoom speed from low, middle and high.

MENU
(26)

CAMERA SETUP



ZOOM HANDLE · MIDDLE

Open the menu and select [CAMERA SETUP]. Select [ZOOM HANDLE], select the zoom speed and close the menu.

Zoom ring:

The zoom speed is linked to the speed you turn the zoom ring.

Zoom buttons on the wireless controller:

The zoom speed is constant and cannot be adjusted.

Zoom Preset (Lenses Equipped with the Zoom Preset Function)

This function enables any given zoom setting to be memorized and to return to the zoom setting instantly.

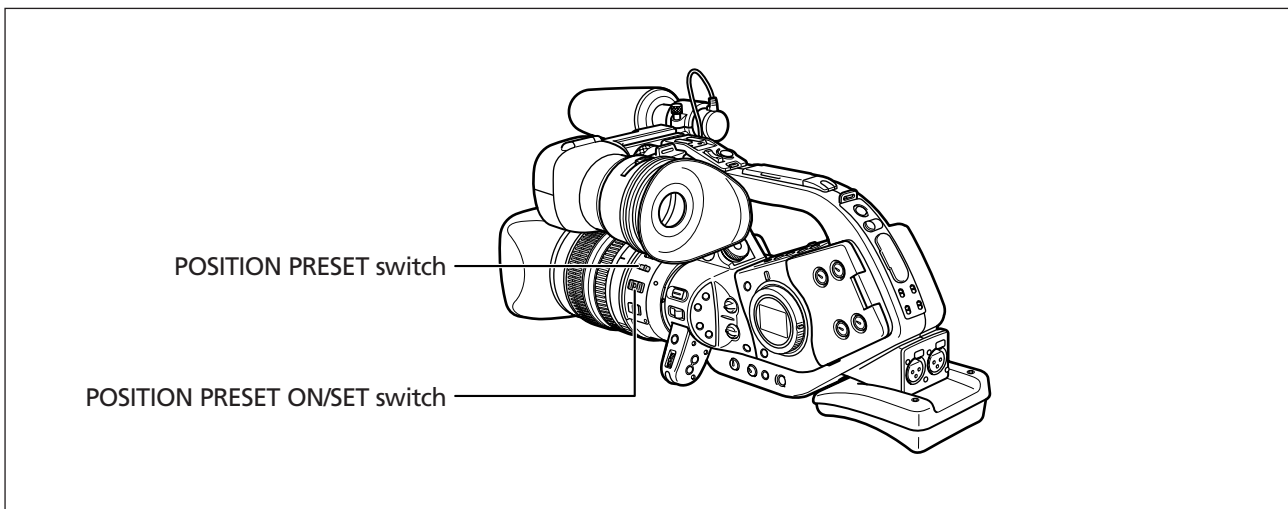
**Presetting the Zoom**

1. Set the POSITION PRESET switch to ZOOM.

2. Move the POSITION PRESET ON/SET switch to SET.

The preset zoom position appears in yellow on the zoom indicator.

Returning to the Preset Zoom Position

Move the POSITION PRESET ON/SET switch to ON.

The camcorder returns to the preset zoom position.



- The preset setting is canceled when you attach the optional Extender XL 1.6x or mount a lens with different magnification.
- The camcorder uses the zoom speed of the CONSTANT setting when returning to the preset zoom position.

Adjusting the Focus

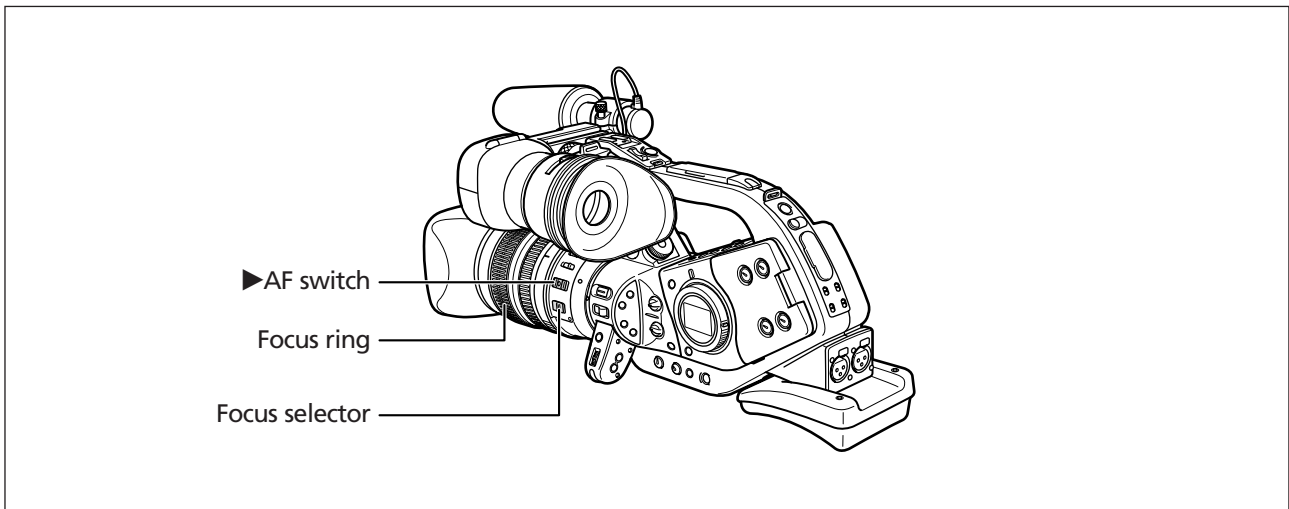

Autofocus (Lenses Equipped with the Autofocus Function)

Autofocus is set when the focus selector on the lens is set to AF. The camcorder uses TTL autofocus system with a focusing range of 0.8 in. (2 cm) (at wide-angle from the front of the lens barrel) to ∞ . The camcorder focuses on the subject in the center of the screen.

Temporary Focus Override

Turn the focus ring during autofocus to focus manually.

Autofocus will resume as soon as you take your hand away from the focus ring.



When recording under bright conditions, the camcorder sets a small aperture value, and the picture may appear blurred. This may be more noticeable at wide-angle. When you are using a lens with built-in ND filter, turn it on/off according to the screen display (43).



- When recording under dark conditions, the focusing range narrows and the picture may appear blurred.
- In 30p and 24p mode, autofocus takes longer than in the 60i mode.
- Autofocus may not work well on the following subjects. In such case, focus manually.
 - Reflective surfaces
 - Subjects with low contrast or without vertical lines
 - Fast moving subjects
 - Through dirty or wet windows
 - Night scenes

Manual focus

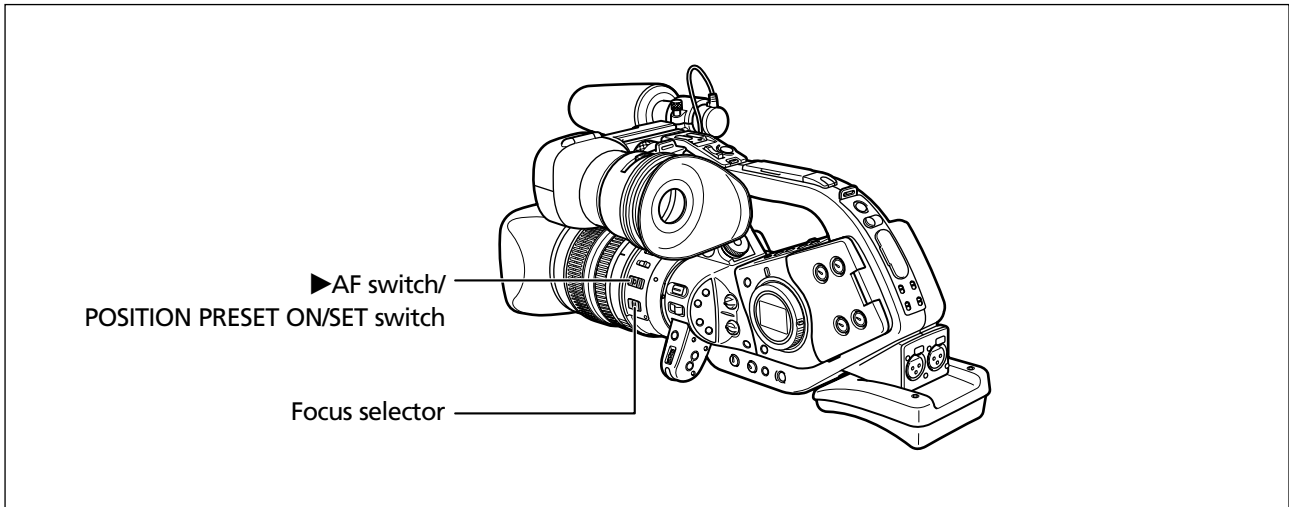

1. Lenses equipped with autofocus function: Slide the focus selector on the lens to **M**.
2. Zoom into telephoto.
3. Rotate the focus ring to adjust the focus.
4. Operate the zoom to reframe the subject.

If you focus manually then leave the camcorder with the power turned on, you may lose focus on your subject. This possible slight shift in focus is due to a rise in temperature in the camcorder interior and lens. Check the focus before resuming shooting.

Temporary Autofocus

Press the ►AF switch on the lens in the direction of AF and hold it.

Autofocus is activated as long as you hold the ►AF switch.



When using the ►AF switch, make sure the POSITION PRESET switch is set to OFF.

Focus Preset (Lenses Equipped with the Focus Preset Function)

This function enables a focus setting to be memorized and to return to the focus setting instantly. You can also select the speed with which the camcorder returns to the preset focus setting.

Presetting the Focus



1. Set the focus selector to **M**.
"MF" appears.
2. Set the **POSITION PRESET** switch to **FOCUS**.
3. Adjust the focus with the focus ring.
4. Move the **POSITION PRESET ON/SET** switch to **SET**.
"MF" and the focus preset speed appear in yellow.

Setting the Focus Preset Speed

MENU

( 26)

CAMERA SETUP



F SPEED PSET • HIGH

Open the menu and select [**CAMERA SETUP**]. Select [**F SPEED PSET**], select a setting option and close the menu.

The selected speed appears next to "MF".

Returning to the Preset Focus Setting

Move the **POSITION PRESET ON/SET** switch to **ON**.

The camcorder returns to the preset focus setting.



The preset setting resets and sets to OFF when you turn the camcorder off or unmount the lens.

Using the ND Filter (Lenses with Built-in ND Filter)

When recording under bright conditions, the camcorder sets a small aperture value, and the picture may appear blurred. When you are using a lens with built-in ND filter, turn it on/off according to the screen display.

E

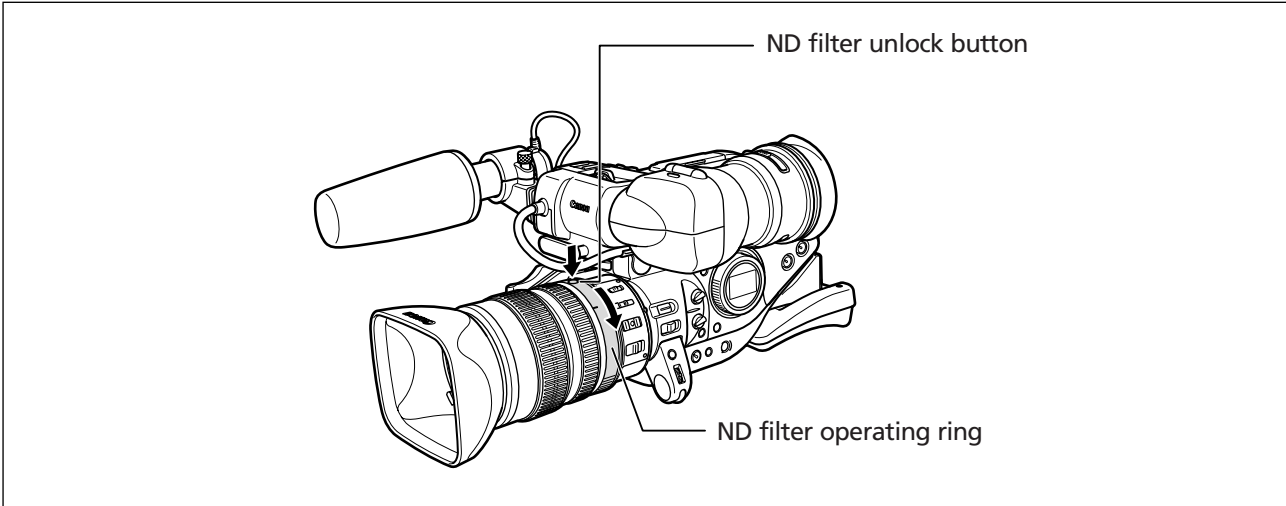

With the 20× L IS Lens: Press the ND filter unlock button and turn the ND filter operating ring.

When the camcorder is set to Easy Recording or Auto mode, following displays appear:

Screen display	What it means	What you should do
No display	ND filter is not activated	-
"ND" displayed	ND filter is activated	-
"ND ON " flashes	ND filter required	Turn on the ND filter
ND " ON " flashes	Lenses with ND filter on/off: External ND filter required Lenses with selectable ND filter density: Higher density or external ND filter required	Select a higher density built-in ND filter or attach an external ND filter to the lens*
ND " OFF " flashes	Built-in ND filter not required	Turn off the ND filter

* If you have no external ND filter available, use the Tv mode and set a high shutter speed, or use the Av mode and set a small aperture value.



- Turning on/off the ND filter changes the aperture setting. Readjust the aperture in Av mode as required.
- Depending on the scene, the color may change when turning on/off the ND filter. In such case, setting a custom white balance may be effective.

Recording

Selecting the Frame Rate

Select from standard 60i, 30p or 24p mode. Furthermore, images captured in 24p mode can be 2:3 pulldown-converted or 2:3:3:2 pulldown-converted.

60i Mode

Records in 60 fps interlace mode, same as TV signals.

30p Mode

Records in 30 fps progressive mode and outputs signals converted into 60 fps interlace.

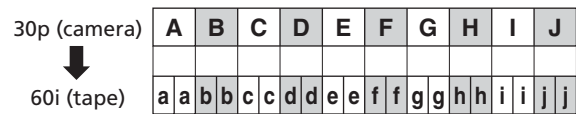

24p Mode

Records in 24 fps progressive mode like movie film cameras, creating a cine-like picture.

24p 2:3 Mode

Signals are converted into 60 fps interlace using the 2:3 pulldown method. This 24p mode is suited for playback on a TV screen.

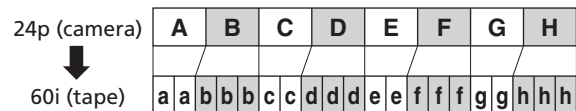

24p 2:3:3:2 Mode

Signals are converted into 60 fps interlace using the 2:3:3:2 pulldown method. This 24p mode is ideal for extracting true 24 frames per second in order to transfer to film.

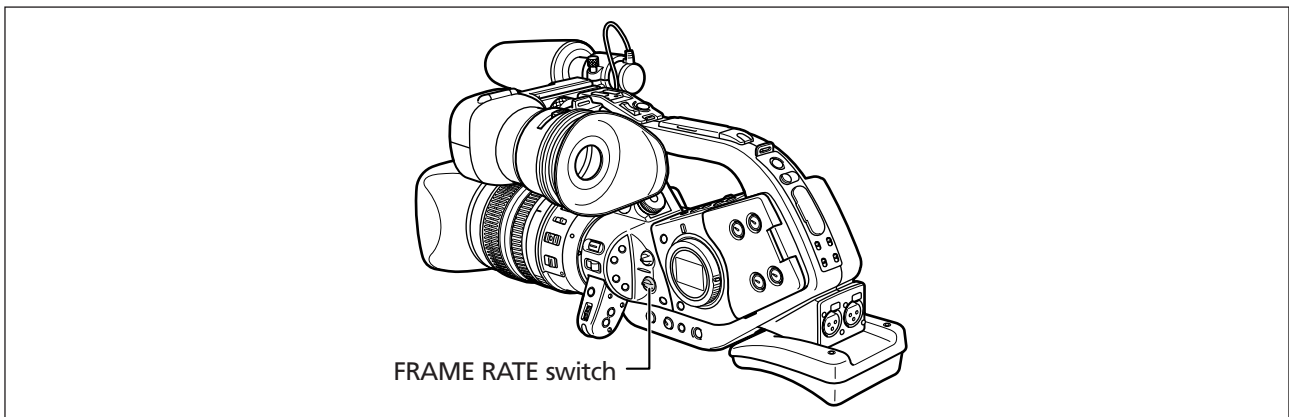
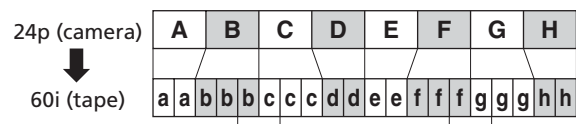

Selecting the Frame Rate



Set the **FRAME RATE** switch to the desired position.

The selected frame rate appears.



- The frame rate does not change when you operate the FRAME RATE switch during recording. It changes once you pause recording.
- In 24p mode, the shutter speeds in Low Light mode will be the same as in the Easy Recording mode. Slow shutter speeds are not available.

Selecting the 24p Pulldown Mode



MENU
(26)

CAMERA SETUP



24 P MODE SEL • 2:3

Open the menu and select **[CAMERA SETUP]**. Select **[24p MODE SEL]**, select a setting option and close the menu.

- When you have selected [2:3], “24p” appears in white.
- When you have selected [2:3:3:2], “24p” appears in orange.



If you are using an editing system not supporting the 2:3:3:2 pulldown method, make sure to record in 24p 2:3 pulldown mode.

Recording in 16:9 Mode

The camcorder uses the full width of the CCD, retaining image quality and providing a larger horizontal angle of view.

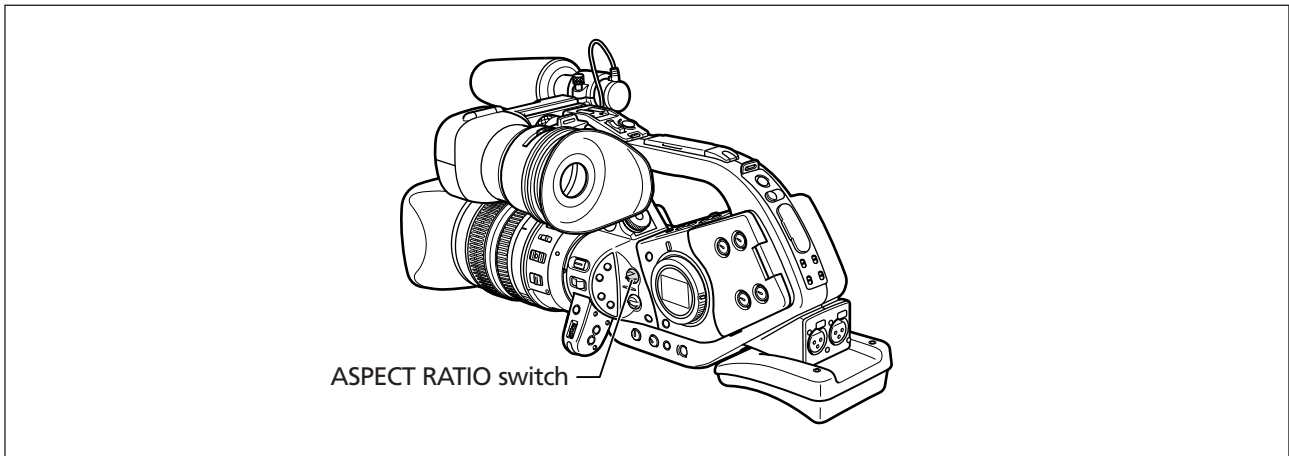

Set the ASPECT RATIO switch to 16:9.

The screen changes to the "letterbox" format.



- If you play back a 16:9 recording on a normal TV, the image appears horizontally squeezed.
- If you connect the camcorder to a TV with an S (S1) terminal or Video ID-1 system, recordings made in the 16:9 mode will be automatically played back in widescreen mode.
- The aspect ratio does not change when you operate the ASPECT RATIO switch during recording. It changes once you pause recording.

Setting the Time Code

Selecting the Frame Setting

In 60i and 30p mode, you can select between drop frame or non-drop frame time code. Drop frame time code synchronizes the time code of 30 fps with the actual frame rate of NTSC video, which is 29.97 fps, by skipping numbers. The non-drop frame time code counts every single video frame. Use the drop frame time code for actual running time, and the non-drop time code for editing.

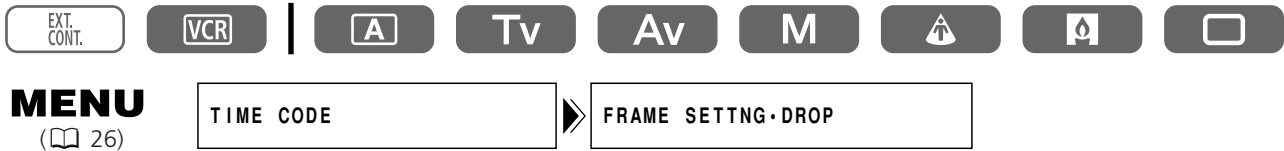

Open the menu and select [TIME CODE]. Select [FRAME SETTING], select a setting option and close the menu.

Selecting the Run Options

In 60i and 30p mode, you can select from record run (REC-RUN), record run preset (REC-RUN PS.) and free-run (FREE-RUN) time code. In 24p mode, you can select from record run or record run preset. With record run, the time code runs only when you are recording. With free run, the time code runs regardless of the operation of the camcorder. With record run preset and free-run, you can select the starting point.

Normally select record-run. Select free-run time code when you wish to record with multiple camcorders set to the same time code.

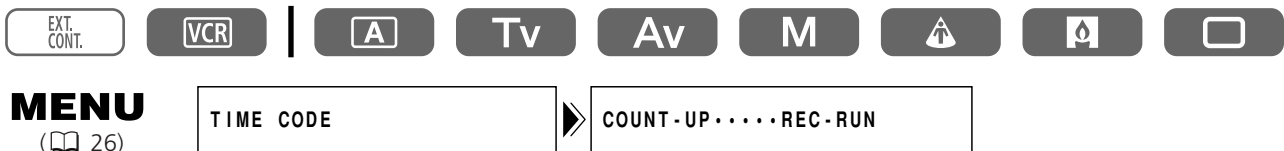

1. Open the menu and select [TIME CODE]. Select [COUNT-UP] and set it to [REC-RUN], [REC-RUN PS.] or [FREE-RUN].

When you selected [REC-RUN]: Close the menu.

When you selected [REC-RUN PS.] or [FREE-RUN]: The starting point set/reset options appear.

When you selected [REC-RUN PS.] or [FREE-RUN]:

2. Select [SET].

The hours display flashes.

3. Turn the SET dial to select the hour and press the SET dial.

- The next part of the display starts flashing.
- Set the minutes, seconds and frames in the same way.

4. Close the menu.



- When setting the free-run time code, the time code starts to run when you press the MENU button in the middle of the setting, or when you press the SET dial after setting the last digits.
- To reset the time code to [00:00:00:00], select [RESET] in step 2.
- In 24p mode, the frame of the time code is set in multiples of 5. When you change to 24p from 60i/30p, the starting point will automatically become a multiple number of 5.
- When you mix drop frame and non-drop frame time codes, the time code at recording start may be discontinuous.
- When recording over existing scenes: When a time code discontinuity occurred near the recording start point, the time code at recording start may be discontinuous.
- When the backup battery is installed, the free-run time code continues to run even when you disconnect the battery pack.

Setting the User Bit

The user bit display works on the hexadecimal system that consists of a mixture of eight numbers or letters. There are sixteen possible characters, numbers 0 to 9 and letters A to F. This is useful for labeling tapes.

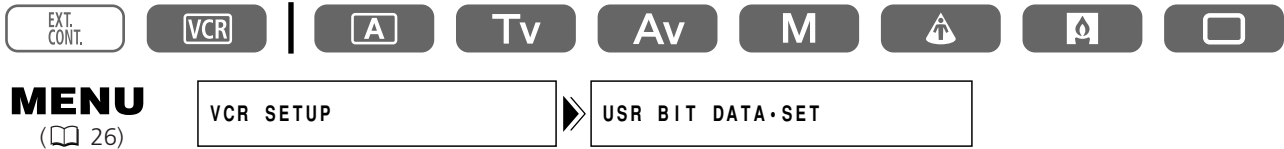

1. Open the menu and select [VCR SETUP] and [USR BIT DATA].

The user bit set/reset options appear.

2. Select [SET].

The first part of the display flashes.

3. Turn the SET dial to select the number/alphabet and press the SET dial.

- The next part of the display starts flashing.
- Set the rest of the display in the same way.

4. Close the menu.



- To reset the user bit to [00 00 00 00], select [CLEAR] in step 2.
- User bit can be recorded when recording with the camcorder or from analog devices. The user bit of your camcorder cannot be recorded when recording from digital devices.

Displaying the User Bit

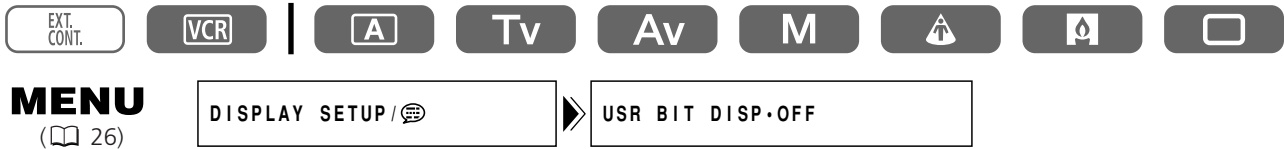

Open the menu and select [DISPLAY SETUP/ [speech bubble icon]]. Select [USR BIT DISP], set it to [ON] and close the menu.



User bit cannot be displayed during special playback.

Audio Recording

You can set the audio mode to 16 bit or 12 bit. With 12 bit, you can select to record on two channels, leaving two channels free for adding sound later (12bit CH $\frac{1}{2}$), or to record on four channels simultaneously (12bit CH $\frac{1}{2}$, $\frac{3}{4}$).

The sampling frequency in 16 bit is 48 kHz and in 12 bit 32 kHz. The 16 bit mode provides higher sound quality.

Audio dubbing cannot be performed with this camcorder.

16bit

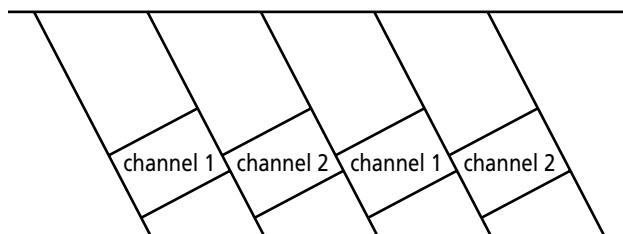

12bit CH $\frac{1}{2}$

The channels next to channel 1 and 2 will not be used.

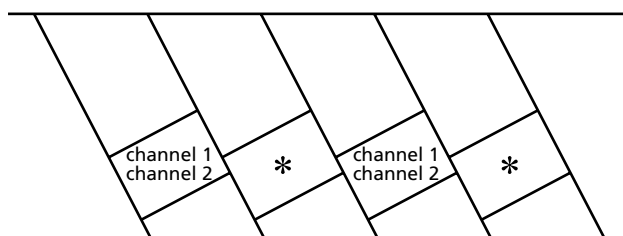

12bit CH $\frac{1}{2}$, $\frac{3}{4}$

The channels 1, 2, 3 and 4 will be recorded simultaneously.

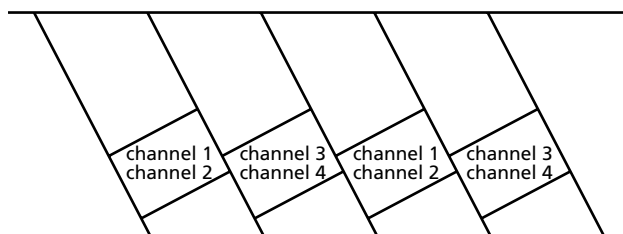

Selecting the Audio Mode (16bit, 12bit CH $\frac{1}{2}$, 12bit CH $\frac{1}{2}$, $\frac{3}{4}$)



Open the menu and select [AUDIO SETUP]. Select [AUDIO MODE], select a setting option and close the menu.

Recording on Channels 1 and 2

Select the audio input from FRONT MIC (supplied microphone unit), AUDIO1 (RCA terminals) or REAR (XLR terminals). Refer also to the audio block diagram (122).

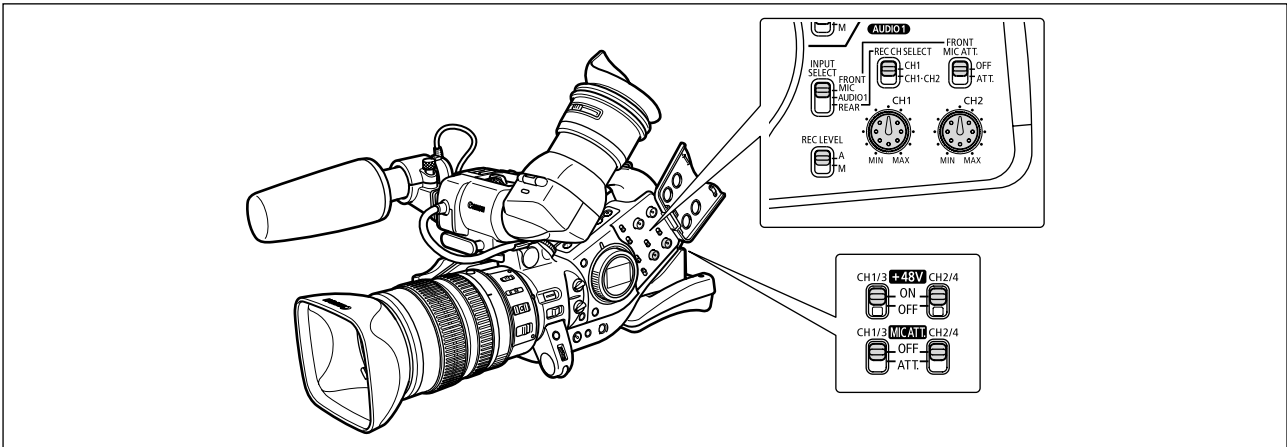

When Using the Front Microphone

Set the INPUT SELECT switch to FRONT MIC.

Turn on the microphone attenuator (20 dB) as necessary by setting the FRONT MIC ATT. switch to ATT.

When Connecting to the RCA terminals of AUDIO1 (Line-in Recording)

1. Connect the device to the RCA terminals of AUDIO1.
2. Set the INPUT SELECT switch to AUDIO1.

When Connecting to the XLR terminals

1. Connect a microphone to the XLR terminals.

To supply a microphone with phantom power, set the +48V switch to ON. Make sure to connect the microphone first, before turning on the phantom power. Keep the microphone connected when turning off the phantom power.

2. Set the INPUT SELECT switch to REAR.
3. Set the REC CH SELECT switch to CH1 or CH1-CH2.

Input terminal	Position of the REC CH SELECT switch	Recorded channel
CH1/3	CH1	Channel 1
	CH1-CH2	Channel 1+Channel 2
CH2/4	CH1	Channel 2
	CH1-CH2	---

4. Turn on the microphone attenuator (20 dB) as necessary by setting the MIC ATT. switch to ATT.
5. For 12dB gain-up: Open the menu and select [AUDIO SETUP]. Select [R-XLR GAINUP], set it to [12dB] and close the menu.



When connecting a microphone not supporting phantom power, make sure to set the +48V switch to OFF. Otherwise the microphone may be damaged.

Recording on Channels 3 and 4

Select the audio input from SHOE (optional MA-300 Microphone Adapter), AUDIO2 (RCA terminals) or REAR (XLR terminals). Refer also to the audio block diagram (122).

Make sure to set [AUDIO MODE] to [12bit CH 1/2, 3/4].

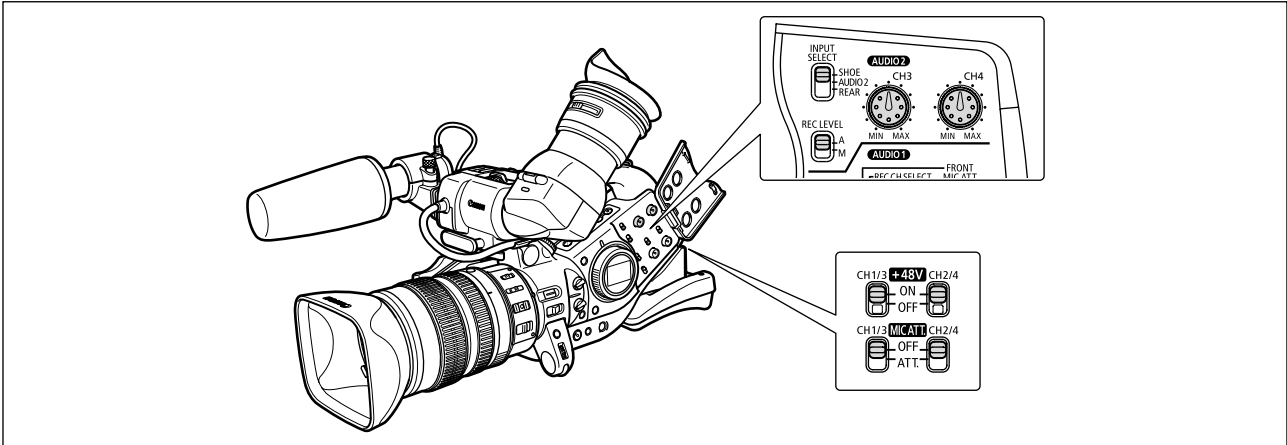

When Connecting to the Advanced Accessory Shoe

1. Attach the optional MA-300 Microphone Adapter to the advanced accessory shoe.

- With the MA-300, you can use balanced microphones on all 4 channels.
- Refer also to the MA-300 instruction manual.

2. Set the INPUT SELECT switch to SHOE.



- Phantom power cannot be used with the MA-300.
- MA-100 and MA-200 cannot be used.

When Connecting to the RCA terminals of AUDIO2 (Line-in Recording)

1. Connect the device to the RCA terminals of AUDIO2.

2. Set the INPUT SELECT switch to AUDIO2.

When Connecting to the XLR terminals

1. Connect a microphone to the XLR terminals.

To supply a microphone with phantom power, set the +48V switch to ON. Make sure to connect the microphone first, before turning on the phantom power. Keep the microphone connected when turning off the phantom power.

2. Set the INPUT SELECT switch to REAR.

3. Turn on the microphone attenuator (20 dB) as necessary by setting the MIC ATT. switch to ATT.

4. For 12 dB gain-up: Open the menu and select [AUDIO SETUP]. Select [R-XLR GAINUP], set it to [12dB] and close the menu.



When connecting a microphone not supporting phantom power, make sure to set the +48V switch to OFF. Otherwise the microphone may be damaged.

Adjusting the Audio Recording Level

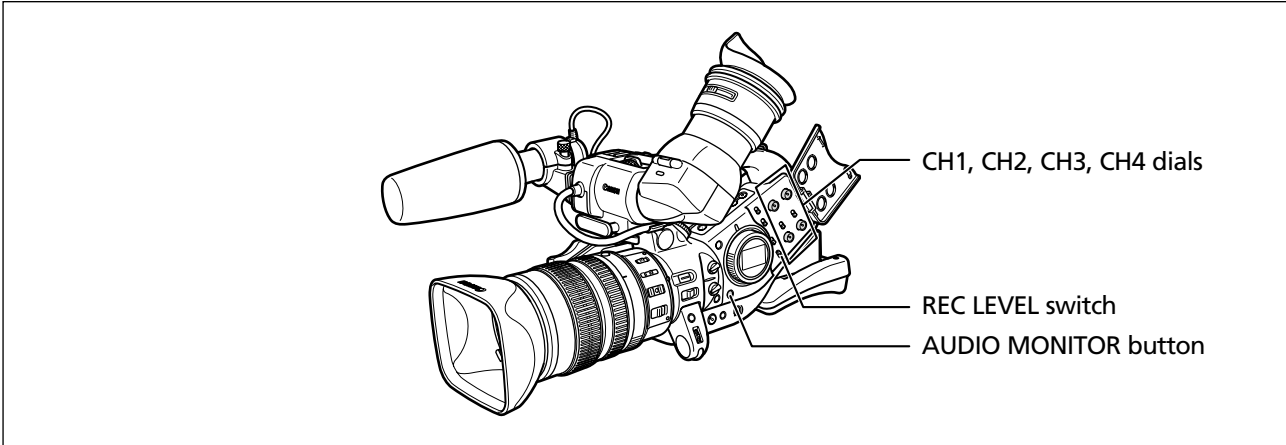

Hiding/Displaying the Audio Level Indicator on the Screen

MENU
(26)



Open the menu and select [DISPLAY SETUP/]. Select [AUDIO LEVEL], select a setting option and close the menu.

The audio level indicator can also be turned on/off with the custom key (74).

Automatic Audio Adjustments

Set the REC LEVEL switch to A.

Manual Audio Adjustments

1. Set the REC LEVEL switch to M.
2. When recording on 4 channels, press the AUDIO MONITOR button and select CH1/2 or CH3/4.
The setting changes with each press of the button in the order of CH1/2, CH3/4, CH1+3/2+4. Do not select CH1+3/2+4 when adjusting the level.
3. Turn the respective CH1, CH2, CH3 or CH4 dial to adjust the audio level.



- We recommend using headphones when adjusting the audio level. If the input level is too high, audio may become distorted even if the audio level indicator is displaying an appropriate level.
- You can select to synchronize the audio signal with the video signal by adding an equal amount of delay to the audio. Open the menu and select [AUDIO SETUP]. Select [AUD.M.SET], set it to [LINE OUT] and close the menu. If you wish to monitor audio in real time, select [NORMAL]. In either setting, audio and video signals will be recorded synchronized on a tape.

Image Stabilizer (Lenses Equipped with Image Stabilizer)

The image stabilizer can be turned off.

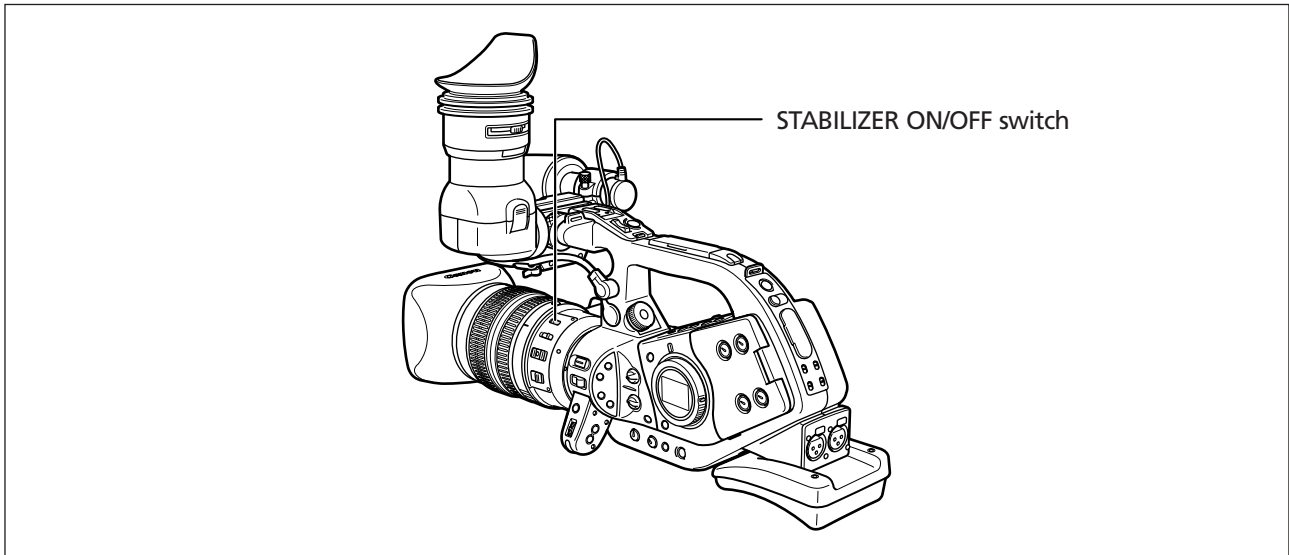

Move the STABILIZER ON/OFF switch to OFF.



- The image stabilizer cannot be turned off in the Easy Recording mode.
- The image stabilizer is designed to compensate a normal degree of camcorder shake.
- The image stabilizer may not be effective when attaching an optional Extender.
- We recommend turning off the image stabilizer when mounting the camcorder on a tripod.

Using the Programmed AE Modes

Programmed auto exposure modes provide automated advanced recording techniques ensuring professional results in various shooting conditions.

E

Selecting the Programmed AE Modes

Press the button and turn the POWER dial.

The symbol of the selected mode appears.

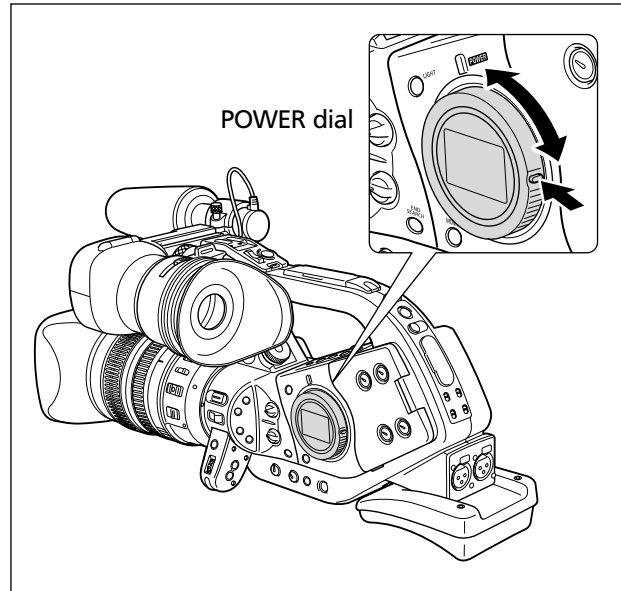

Do not change the mode during recording as the brightness of the image may change abruptly.

A Auto

Like the Easy Recording mode, the camcorder automatically controls camera adjustments allowing you to simply point and shoot. However, in the Auto mode, you have the option of adjusting the settings manually.



Tv Shutter-Priority (58)

Use this mode to select the shutter speed. The camcorder automatically sets a matching aperture setting.



Av Aperture-Priority (59)

Use this mode to select between 7 aperture settings - from f/1.6 to f/11 (or to full iris close) - and the camcorder automatically sets a matching shutter speed. This mode allows for the best control of depth of field.



Recording

M Manual (📖 60)

This mode offers the creative freedom of a complete range of manual controls. In the Manual mode, options exist to set the exposure at any combination of shutter speed and aperture levels.



🔦 Spotlight

The Spotlight mode automatically adjusts the exposure to effectively record images and/or subjects lit by a spotlight or other concentrated light source.



🔥 Low Light (60i/30p)

This mode allows you to continue recording even when light levels begin to fall. The Low Light mode selects lower shutter speeds (60i: 1/8-1/59, 30p: 1/8-1/29) to deliver proper exposure.

Slow shutter speeds are not available in 24p mode. The shutter speeds will be the same as in the Easy Recording mode.

- Moving subjects may leave a trailing afterimage.
- Picture quality may not be as good as in other modes.
- White points may appear on the screen.
- Autofocus may not work as well as in other modes. In such case, adjust the focus manually.



☐ Easy Recording

The camcorder automatically controls focus, shutter speed, aperture, gain, white balance, and AE Shift allowing you to simply point and shoot. This mode locks all of these features and options, making them fixed and unadjustable.

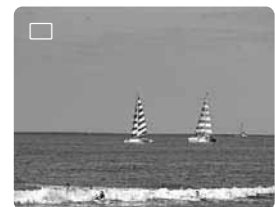

Availability of functions in each recording program.

Recording programs							
EXP. LOCK button	×		○		×	×	×
IRIS dial	×	× *1	× *1	○	○	×	×
SHUTTER button	×	× *1	○	× *1	○	×	×
AE SHIFT dial	× (0)		○ *2		×	×	× (0)
GAIN dial	× (auto)		○			× (0 dB)	× (auto)
WHITE BALANCE dial	× (auto)				○		
Custom preset adjustments	×				○		
CUSTOM PRESET SELECT button	×				○		
CUSTOM PRESET ON/OFF button	×				○		
Skin detail	×				○		
Frequency selection of Clear Scan	×	×	○ *3	×	○ *3	×	×
Clear Scan	×	×	○ *2	×	○	×	×

○: Available ×: Not available

*1: Available when the exposure is locked.

*2: Not available when exposure is locked.

*3: Available during clear scan.

20× L IS, 16× IS II and 3× zoom lens

Recording program		Modes other than
Manual focus ring		○
Zoom ring		○
Image Stabilizer*	× (on)	○
ND filter		○
Focus mode	× (autofocus)	○
▶AF switch/PUSH AF button	×	○

* Not available with the 3× zoom lens.

Recording in the Shutter-Priority (Tv) Mode

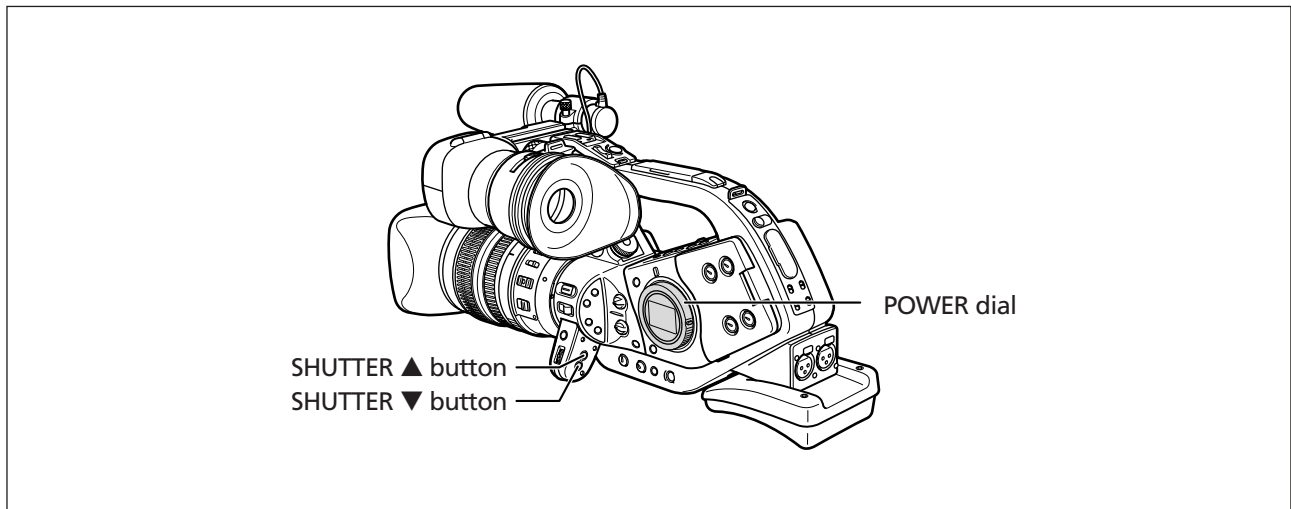







Available shutter speeds depend on the selected frame rate.

60i/30p	1/8, 1/15, 1/30, 1/60, 1/100, 1/250, 1/500, 1/1000, 1/2000, 1/4000, 1/8000, 1/15000, CS (clear scan)
24p	1/24, 1/48, 1/60, 1/100, 1/250, 1/500, 1/1000, 1/2000, 1/4000, 1/8000, 1/15000, CS (clear scan)



1. Set the POWER dial to Tv.
2. Select the shutter speed with the SHUTTER ▲ or ▼ button.

-  Other settings such as aperture are set automatically.
-  The shutter speed changes when you lock and change the exposure.
-  When the gain is set to automatic, the shutter speed number flashes on the screen when the selected shutter speed is too high or too low for the recording condition. In such case, readjust the shutter speed. If you are using a ND filter, turn it off first and readjust the shutter speed.
-  The image quality may decrease to some extent when using slow shutter speeds.
-  Autofocus may not work when using slow shutter speeds.
-  When recording under artificial light sources such as fluorescent, mercury or halogen lamps, the screen may flicker depending on the shutter speed. To avoid the flicker, set the shutter speed to 1/100.

Recording in the Aperture-Priority (Av) Mode

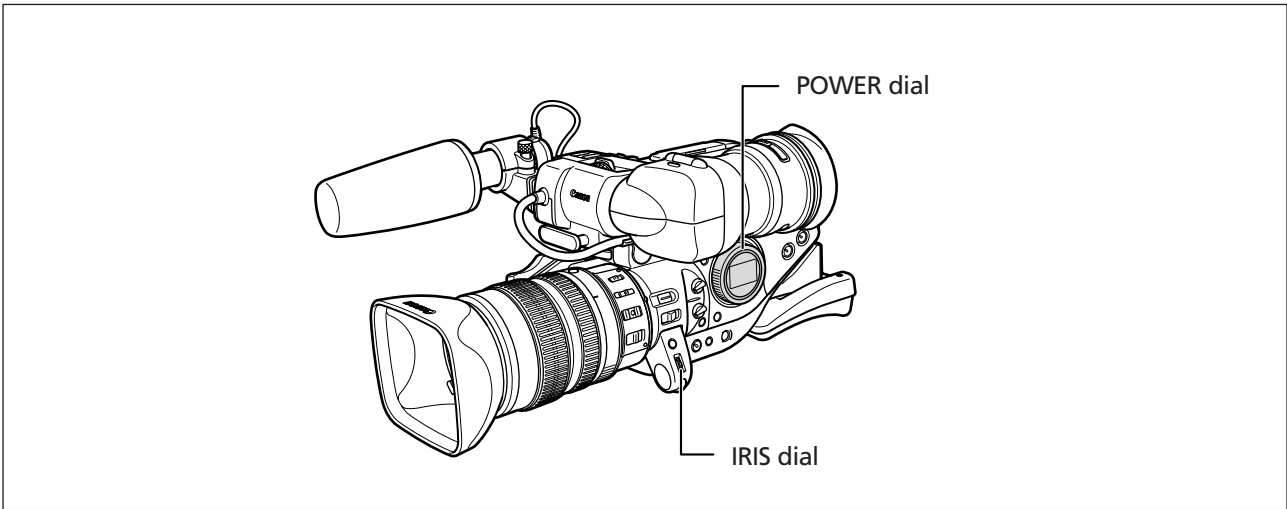

E

Available aperture values (with 20× L IS lens)

F1.6, F2.0, F2.8, F4.0, F5.6, F8.0, F11, CLOSE



1. Set the POWER dial to **Av**.
2. Select the aperture with the IRIS dial.



- Other settings such as shutter speed are set automatically.
- The aperture changes when you lock and change the exposure.
- When the gain is set to automatic, the aperture number flashes on the screen when the selected aperture is not appropriate for the recording condition. In such case, readjust the aperture.
- When the built-in ND filter of a lens is activated, the picture may become dark when you set a high F number. In such case, turn the ND Filter off first and readjust the aperture.

Recording

Recording in the Manual Mode

You can set the exposure at any combination of shutter speed and aperture levels.

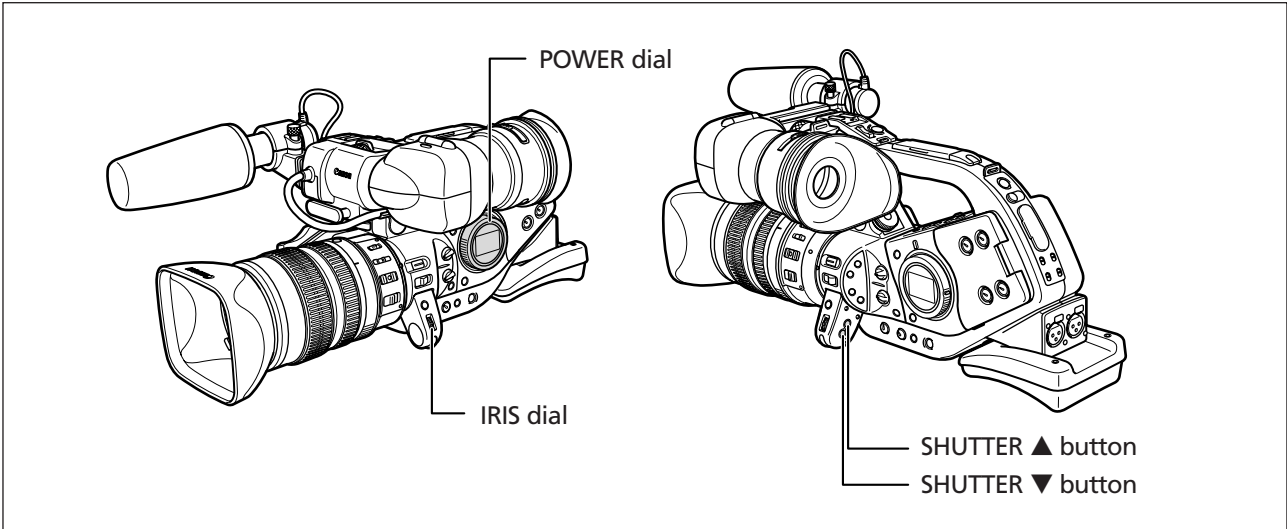

Available settings

Shutter speed	60i/30p	1/8, 1/15, 1/30, 1/60, 1/75, 1/90, 1/100, 1/120, 1/150, 1/180, 1/210, 1/250, 1/300, 1/360, 1/420, 1/500, 1/600, 1/720, 1/840, 1/1000, 1/1200, 1/1400, 1/1700, 1/2000, 1/2300, 1/2600, 1/3000, 1/4000, 1/8000, 1/15000, CS (clear scan)
	24p	1/24, 1/48, 1/60, 1/75, 1/90, 1/100, 1/120, 1/150, 1/180, 1/210, 1/250, 1/300, 1/360, 1/420, 1/500, 1/600, 1/720, 1/840, 1/1000, 1/1200, 1/1400, 1/1700, 1/2000, 1/2300, 1/2600, 1/3000, 1/4000, 1/8000, 1/15000, CS (clear scan)
Aperture (with 20× L IS lens)		F1.6, F1.8, F2.0, F2.2, F2.4, F2.6, F2.8, F3.2, F3.4, F3.7, F4.0, F4.4, F4.8, F5.2, F5.6, F6.2, F6.7, F7.3, F8.0, F8.7, F9.5, F10, F11, CLOSE



1. Set the POWER dial to M.

The exposure indicator appears.

2. Select the aperture with the IRIS dial.

3. Select the shutter speed with the SHUTTER ▲ or ▼ button.

Adjusting the Exposure

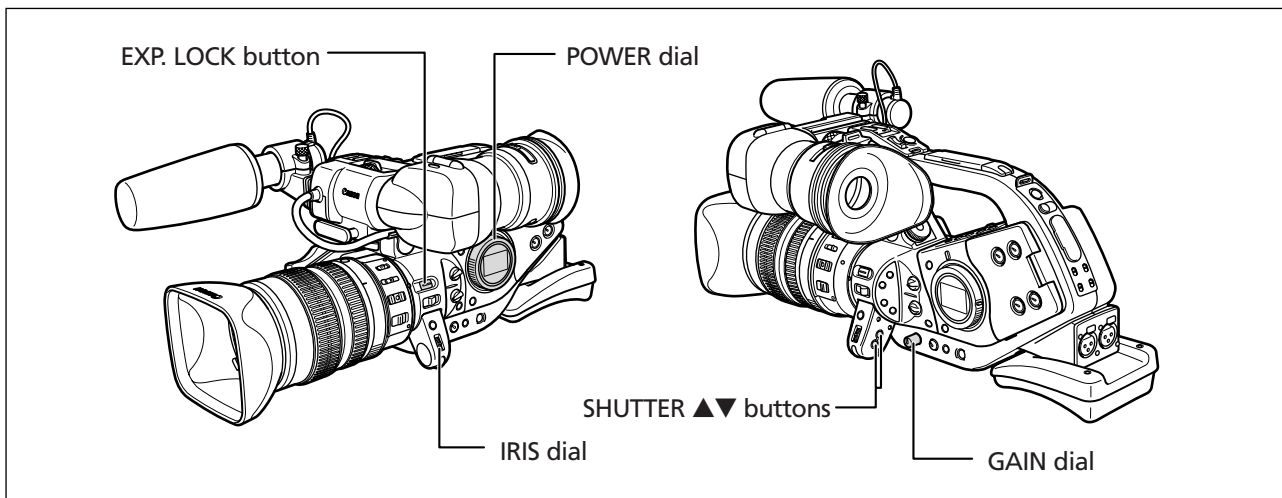

Exposure Lock



1. Set the POWER dial to **A**, **Tv** or **Av**.
2. Press the **EXP. LOCK** button.
The exposure indicator appears.

Changing the Aperture after Exposure Lock

You can select from 23 aperture settings (with 20× L IS lens). The setting can be adjusted in 1/4 steps. However, only the following numbers are displayed on the screen: F1.6, F2.0, F2.8, F4.0, F5.6, F8.0, F11, CLOSE.

Select the aperture with the **IRIS** dial.

Changing the Shutter Speed after Exposure Lock

You can select from 12 shutter speeds (with 20× L IS lens).

Select the shutter speed with the **SHUTTER ▲** or **▼** button.

Changing the Gain after Exposure Lock

You can select from 6 gain levels .

1. Press the **GAIN** dial so that it pops out.
2. Turn the **GAIN** dial to adjust the level.
The selected level appears.

 +18 dB is not available in 30p and 24p mode. When you select +18 dB, it automatically sets to +12 dB ("12dB" appears in yellow).

Using AE Shift

You can use the AE Shift control to manually override the automatic exposure system to darken or lighten the image. Select from 13 AE levels (+2.0, +1.5, +1.0, +0.75, +0.5, +0.25, ± 0 , -0.25, -0.5, -0.75, -1.0, -1.5, -2.0).

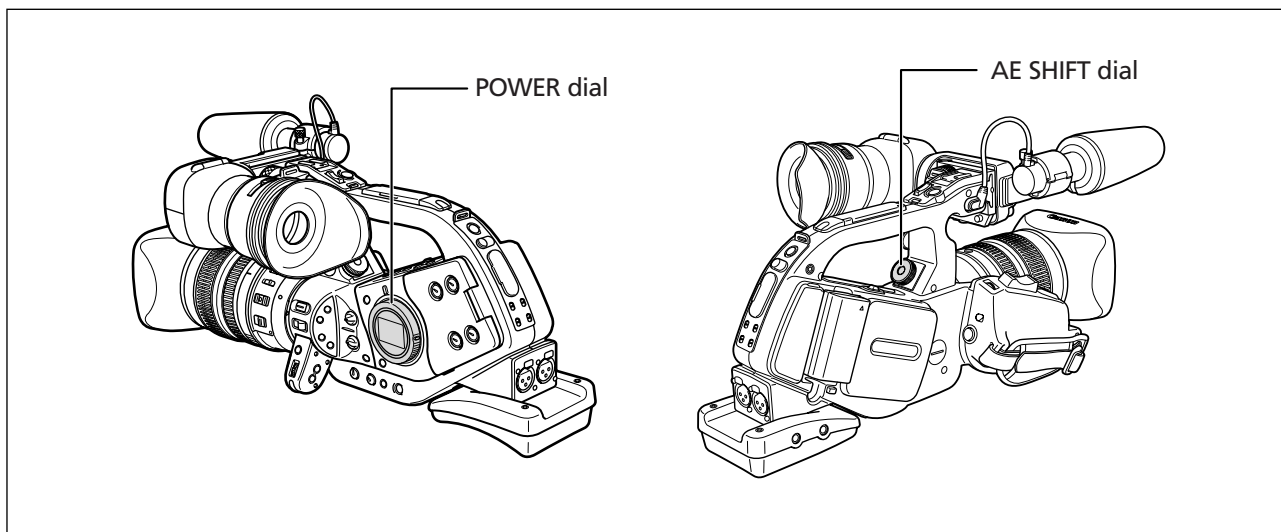

1. Set the POWER dial to **A**, **Tv** or **Av**.
2. Turn the AE SHIFT dial to adjust the level.
The selected level appears.

Adjusting the Gain

Gain control adjusts the amount of video signal generated depending upon lighting and shooting conditions. You can select from automatic gain control and preset levels that range from -3 to +18 dB.

-3 dB	For lowest noise recording for indoor, low light or low contrast scenes.
Auto	Automatic adjustment of gain.
0 dB	Life like night/artificial light scenes.
+3 dB/+6 dB/ +12 dB/+18 dB*	Increases brightness in indoor or low-light scenes. Increases depth of field.

* +18 dB is not available in 30p and 24p mode. When you select +18 dB, it automatically sets to +12 dB ("12dB" appears in yellow).

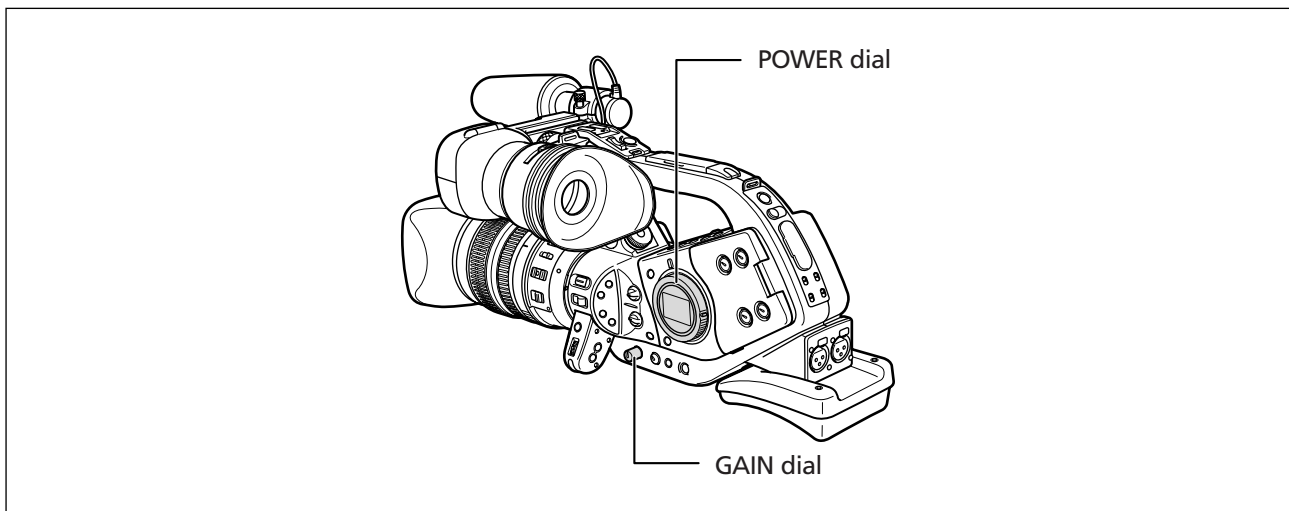

1. Set the POWER dial to **A**, **Tv**, **Av** or **M**.
2. Press the GAIN dial so that it pops out.
3. Turn the GAIN dial to adjust the level.

The selected level appears.



Noise may appear on the picture when setting a high gain level.

Setting the White Balance

The camcorder uses an electronic white balance process to calibrate the picture for accurate color display in different lighting conditions (i.e. sunlight versus indoor incandescent.)

Automated white balance settings include a fully automated mode, an indoor mode and an outdoor mode. In addition, you can set the white balance manually and save up to three white balance presets that can be reused for non-sequential shooting.

Auto	Automated adjustments of white balance.
☀ (Outdoor)	Bright sunlight - 5600°K
💡 (Indoor)	Incandescent light - 3200°K
Preset 1, 2, 3	Custom white balance setting variable 3200 - 5600°K.

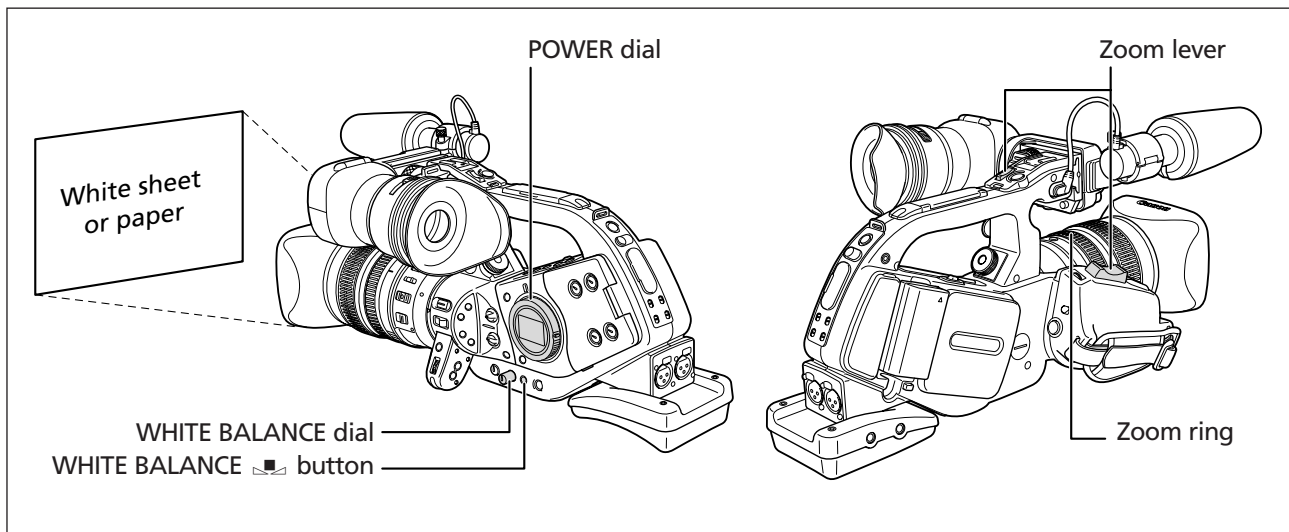



Selecting an Automated White Balance Setting



1. Press the **WHITE BALANCE** dial so that it pops out.
2. Set the **WHITE BALANCE** dial to **A**, ☀ or 💡.

Setting a Custom White Balance



1. Press the **WHITE BALANCE** dial so that it pops out.
2. Set the **WHITE BALANCE** dial to 1, 2 or 3.
3. Point the camcorder at a white object and zoom in until it fills the whole screen.
Keep the camcorder zoomed at the white object until step 4 is completed.
4. Press the **WHITE BALANCE**  button.
"  " flashes and stops flashing when setting is complete.



- The camcorder retains the custom white balance setting even if you turn it off.
- When you have set the custom white balance:
 - Depending on the light source, "  " may keep flashing. The result will still be better than with the auto setting.
 - When you have turned on/off the built-in ND-filter of the lens, reset the custom white balance.
- Custom white balance may provide better results in the following cases:
 - Changing lighting conditions
 - Close-ups
 - Subjects in a single color (sky, sea or forest)
 - Under mercury lamps or certain types of fluorescent lights

Recording with Preset Custom White Balance



1. Set the **POWER** dial to a recording program other than .
2. Turn the **WHITE BALANCE** dial to select a preset number.
The preset custom white balance is activated.



- The custom preset settings [R GAIN], [G GAIN] and [B GAIN] ( 69) will override the white balance setting set with above procedure.

Using the Zebra Pattern

This camcorder has a zebra pattern feature that shows black and white diagonal stripes over the area that is overexposed. The zebra pattern is only displayed on the screen. Use this feature to guide the adjustment of the aperture and shutter speed. Available zebra pattern settings: 80 IRE, 85 IRE, 90 IRE, 95 IRE, and 100 IRE.

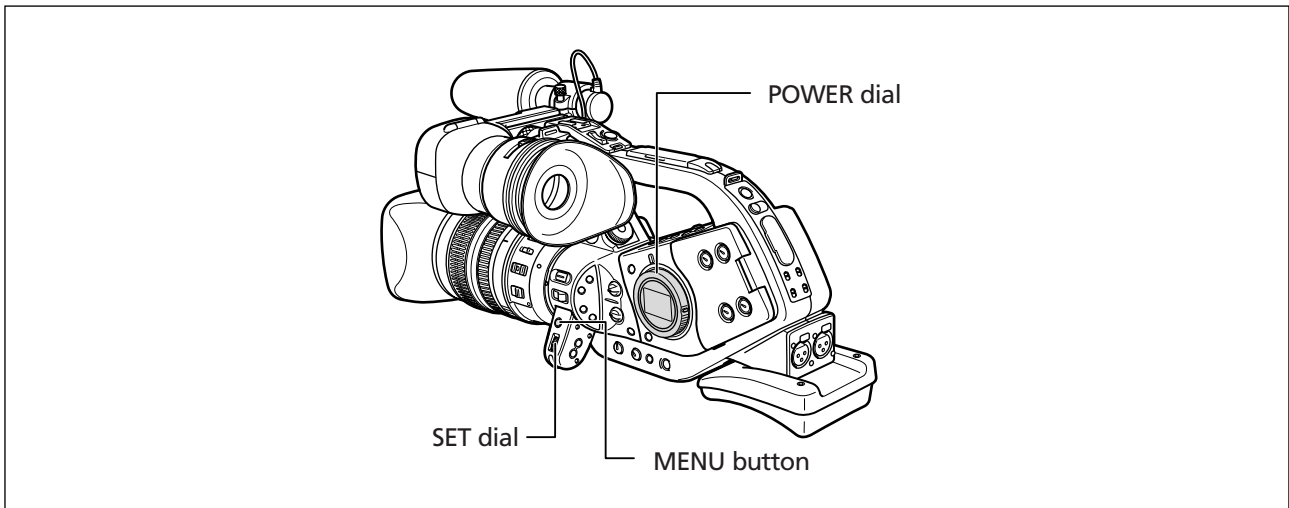

Selecting the Zebra Pattern Level

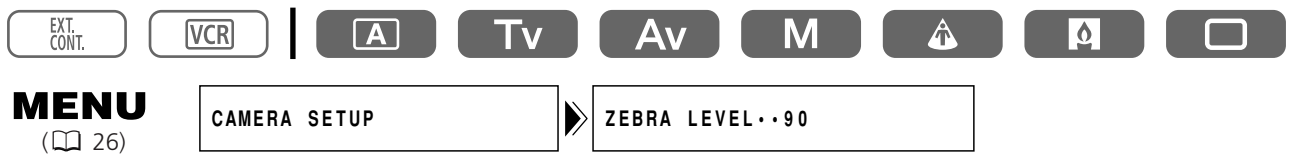

Open the menu and select [CAMERA SETUP]. Select [ZEBRA LEVEL], select a setting option and close the menu.

Activating the Zebra Pattern

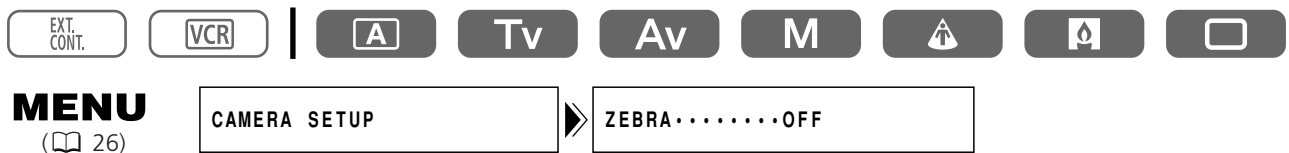

Open the menu and select [CAMERA SETUP]. Select [ZEBRA], set it to [ON] and close the menu.

Using the Skin Detail Function

You can adjust hue, chroma, area and Y level to determine the skin area and soften the details to reduce the appearance of skin imperfections. A zebra pattern identifying the skin area appears, alternating with the normal picture (a white pattern appears on a connected TV or computer screen).

E

Activating the Skin Detail Function



Open the menu and select [CAMERA SETUP] and [SKIN D.SET]. Select [SKIN DETAIL], set it to [HIGH , [MIDDLE ] or [LOW ] and close the menu.

"" appears.

Determining the Skin Area

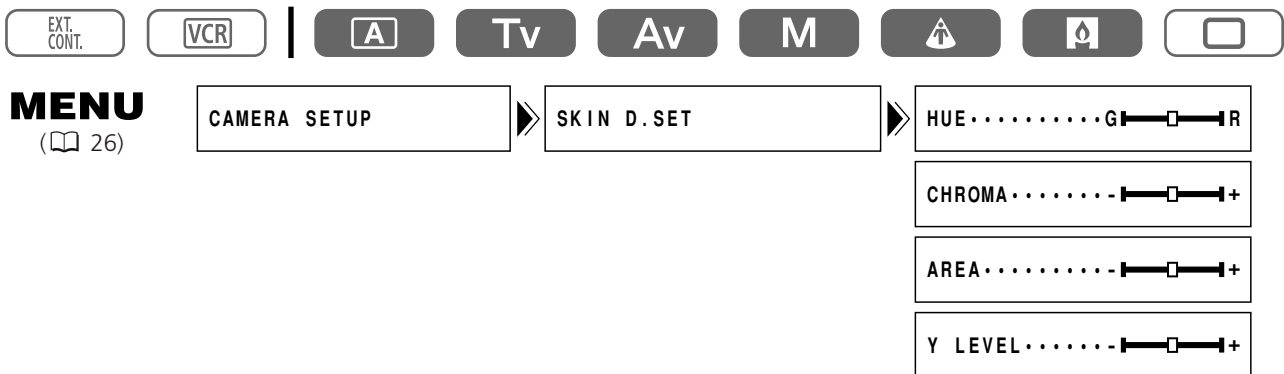

Open the menu and select [CAMERA SETUP] and [SKIN D.SET]. Select [HUE], [CHROMA], [AREA] or [Y LEVEL], adjust the levels and close the menu.

- HUE: Adjust the hue for detection of the skin area. Adjusting to [R] detects reddish skin color, and to [G] detects greenish skin color.
- CHROMA: Adjust the saturation for detection of the skin area. Adjusting to [+] detects brighter skin color, and to [-] detects lighter skin color.
- AREA: Adjust the color range for detection of the skin area. Adjusting to [+] detects a wide color range, and to [-] detects a narrow color range.
- Y LEVEL: Adjust the brightness for detection of the skin area. Adjusting to [+] detects brighter skin color, and to [-] detects darker skin color.



You cannot record on the tape while determining the skin area.

Recording

Using the Custom Preset

You can establish three preset registrations for the following 15 camera features: gamma curve, knee, black stretch/press, color matrix, color gain, color phase, R gain, G gain, B gain, V detail, sharpness, coring, setup level, master pedestal and NR.

You can also import preset settings from another XL2 and save them to your camcorder.

Gamma Curve

Select between standard gamma curve ([NORMAL]) and cine-like gamma curve ([CINE]).

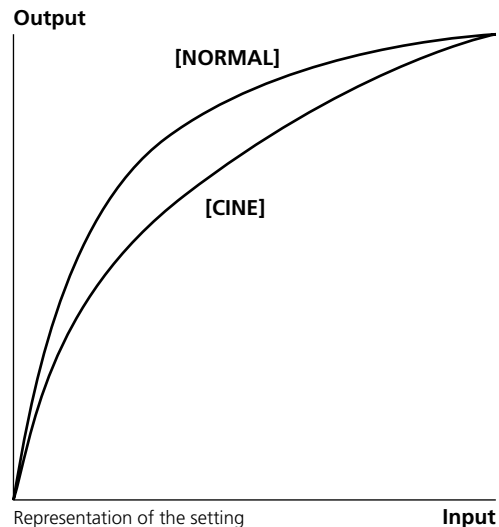

Knee Point Adjustment

Adjust the dynamic range (knee point) in the highlight area of the image to prevent overexposure. You can select from [HIGH], [MIDDLE] or [LOW].

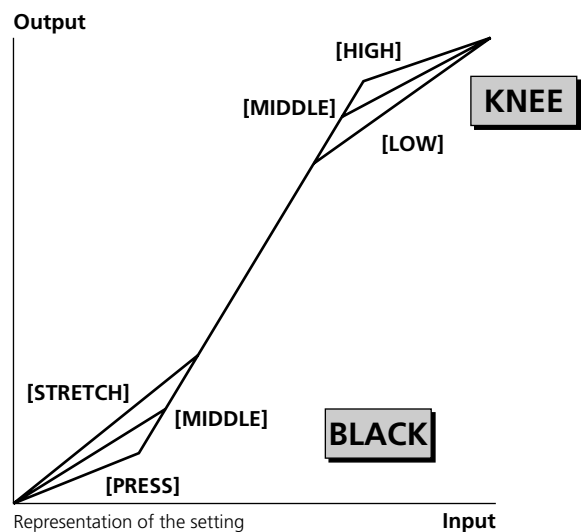

Black Stretch/Black Press

Adjust the dynamic range in the black area of the image. You can select from [STRETCH], [MIDDLE] or [PRESS]. [STRETCH] emphasizes contrast in the dark area, while [PRESS] enhances or deepens darkness.

Color Matrix

Select from two color matrix settings: [NORMAL] and [CINE]. Setting gamma and color matrix to [CINE] creates cine-like colors.

Color Gain

Adjust the saturation of the color from off (-) to oversaturated (+).

Color Phase

Adjust to [G] for adding more green to the image, and to [R] for more red.

R Gain

Adjust to [-] for white balance toward cyan, and to [+] for white balance toward red.

G Gain

Adjust to [-] for white balance toward magenta, and to [+] for white balance toward green.

B Gain

Adjust to [-] for white balance toward yellow, and to [+] for white balance toward blue.

Vertical Detail

Adjust the vertical detail frequency for recordings in 30p or 24p mode. Select from [NORMAL] and [LOW].

- When you play back a recording on an interlaced TV with [V DETAIL] set to [NORMAL], horizontal lines may flicker.
- Select [NORMAL] for non-interlaced playback or editing on a computer, or for transferring to a DVD.
- Image resolution will not change in the 60i mode.
- When you select a custom preset setting with [V DETAIL] set to [LOW] in 60i mode, "CP" appears in yellow.

Sharpness

Adjust the degree of sharpness in the picture. Adjust to [-] for a softer picture, and to [+] for a sharper picture. When set to the [+] side, noise may become more noticeable.

Coring

Adjust the detail noise level. Adjust to [-] to add the noise, and to [+] to reduce noise.

Setup Level

Adjust the black level of the video signal. Adjust to [-] to darken the picture, and to [+] to brighten the shadow area.

Master Pedestal

Adjust the master pedestal level. Adjust to [-] to make dark areas darker and increase the contrast, and to [+] to make dark areas lighter and reduce the contrast.

Noise Reduction

Select the variable range of noise reduction from [OFF], [HIGH], [MIDDLE] and [LOW]. With [HIGH], [MIDDLE] and [LOW], the noise reduction level is adjusted according to the gain. Select [HIGH] for maximum variable range.

- When set to [HIGH], moving subjects may leave a trailing afterimage.
- When the noise based on the gain setting is low, the NR effect may not be noticeable.

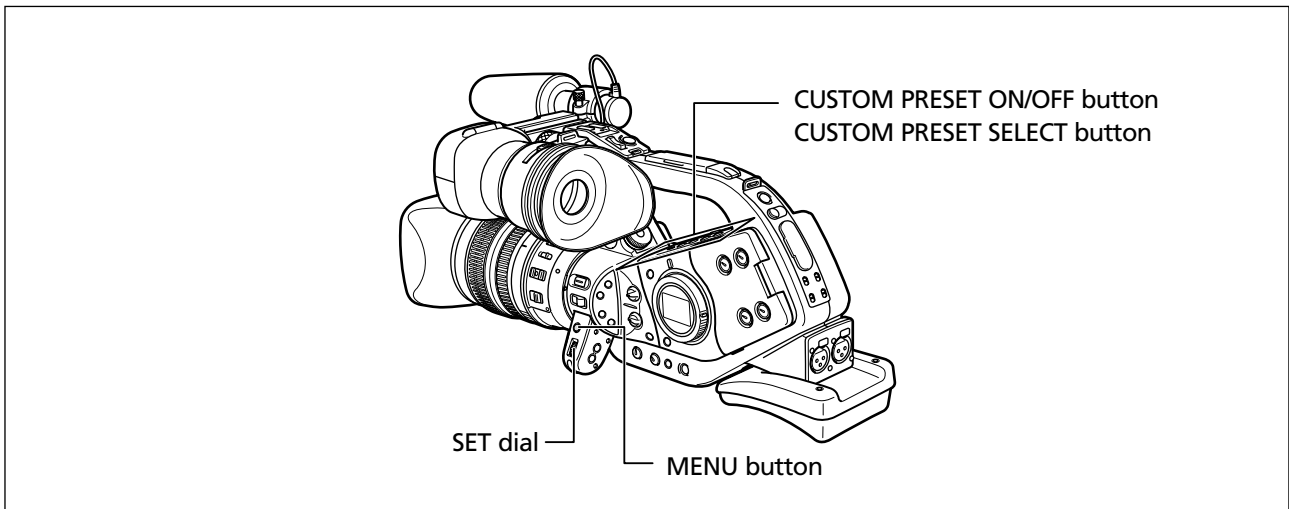

Setting the Custom Preset Settings



1. Open the menu and select [CUSTOM PRESET].
2. Select [PRESET SETUP].
The custom preset items appear.
3. Select [SEL PRESET] and select the custom preset file you wish to change.
4. Select the preset items, select the setting options and close the menu.

-  ○ The custom preset menu consists of 5 pages. The items [SEL PRESET] and [ON/CLEAR] can be selected on each page.
- When you attempt to change a protected setting, "ON" starts flashing.

Protecting a Custom Preset File

Open the menu and select [CUSTOM PRESET], followed by [PRESET SETUP]. Select [ON/CLEAR], set it to [PROTECT ON] and close the menu.

To cancel the protection, reselect [PROTECT ON].

Resetting a Custom Preset File

1. Open the menu and select [CUSTOM PRESET], followed by [PRESET SETUP].
2. Select [ON/CLEAR] and set it to [CLEAR].
A confirmation message appears.
3. Select [Yes] and close the menu.

-  A protected preset file cannot be reset.

Activating the Custom Preset Settings



1. Press the CUSTOM PRESET SELECT button.

- The setting changes with each press of the button in the order of "CP1", "CP2", "CP3" and "CPOFF".
- When you are not using the custom preset setting, set the camcorder to "CPOFF".

2. Press the CUSTOM PRESET ON/OFF button.

The setting is activated.

Importing a Custom Preset Setting from Another XL2

You can import a custom preset setting from another XL2 and save it to your camcorder.

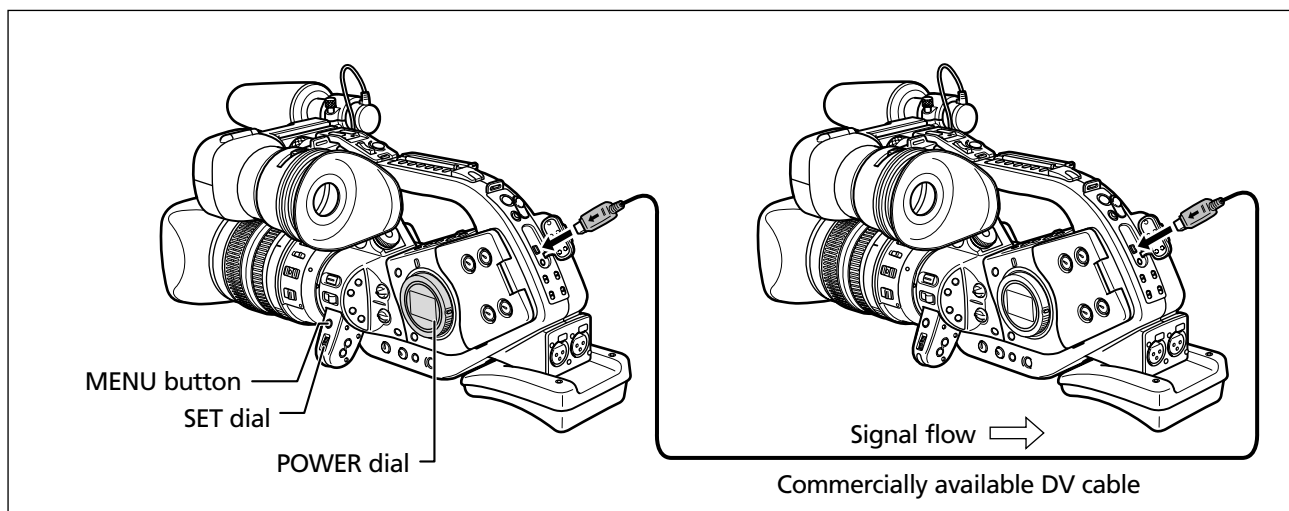

Preparations

1. Connect the camcorders with a DV cable.
2. XL2 from which you wish import: Set the POWER dial to EXT. CONT.
 XL2 to which you wish to import: Set the POWER dial to a recording program other than .

Importing (Operation on the XL2 to which you import)

1. Open the menu and select [CUSTOM PRESET] and [READ PRESET].

The IMPORT PRES. menu appears.

2. Select [SEL PRESET] and set it to the custom preset file you wish to import.

3. Select [SEL POSITION].

The SEL POSITION menu appears.

4. Select [SEL PRESET] and set it to the custom preset file you wish to overwrite.

5. Select [OVERWRITE].

A confirmation message appears.

6. Select [YES].

The custom preset file is imported.



Make sure that protection is canceled when saving a preset setting.



You can review but not change the preset settings of the connected XL2.

[READ PRESET] can only be selected when another XL2 is connected.

Using Clear Scan for Recording Computer Screens

This feature allows you to record computer CRT screen or other equipment without displaying black band or flicker on the screen. You can adjust the frequency from 60.0 Hz to 202.5 Hz.

E

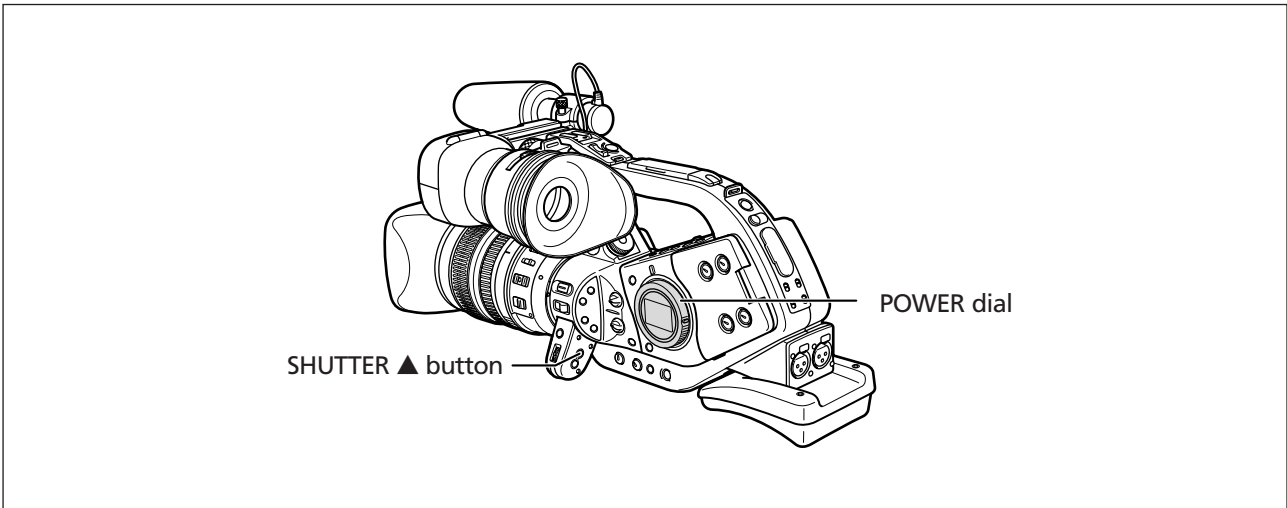

1. Set the POWER dial to **Tv** or **M**.
2. Press the SHUTTER ▲ button to display "CS".
3. Open the menu and select [CAMERA SETUP]. Select [CLEAR SCAN], adjust the frequency and close the menu.
Select a frequency with which the black band does not appear.

Recording

Using the Custom Keys

You can assign frequently used functions to the custom keys (for recording and VCR mode independently).

Default settings:

	Recording Mode	VCR Mode
CUSTOM KEY 1	TIME CODE	TV SCREEN
CUSTOM KEY 2	INDEX WRITE	DATA CODE

Following functions can be assigned to the custom keys:

Recording Mode

Time code
Index write
Zebra pattern
VCR STOP*
TV screen
Handle zoom speed
Audio level indicator

VCR Mode

Time code
TV screen
Data code
Audio level indicator

* Function that can only be operated by the custom keys.



To check the current custom key settings:

In recording mode: Open the menu and select [DISPLAY SETUP/☰]. Select [GUIDE INFO], set it to [CUSTOM KEYS] and close the menu.

In VCR mode: Open the menu and select [DISPLAY SETUP/☰]. Select [CUSTOM KEYS], set it to [ON] and close the menu.

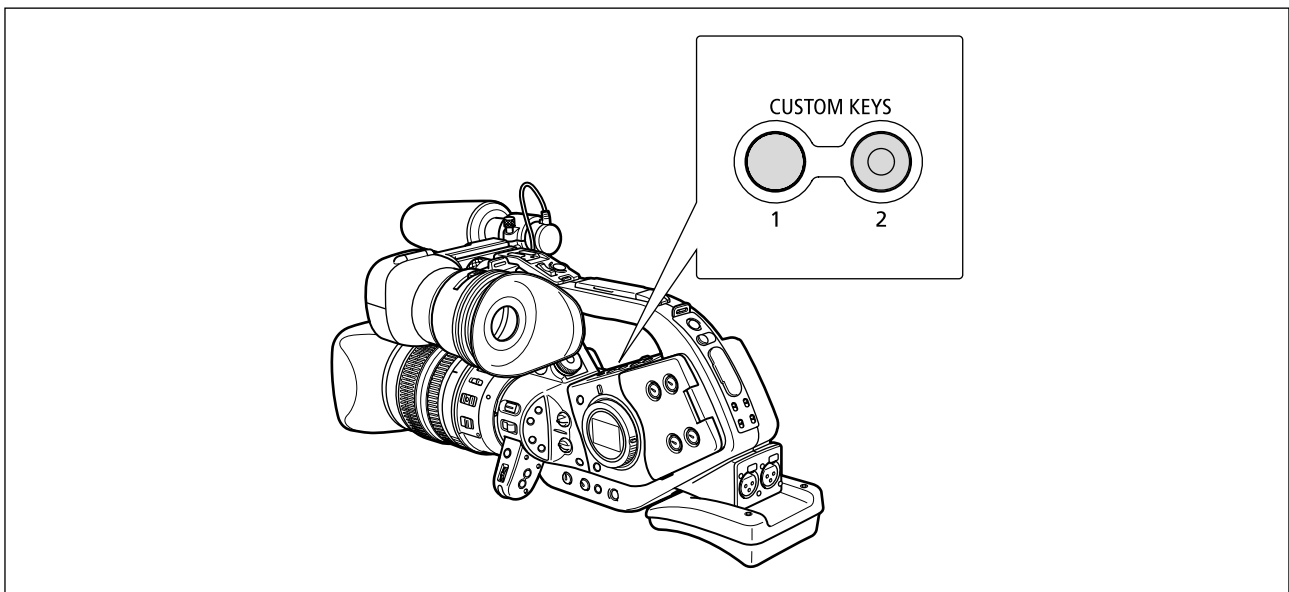

Changing the custom keys setting

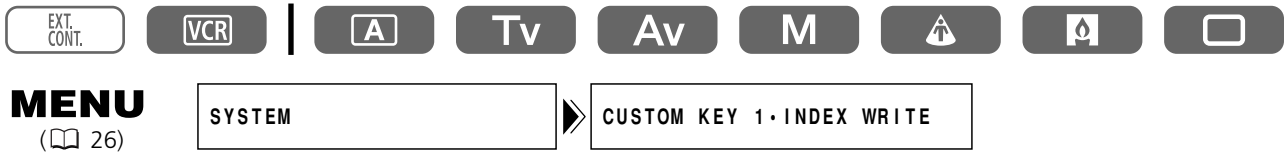

Open the menu and select [SYSTEM]. Select [CUSTOM KEY 1] or [CUSTOM KEY 2], select the function you wish to assign to the custom key and close the menu.

When you do not wish to use the custom keys, select [(NONE)].

Activating the Functions with the Custom Key

Time Code (47)



Press the CUSTOM KEY (1 or 2) button.

The time code setting menu appears.

Index Write

You can add an index signal to your recording for easy search in VCR mode.



Press the CUSTOM KEY (1 or 2) button.

- The index signal will be recorded for approx. 6 seconds.
- When the camcorder is in record pause mode, the index signal will be written when you start recording.



- An index signal cannot be added or erased later.
- Index write cannot be used during interval timer recording.

Zebra Pattern (66)



Press the CUSTOM KEY (1 or 2) button.

The zebra pattern is activated. Press the button again to deactivate it.

VCR STOP (📖 33)

In VCR STOP mode, the camcorder retains camera settings such as aperture and shutter speed, so you can adjust the camera section without worrying about the automatic shut-off.

VCR STOP can only be operated with the custom keys.



Press the CUSTOM KEY (1 or 2) button.

The VCR STOP mode is activated. Press the button again to return to record pause mode.

TV Screen (📖 104)

You can show the camcorder display on a connected TV.



Press the CUSTOM KEY (1 or 2) button.

Handle Zoom Speed (📖 38)



Press the CUSTOM KEY (1 or 2) button.

The ZOOM HANDLE menu appears. Select a setting option with the SET dial.

Audio Level Indicator (📖 53)



Press the CUSTOM KEY (1 or 2) button.

The audio level indicator appears. Press the button again to hide the audio level indicator.

Data Code (📖 93)



Press the CUSTOM KEY (1 or 2) button.

The data code appears. Press the button again to hide the data code.

Recording Color Bars/Audio Reference Signal

Color Bars

You can generate and record SMPTE (Society of Motion Picture and Television Engineers) color bars.

E

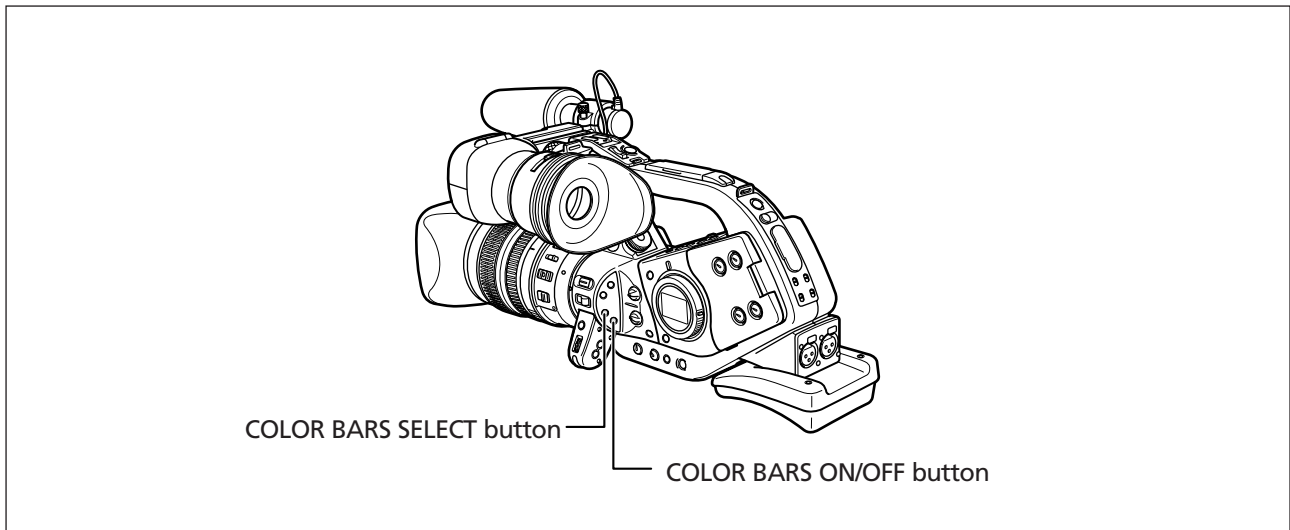

1. Press the COLOR BARS SELECT button to display "COLOR BARS".

The setting changes with each press of the button. "COLOR BARS" flashes.

2. Press the COLOR BARS ON/OFF button.

"COLOR BARS" stops flashing, and the color bars appear. Press the button again to deactivate the color bars.

Recording

Audio Reference Signal

You can record a 1 kHz audio reference signal (-12 dB or -20 dB) along with the color bars.



MENU

(26)

AUDIO SETUP



1kHz TONE...OFF

Open the menu and select [AUDIO SETUP]. Select [1kHz TONE], select the audio signal and close the menu.

The selected audio reference signal sounds.

Recording with the Interval Timer

With the interval timer, you can record images over a selected time with a selected interval. This function is useful when shooting flowers, animals, and other natural events.

You can choose an interval from 30 seconds, 1 minute, 5 minutes and 10 minutes, and a recording time from 0.5 seconds, 1 second, 1.5 seconds, and 2 seconds.

Example: 2 seconds recording time at a 5 minutes interval

(= standby time of 5 minutes including the recording time of 2 seconds)

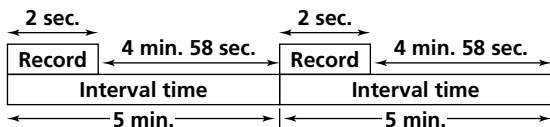

Selecting Interval and Recording Time

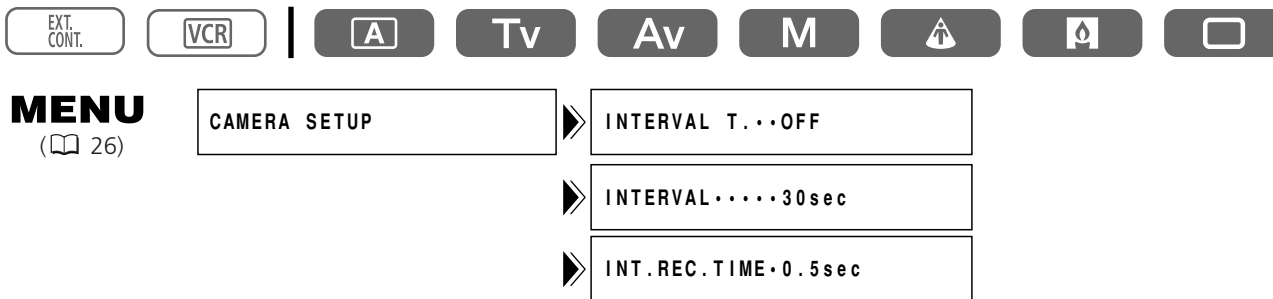

1. Open the menu and select [CAMERA SETUP].
2. Select [INTERVAL T.] and set it to [ON].
3. Select [INTERVAL] and select an interval.
4. Select [INT.REC.TIME] and select a recording time.
5. Close the menu.

"INT T." flashes.

Recording with the Interval Timer



Press the start/stop button to start recording.

- Interval recording starts and "INT T." stops flashing.
- When the interval is set to 30 seconds or 1 minute, the camcorder goes into record pause mode during the recordings. When set to 5 or 10 minutes, the camcorder goes into stop mode during the recordings.

To Pause Interval Recording

Press the start/stop button.

- The camcorder returns to record pause mode and "INT T." starts flashing.
- Press the start/stop button to restart recording.

To Finish Interval Recording

1. Press the start/stop button.

2. Open the menu and select [CAMERA SETUP]. Select [INTERVAL T.], set it to [OFF] and close the menu.



- When you record for a long time (more than 12 hours), we recommend turning off the screen display by pressing the EVF DISPLAY button.
- When the display remains shown on the screen, turn off the camcorder. They will disappear in a few hours.
- The remaining tape display may not appear.

Recording with the Self-Timer

E

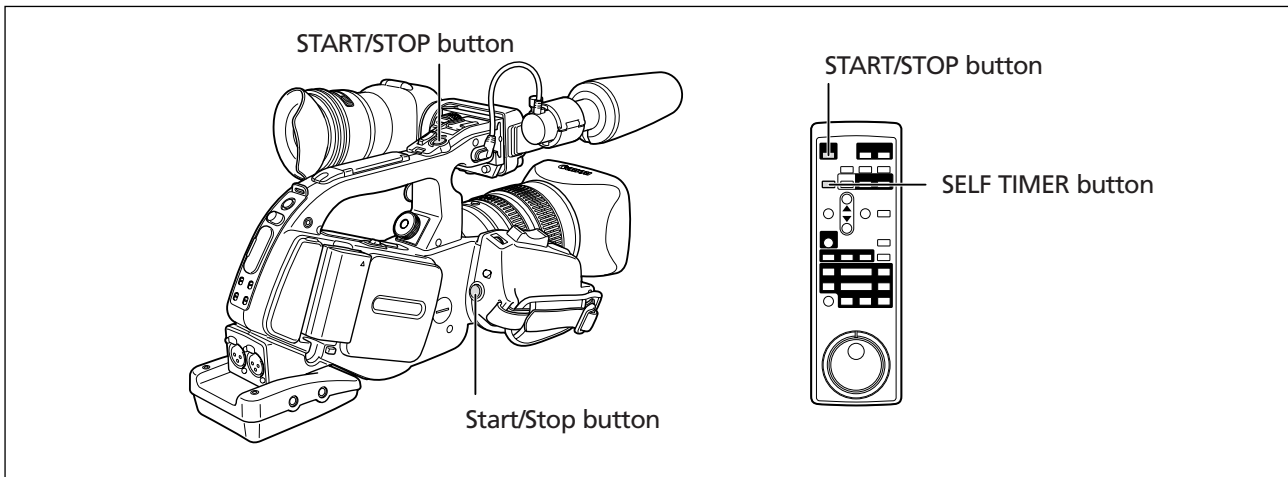

1. Press the SELF TIMER button on the wireless controller.

"⌚" appears.

2. Press the start/stop button.

The camcorder starts recording after a 10-second countdown (2 seconds when using the wireless controller). The countdown appears on the screen.



- To cancel the self-timer, press the SELF TIMER button. Once the countdown has begun, you can also press the start/stop button to cancel the self-timer.
- The self-timer will be canceled when you turn off the camcorder.
- The self-timer can also be activated through the menu: Open the menu and select [CAMERA SETUP]. Select [SELF TIMER], set it to [ON ⌚] and close the menu.

Using the DV Control

This feature enables the XL2 to control the record and stop function of a connected IEEE1394 storage/recording device. The device must comply with the IEEE1394 AV/C protocol.

Users of Windows XP can also download the DV-PC Recorder from the Canon Homepage to record video/audio to the computer's hard disk. For details, refer to the *DV-PC Recorder Software* leaflet.

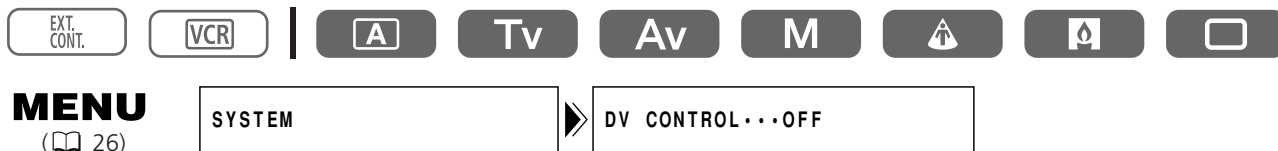

1. Open the menu and select [SYSTEM]. Select [DV CONTROL], set it to [ON] and close the menu.

2. Press the start/stop button.

When the XL2 is in record pause mode:

XL2: Recording Connected device: Recording

When the XL2 is recording:

XL2: Record pause mode Connected device: Record pause mode

When the XL2 is not ready for recording (no cassette loaded etc.)

Connected device: Recording/record pause mode

After loading a cassette while the connected device is recording:

XL2: Recording Connected device: Continues recording

Pressing the start/stop button again:

XL2: Record pause mode Connected device: Record pause mode



○ The status of the connected device is indicated as follows:

- DV** ● Connected device is recording
- DV** ■ Connected device is in record pause or stop mode
- DV** --- Connected device is in a mode other than record pause or stop
- DV** [DV CONTROL] is set to [ON], but no DV device is connected

- When the XL2 stops recording without operating the start/stop button (e.g. tape has reached the end) while both the XL2 and the connected device are recording, the connected device continues recording.
- When connecting two XL2s via a DV cable, make sure to set [DV CONTROL] of the connected device to [OFF].
- Only one device can be connected to the XL2 for DV control.
- DV control may not work properly depending on the connected non-Canon device.
- The DV control setting is retained by the camcorder even if you turn the power off. Make sure to check the setting after use of the DV control function, as the tape in the connected device may be overwritten.
- Do not use a DV cable longer than 14.8 ft. (4.5 m).

Other Camcorder Functions/Settings

Changing the Recording Mode (SP/LP)

You can choose between SP (standard play) and LP (long play). LP extends the tape usage by 1.5 times.

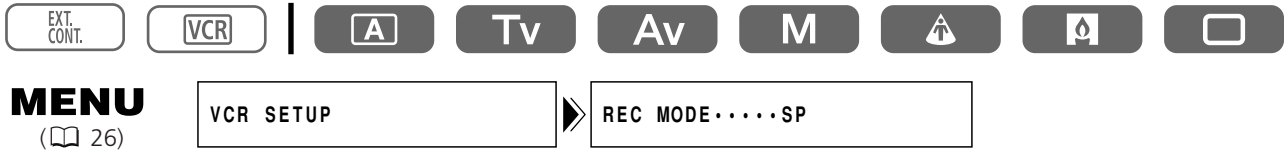

To change to LP mode, open the menu and select [VCR SETUP]. Select [REC MODE], set it to [LP] and close the menu.



Depending on the nature and usage condition of the tape, picture and sound recorded in LP mode may be distorted. We recommend using the SP mode for important recordings.



- If you record in both SP and LP modes on the same tape, the playback picture may become distorted, and the time code may not be written correctly.
- If you play back a tape that has been recorded in LP mode with another digital device on this camcorder, or vice versa, picture and sound may become distorted.

Superimposing the Screen Displays

Character record is a feature that allows for the superimposition of meta data - month, day, hour, minute and second - permanently burned on to the video. This is ideal for surveillance and law enforcement use.

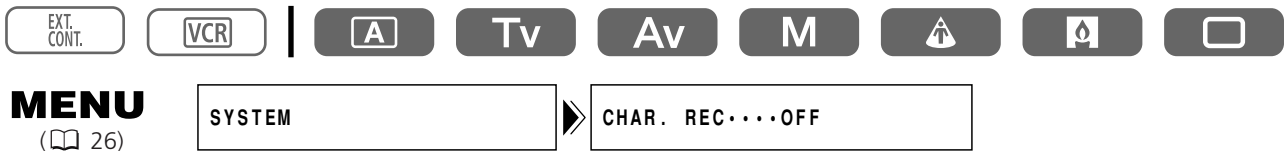

Open the menu and select [SYSTEM]. Select [CHAR. REC], set it to [ON] and close the menu.



- Make sure to set [CHAR. REC] to [OFF] when you do not wish to superimpose the screen displays.
- Superimposed screen displays cannot be erased later.

Turning Off the Tally Lamps

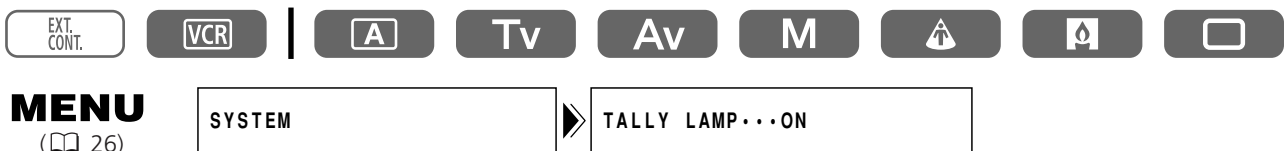

Open the menu and select [SYSTEM]. Select [TALLY LAMP], set it to [OFF] and close the menu.

The tally lamps still light up when the camcorder receives a signal from the wireless controller, or during self-timer countdown.

Changing the Display Language

The language used in the camcorder displays and menu items can be changed to Simplified Chinese or Japanese.

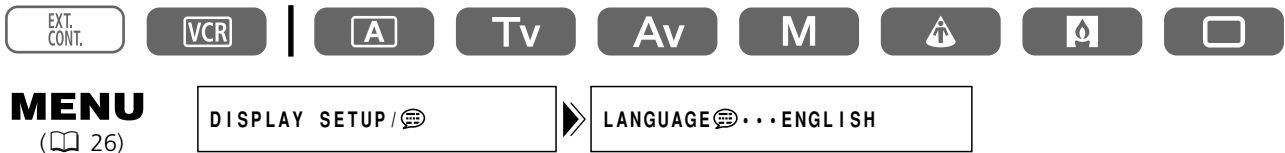

To change the display language, open the menu and select [DISPLAY SETUP/ [language icon]]. Select [LANGUAGE [language icon]], select a language and close the menu.



- If you have mistakenly changed the language, follow the [language icon] mark next to the menu item to change the setting.
- The displays "MENU" and "SET" at the bottom of the screen refer to the button names on the camcorder and will not change when you change the language.

Changing the Date Format

You can select between three date formats. For example, [JAN. 1, 2004], [1. JAN. 2004] and [2004. 1. 1].

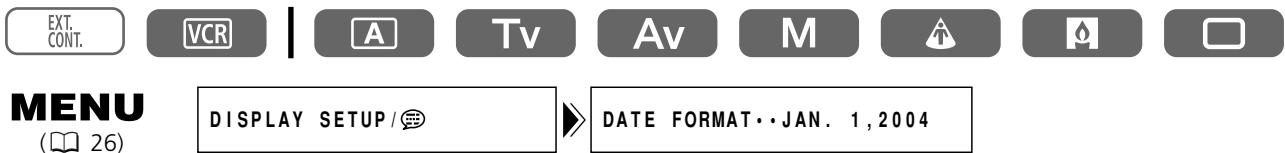

Open the menu and select [DISPLAY SETUP/ [language icon]]. Select [DATE FORMAT], select a format and close the menu.

Playing Back a Tape

If the playback picture is distorted, clean the video heads using a Canon Head Cleaning Cassette or a commercially available digital video head-cleaning cassette (📖 110).

E

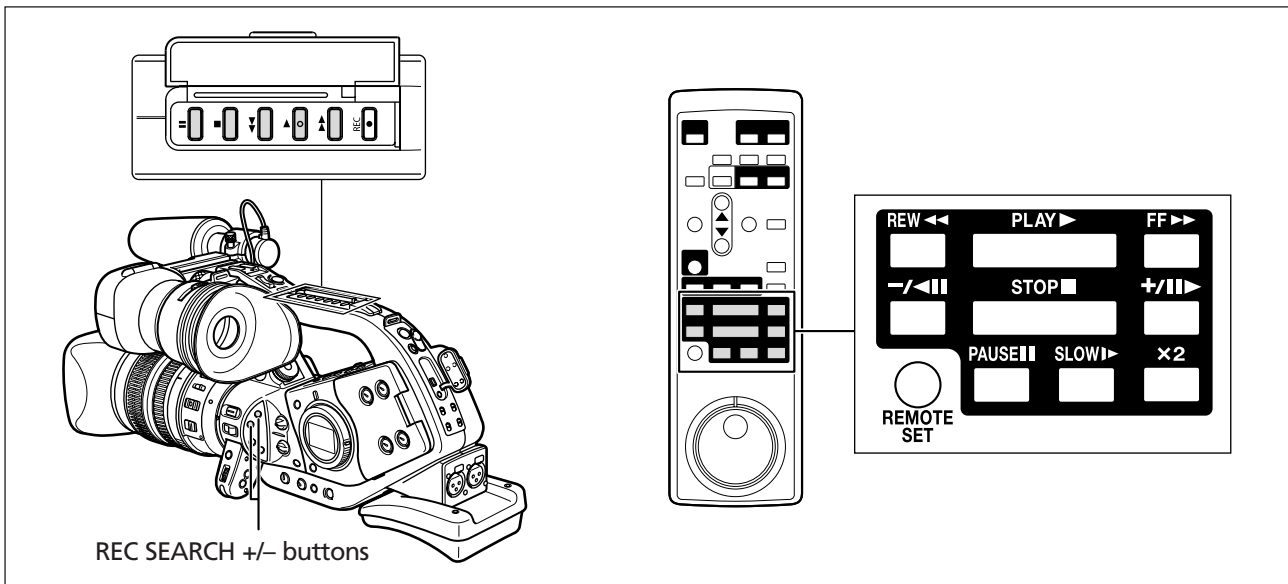

1. Set the POWER dial to VCR.
2. Press the ◀◀ button to rewind the tape.
3. Press the ▶ button to begin playback.
4. Press the ■ button to stop playback.

Special Playback Modes

■ (Playback Pause)

To pause playback, press the ■ button during normal playback.

▶▶ (Fast Forward Playback) / ◀◀ (Rewind Playback)

Plays back the tape at 9.5 times normal speed (forward or reverse). Press and hold the button during normal playback or fast forward.

-/◀◀ (Reverse Playback)

Press the button on the wireless controller during normal playback. Press the ▶ (play) button to return to normal playback.

+/▶▶ (Frame Advance) / -/◀◀ (Frame Reverse)

Plays back frame-by-frame. Press the button on the wireless controller repeatedly during playback pause. Press and hold it to play back continuous frame advance/frame reverse.

Playback

SLOW ▶ (Slow Forward)/(Slow Reverse)

Plays back at about 1/3 normal speed. Press the button on the wireless controller during normal or reverse playback. Press the ▶ (play) button to return to normal playback.

× 2 (Forward ×2 Playback)/(Reverse ×2 Playback)

Plays back at 2 times normal speed. Press the button on the wireless controller during normal or reverse playback. Press the ▶ (play) button to return to normal playback.

Edit search

Press and hold the REC SEARCH +/- button in playback pause mode. When you release the button, the camcorder returns to playback pause mode.



- There is no sound during special playback.
- The picture may become distorted during some special playback modes.
- The camcorder stops the tape automatically after 5 minutes in playback pause mode to protect tape and video heads.

Shuttle Dial

Use the shuttle dial in play or playback pause mode to control the playback speed and direction. Turn the shuttle dial to select slow, ×1 and ×2 playback modes (both forward and reverse), as well as fast forward and rewind playback. Turn it fully to the left/right to rewind/fast forward while the tape is stopped.

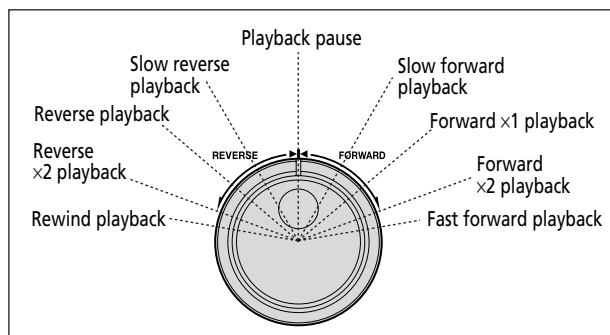

Jog Dial

Turn the Jog dial during playback or playback pause for frame advance/reverse or slow forward/slow reverse playback (depending on how far you turn the dial).

When you stop turning the dial, the camcorder goes into playback pause mode.

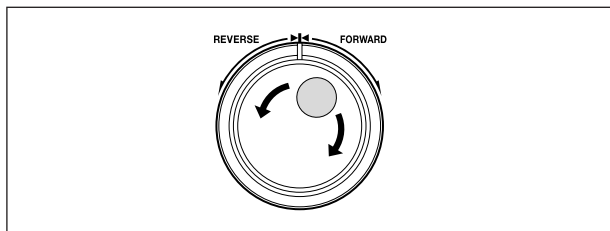

Playing Back on a TV Screen

TVs with S (S1)-Video Input Terminal

Refer also to the TV or VCR instruction manual.

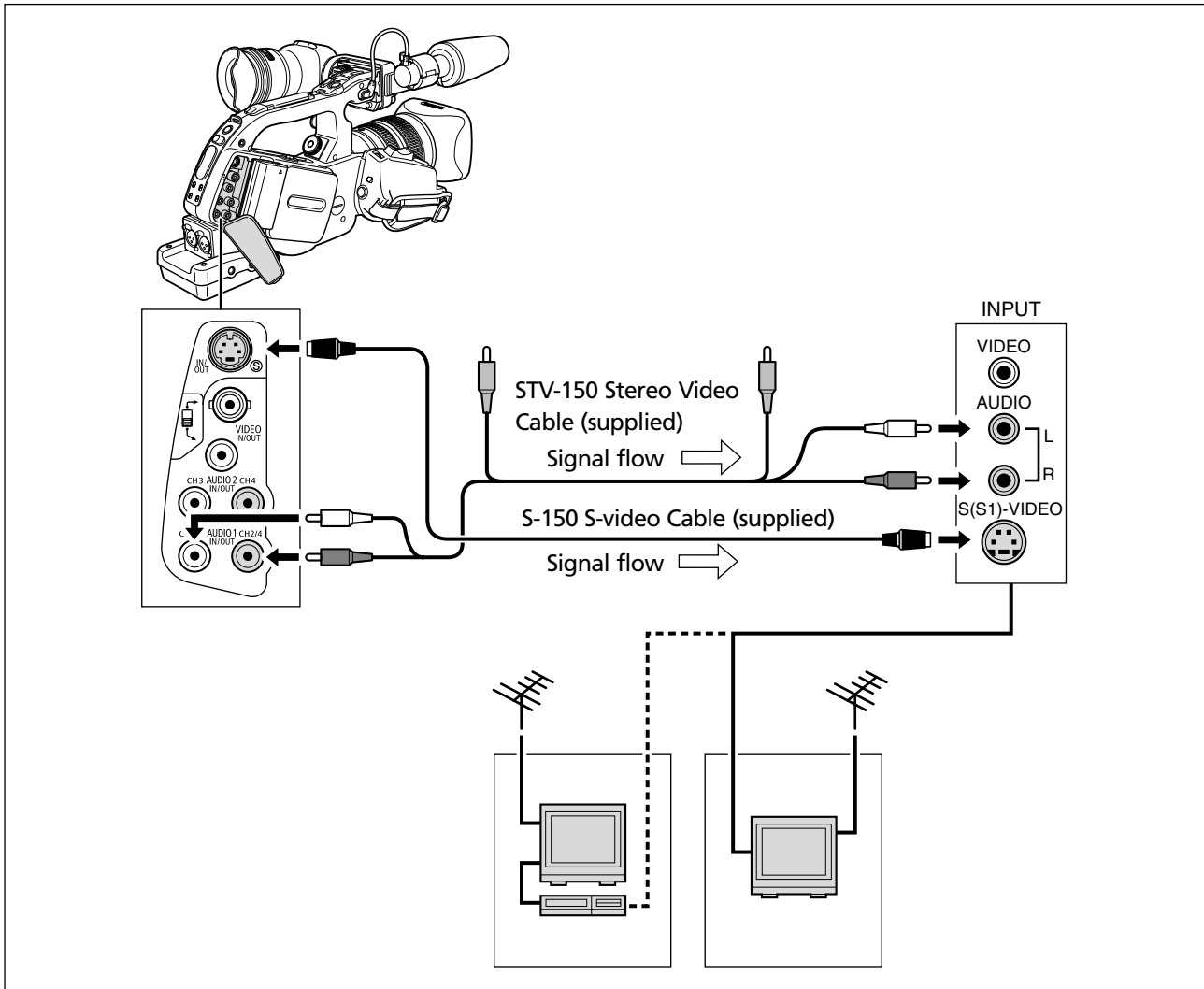

1. Turn off all devices before starting the connections.
2. Connect the S-150 S-video Cable to the S-video terminals.
3. Connect the STV-150 Stereo Video Cable to the camcorder's AUDIO1 terminals and the audio terminals of the TV/VCR.
4. If connecting to a TV, set the input selector to VIDEO. If connecting to a VCR, set the input selector to LINE.



- We recommend powering the camcorder from a household power source.
- The picture quality is higher when connecting to a TV with an S (S1) terminal.
- TVs with S (S1)-terminal or Video ID-1 system: Recordings made in the 16:9 mode will be automatically played back in widescreen mode.

E

Playback

TVs with Audio/Video Terminals

Refer also to the TV or VCR instruction manual.

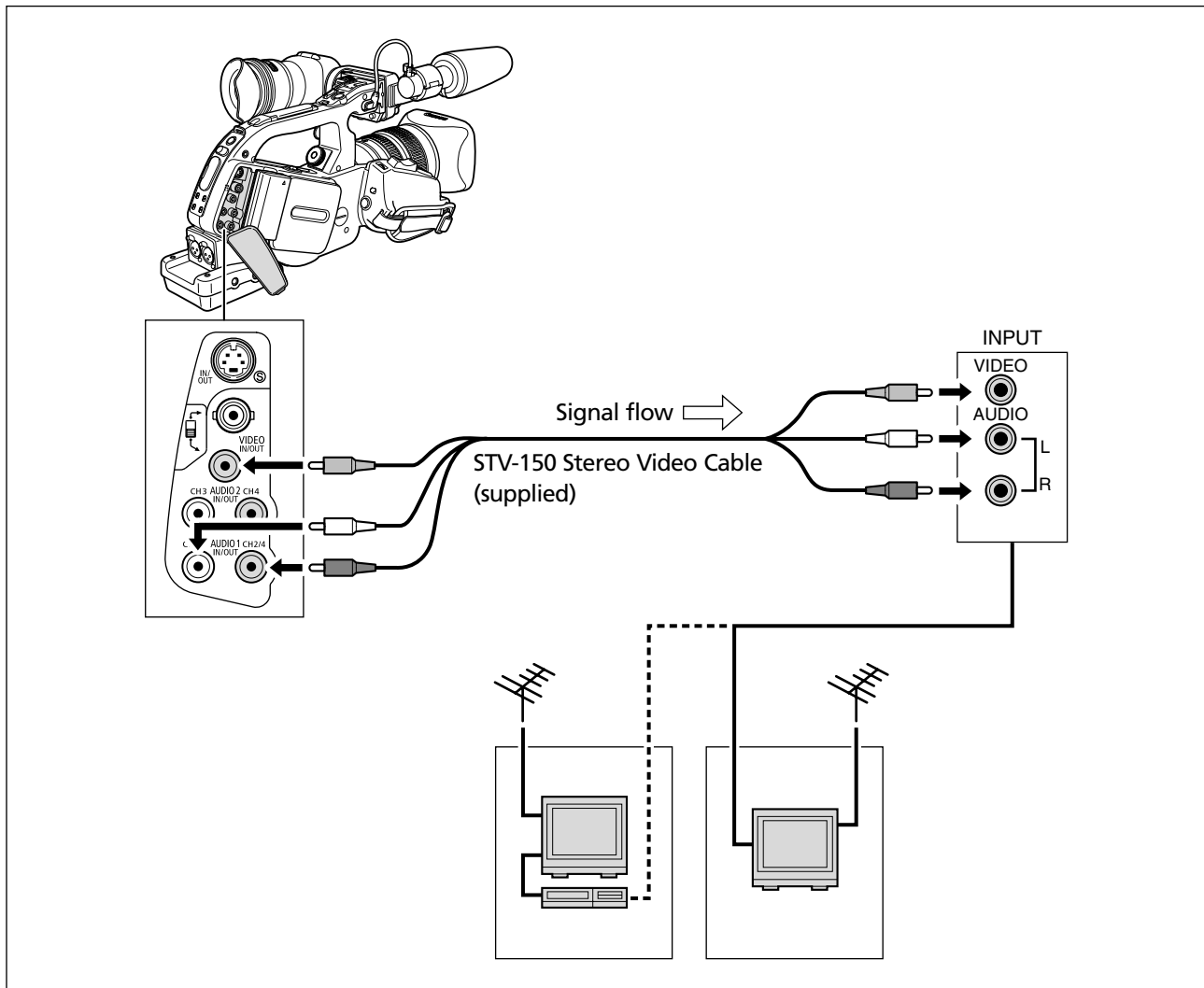

1. Turn off all devices before starting the connections.
2. Connect the STV-150 Stereo Video Cable to the camcorder's VIDEO and AUDIO1 terminals and the audio/video terminals on the TV/VCR.
3. If connecting to a TV, set the input selector to VIDEO. If connecting to a VCR, set the input selector to LINE.



When connecting to the RCA terminal, set the RCA/BNC selector to RCA. When connecting to the BNC terminal, set the RCA/BNC selector to BNC.

Audio Output

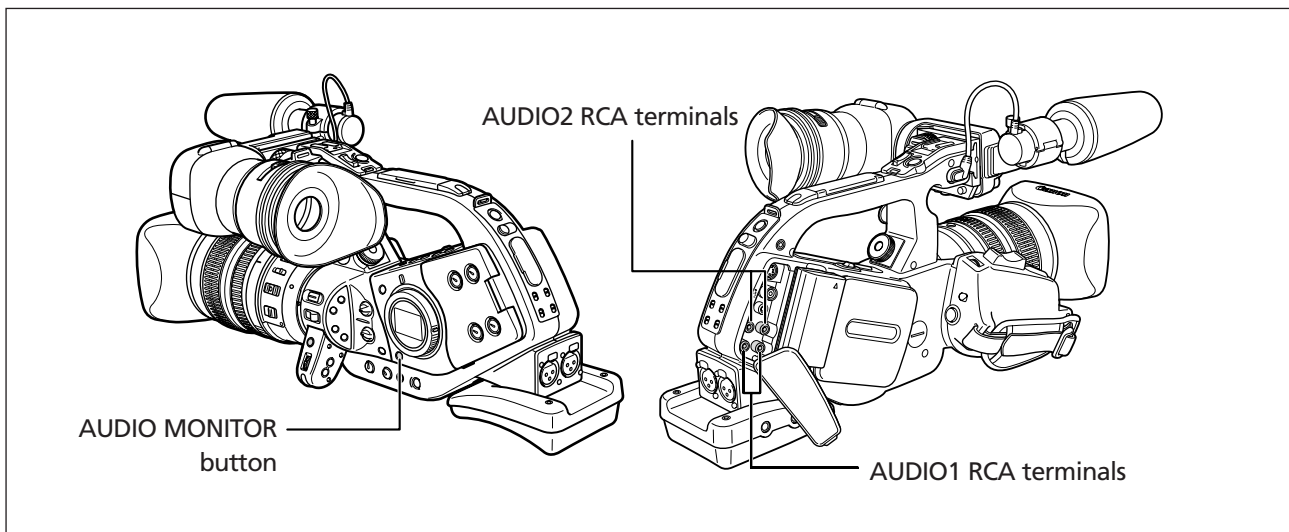

Selecting the Audio Output of the RCA Terminals



Press the **AUDIO MONITOR** button.

The setting changes with each press of the button in the order of CH $\frac{1}{2}$, CH $\frac{3}{4}$ and CH $\frac{1}{2}$ +CH $\frac{3}{4}$.

Selecting the Audio Channels



MENU
(26)

AUDIO SETUP

SEL AUDIO CH·CH1/CH2

Open the menu and select [AUDIO SETUP]. Select [SEL AUDIO CH], select a setting option and close the menu.

Selecting the Audio Mix



MENU
(26)

AUDIO SETUP

MIX SELECT...VARIABLE

1. Open the menu and select [AUDIO SETUP]. Select [MIX SELECT], set it to [VARIABLE] or [FIXED] and close the menu.
2. When you have selected [VARIABLE], adjust the mix balance with the MIX BALANCE CH1/2 and CH3/4 buttons on the wireless controller.

Returning to a Pre-marked Position

If you wish to return to a particular scene later, mark the point with the zero set memory, and the tape will stop at that point when you rewind/fast forward the tape. This function is operated with the wireless controller.

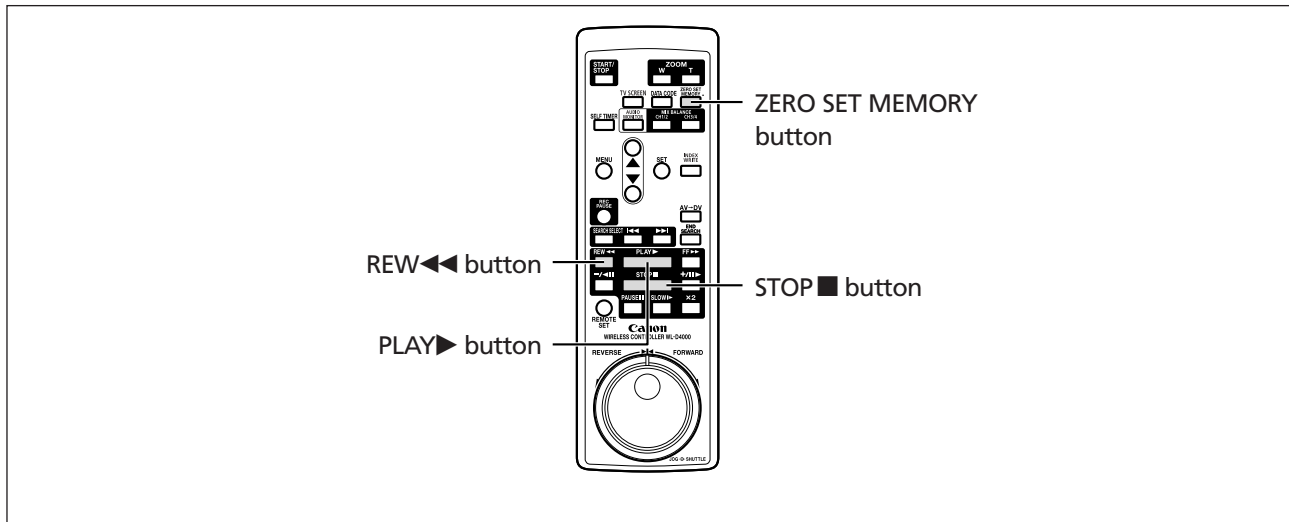

- 1. Press the ZERO SET MEMORY button at the point you wish to return to later.**
 - "0:00:00 M" appears.
 - To cancel, press the ZERO SET MEMORY button again.
- 2. When you have finished playback, rewind the tape.**
 - "◀◀ RTN" appears.
 - The tape stops automatically at "0:00:00".
 - The tape counter changes to time code.



The zero set memory may not function correctly when the time code has not been recorded consecutively.

Index Search

You can locate the point at which you have recorded the index signal (📖 75).
This function is operated with the wireless controller.

E

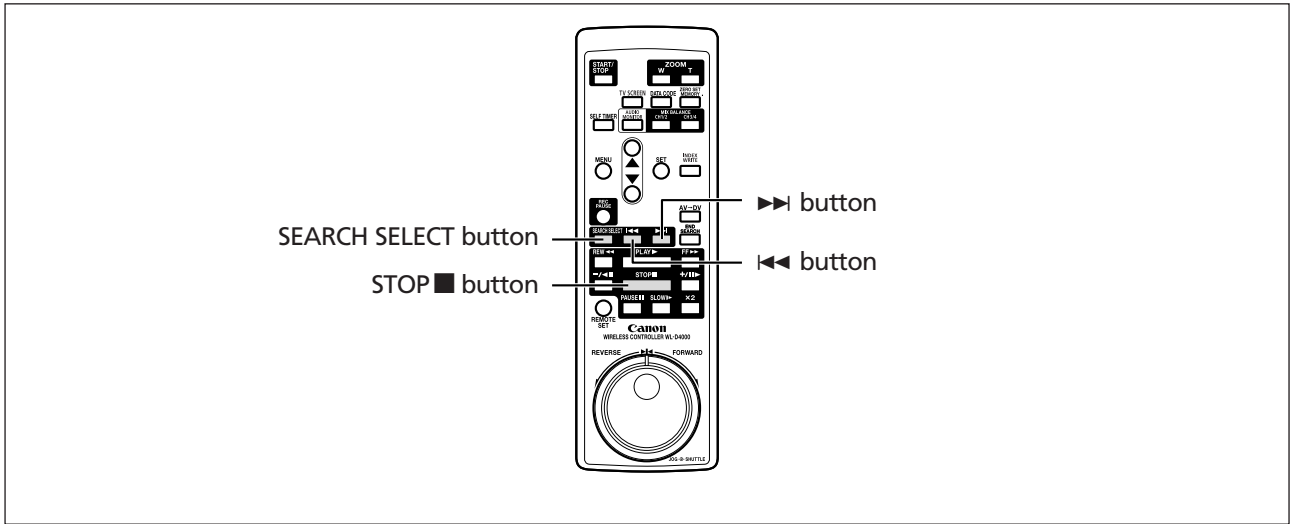

1. Press the **SEARCH SELECT** button to display “INDEX SEARCH”.
2. Press the **▶▶** or **◀◀** button to begin searching.
 - Press more than once to search for further index signals (up to 10 times).
 - Press the **STOP** button to stop searching.

 Playback may start slightly before or after the index signal.

Playback

Date Search

You can locate the change of the date/time zone with the date search function. This function is operated with the wireless controller.

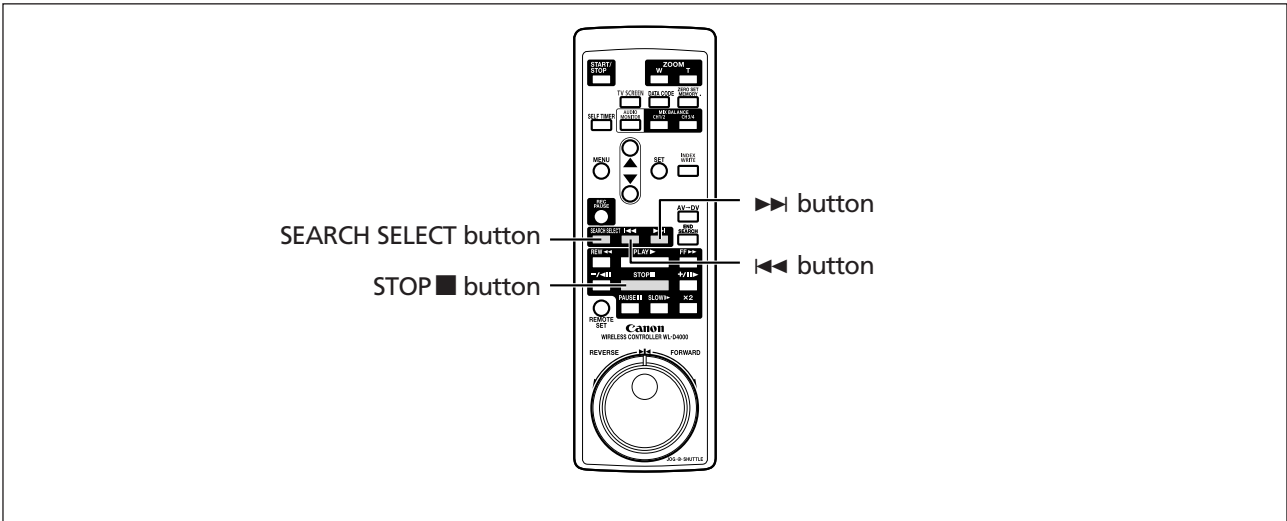

1. Press the SEARCH SELECT button to display "DATE SEARCH".

2. Press the ►► or ◀◀ button to begin searching.

- Press more than once to search for further date changes (up to 10 times).
- Press the STOP ■ button to stop searching.



- A recording of longer than a minute per date/area is required.
- Date search may not function if the data code is not correctly displayed

Displaying the Data Code

The camcorder maintains a data code containing recording date and time and other camera data such as shutter speed, gain and exposure (f-stop). When you play back a tape, you can display the data code and select the data code combination you wish to display.

E

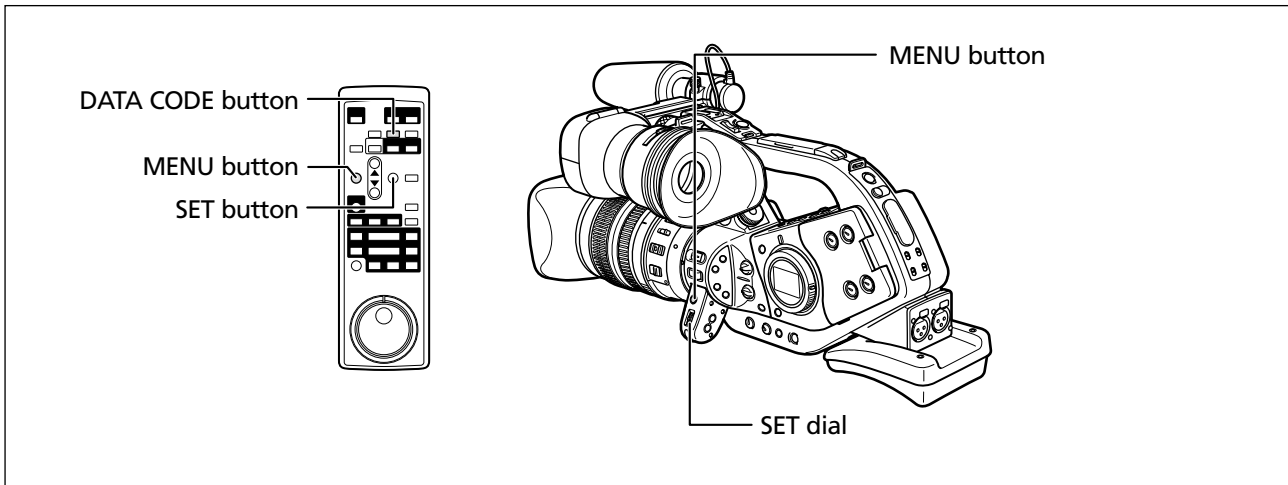

Selecting the Date/Time Display Combination



Open the menu and select [DISPLAY SETUP/ []]. Select [D/TIME SEL.], set it to [DATE] or [TIME] and close the menu.

Selecting the Data Code Display Combination

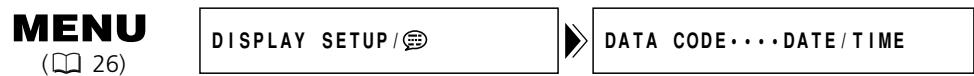

Open the menu and select [DISPLAY SETUP/ []]. Select [DATA CODE], set it to [CAMERA DATA] or [CAM.& D/T] and close the menu.

Playback

Displaying the Data Code



Press the **DATA CODE** button on the wireless controller.



The data code will not display the next time you turn on the camcorder.

Six-Second Auto Date

Date and time appear for 6 seconds when you begin playback, or to indicate that date or time zone has changed.



MENU

(26)

DISPLAY SETUP/



6SEC.DATE...OFF

Open the menu and select [**DISPLAY SETUP/**]. Select [**6SEC.DATE**], set it to [**ON**] and close the menu.

Changing the Remote Sensor Mode

Two remote sensor modes and an off setting are available to prevent interference from other Canon wireless controllers being used nearby.

E

Turning the Remote Sensor Off



MENU

(26)

SYSTEM

WL . REMOTE 1

Open the menu and select [SYSTEM]. Select [WL.REMOTE], set it to [OFF (OFF)] and close the menu.

"(OFF)" appears.

Changing the Remote Sensor Mode



MENU

(26)

SYSTEM

WL . REMOTE 1

1. On the camcorder, open the menu and select [SYSTEM]. Select [WL.REMOTE], set it to [(2)] and close the menu.

The selected mode appears for a few seconds.

2. On the wireless controller, press and hold the REMOTE SET button. Press the ZOOM T button for mode 2. Keep the button pressed for over 2 seconds.

If you have set the camcorder to mode 1, press the ZOOM W button for mode 1.



- The wireless controller returns to mode 1 when you replace the batteries. Change the mode if necessary.
- Make sure that camcorder and wireless controller are set to the same mode. Display the camcorder's mode by pressing any button on the wireless controller (except of the REMOTE SET button) and set the wireless controller's mode to the same mode. Change the batteries if the wireless controller still does not work.

Playback

Recording to a VCR or Digital Video Device

You can copy your recordings by connecting the camcorder to a VCR or a digital video device. If you connect a digital video device, you can copy recordings with virtually no generation loss in image and sound quality.

Connecting the Devices

① Connecting a VCR

See *Playing Back on a TV Screen* (□ 87).

② Connecting a Digital Video Device

Refer also to the instruction manual of the digital video device.

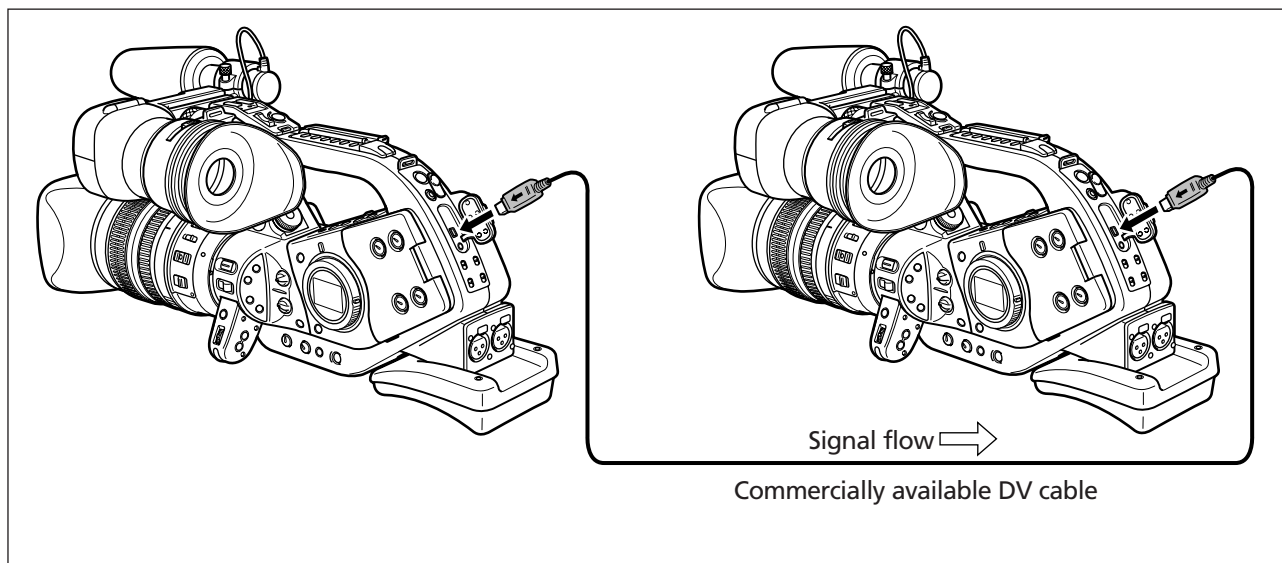

Recording



1. Set the **POWER** dial to **VCR** and load a recorded cassette.
2. **Connected device:** Load a blank cassette and set the device to record pause mode.
3. Locate the scene you wish to copy and pause playback shortly before the scene.
4. **Play back the tape.**
5. **Connected device:** Begin recording when the scene you wish to copy appears. Stop recording when copying is complete.
6. **Stop playback.**



- When connecting a VCR, the quality of the edited tape will be slightly lower than that of the original.
- When connecting a digital video device:
 - If the picture does not appear, reconnect the DV cable or turn the camcorder off and back on again.
 - Proper operation cannot be guaranteed for all digital video devices equipped with a DV terminal. If operation does not work, use the S-video or the audio and video terminals.

Recording from Analog Video Devices (VCR, TV or Camcorder)

You can record videos or TV programs from a VCR or analog camcorder on the tape in the camcorder.



1. Connect the camcorder to the analog video device.

See *Playing Back on a TV Screen* (□ 87).

2. Set the POWER dial to VCR and load a blank cassette.

3. Open the menu and select [AUDIO SETUP]. Select [AUDIO MODE], select a setting option and close the menu.

4. Select the audio input.

2-channel recording: Select the input with the INPUT SELECT switch of AUDIO1 (for analog line-in, set it to AUDIO1).

4-channel recording: Select the input with the INPUT SELECT switch of AUDIO1 and AUDIO2 (for analog line-in, set it to AUDIO1 and AUDIO2).

5. Connected device: Load the recorded cassette.

6. Press the ● and ■ button (or the REC PAUSE button on the wireless controller).

In record pause mode and during recording, you can check the picture on the screen.

7. Connected device: Play back the tape.

8. Press the ■ button (or the PAUSE ■ button on the wireless controller) when the scene you wish to record appears.

Recording starts.

9. Press the ■ button to stop recording.

- Press the ■ button to pause recording.
- Press the ■ button again to restart recording.

10. Connected device: Stop playback.



When you press only the ● button in step 6, recording starts immediately.

Recording from Digital Video Devices (DV Dubbing)

You can record from other digital video devices equipped with a DV terminal with virtually no loss in picture and sound quality.



1. Connect the camcorder to the digital video device.

See *Connecting a Digital Video Device* (□ 96).

2. Set the POWER dial to VCR and load a blank cassette.

Make sure that [AV→DV] is set to [OFF] (□ 100).

3. Connected device: Load the recorded cassette.

4. Press the ● and || button (or the REC PAUSE button on the wireless controller).

In record pause mode and during recording, you can check the picture on the screen.

5. Connected Device: Play back the tape.

6. Press the || button (or the PAUSE || button on the wireless controller) when the scene you wish to record appears.

Recording starts.

7. Press the ■ button to stop recording.

- Press the || button to pause recording.
- Press the || button again to restart recording.

8. Connected Device: Stop playback.



- Blank sections may be recorded as anomalous picture.
- If the picture does not appear, reconnect the DV cable or turn the camcorder off and back on again.
- You can only record signals from devices with the **DV** logo recording in SD system in SP or LP format.
- When you press only the ● button in step 4, recording starts immediately.

Copyright Signal

Certain software tapes are copyright protected. If you attempt to play back such tape, "COPYRIGHT PROTECTED PLAYBACK IS RESTRICTED" appears and you will not be able to view the contents of the tape. If you attempt to record from such tape via the DV terminal, "COPYRIGHT PROTECTED DUBBING RESTRICTED" appears and you will not be able to record the contents of the tape.

Converting Analog Signals into Digital Signals (Analog-Digital Converter)

By connecting the camcorder to a VCR or 8mm video camcorder, you can convert analog video/audio signals to digital signals and output the digital signals via the DV terminal. The DV terminal serves as output terminal only.

Connecting the Devices

Turn off all devices before starting the connections. Unload the tape from the camcorder. Refer also to the instruction manual of the connected device.

You can also connect to the VIDEO terminal (📖 88).

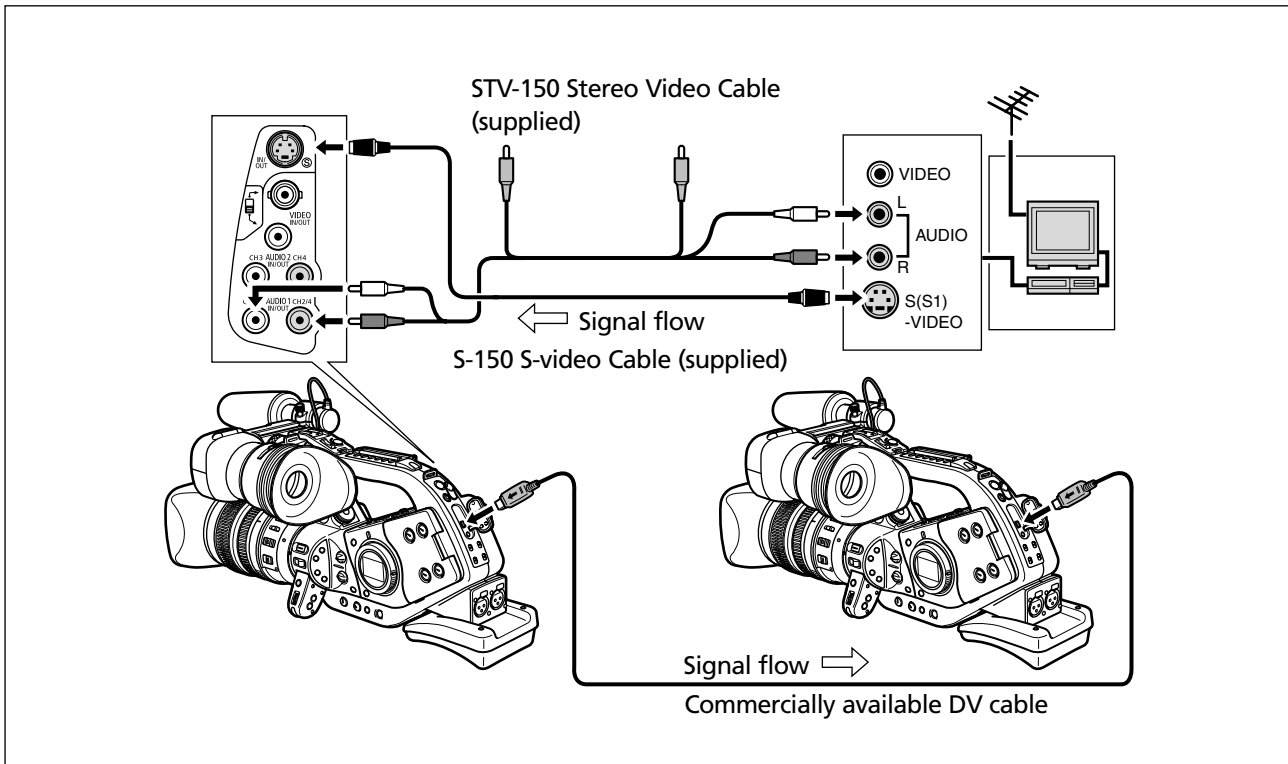

Turning On the Analog-Digital Converter



MENU

(26)

VCR SETUP

▶▶ AV→DV.....OFF

Open the menu and select [VCR SETUP]. Select [AV→DV], set it to [ON] and close the menu.



- Depending on the signal sent from the connected device, the conversion from analog to digital signals might not work properly (e.g., signals that include copyright protective signals or anomalous signals such as ghost signals).
- For normal use, set [AV→DV] to [OFF]. If it is set to [ON], digital signals cannot be input via the camcorder's DV terminal.
- Depending on the software and the specifications of your computer, you may not be able to transfer converted signals via the DV terminal.



- We recommend powering the camcorder from a household power source.
- You can also press the AV→DV button on the wireless controller. The setting changes with each press of the button.

Connecting to a Computer Using a DV (IEEE1394) Cable

You can transfer recordings to a computer equipped with a IEEE1394 (DV) terminal or IEEE1394 capture board. Use the editing software supplied with your computer/capture board to transfer video recording from tape to computer. Refer to the instruction manual of the software.

A driver is preinstalled on Windows operating systems later than Windows 98 Second Edition and on Mac operating systems later than Mac OS 9, and will be installed automatically.

Users of Windows XP can also download the DV-PC Recorder from the Canon Homepage to record video/audio to the computer's hard disk. For details, refer to the *DV-PC Recorder Software* leaflet.

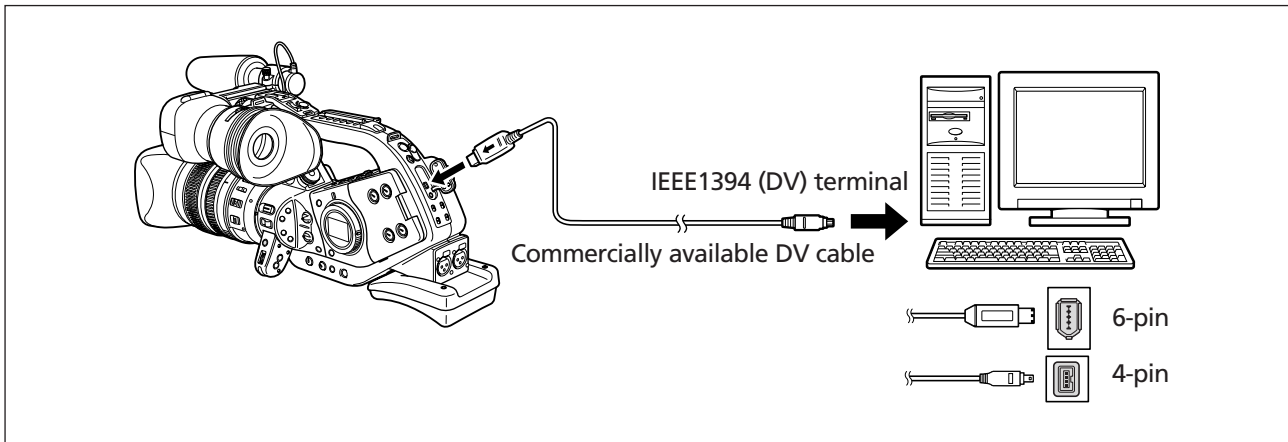

- Operation may not work correctly depending on the software and the specifications/settings of your computer.
- If the computer freezes while you have connected the camcorder, disconnect and reconnect the DV cable. If the problem persists, disconnect the interface cable, turn off camcorder and computer, turn camcorder and computer back on and reconnect them.
- The XL2 cannot be used with DV Messenger.



Refer also to the instruction manual of the computer.

Settings Retained at Power Off or STANDBY Mode

The following list shows the settings that are retained when you turn the power off or press the STANDBY button when the backup battery is installed.

Recording Mode

	Power Off	STANDBY Mode
Aperture setting in Av mode		○
Shutter speed setting in Tv mode		○
Aperture, shutter speed setting in Manual mode		○
Custom white balance		○
Exposure lock on/off	Returns to off	○
Aperture, shutter speed setting during exposure lock	Reset	○
Color bars setting	Reset	○
Color bars on/off	Reset	○
CAMERA MENU settings*		○
Self-timer on/off	Returns to off	
Interval timer on/off	Returns to off	
TV SCREEN on/off		○
EVF display	Returns to normal display	
Side panel light	Returns to off	
Zero set memory		○

* Except for self-timer and interval timer on/off.

The following list shows the settings that are retained when you change the programmed AE mode or frame rate.

Recording Mode

	When you change to another programmed AE mode other than Easy Recording	When you change to Easy Recording mode	When you change the frame rate
Aperture setting in Av mode	<input type="radio"/>		Reset
Shutter speed setting in Tv mode	<input type="radio"/>		Reset
Aperture, shutter speed setting in Manual mode	<input type="radio"/>		Reset
Custom white balance	<input type="radio"/>		<input type="radio"/>
Exposure lock on/off	Returns to off		
Aperture, shutter speed setting during exposure lock	Reset		
Color bars setting	<input type="radio"/>		Reset
Color bars on/off	<input type="radio"/>		Reset
CAMERA MENU setting		<input type="radio"/>	
Self-timer on/off		<input type="radio"/>	
Interval timer on/off		<input type="radio"/>	
TV SCREEN on/off		<input type="radio"/>	
EVF display		<input type="radio"/>	
Side panel light		<input type="radio"/>	
Zero set memory		<input type="radio"/>	

Screen Displays

Hiding the Displays on the Camcorder Screen

You can hide the displays on the screen to have a clear screen for playback.



MENU
( 26)



Open the menu and select **[DISPLAY SETUP/ ]**. Select **[DISPLAYS]**, set it to **[OFF <PLAYBK>]** and close the menu.

- Warning messages still appear, and the data code appears if turned on.
- Tape operation displays appear for 2 seconds.

Hiding/Showing the Displays on the TV Screen

When you connect a TV for recording, you can select to hide the camcorder displays on the TV screen. For playback, you can show the camcorder displays on the TV screen.



MENU
( 26)



Open the menu and select **[DISPLAY SETUP/ ]**. Select **[TV SCREEN]**, set it to **[OFF]** and close the menu.

The displays disappear from the TV screen.



MENU
( 26)



Open the menu and select **[DISPLAY SETUP/ ]**. Select **[TV SCREEN]**, set it to **[ON]** and close the menu.

The displays appear on the TV screen.

Screen Displays during Recording

See also [34](#).

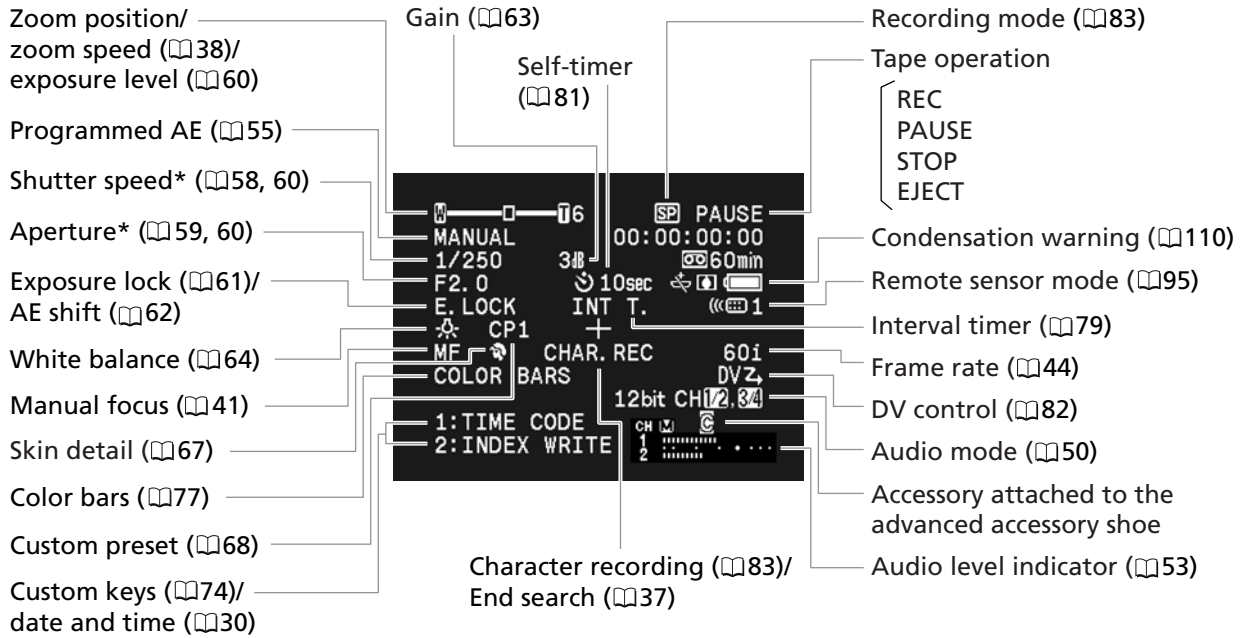

* In Manual mode.

Screen Displays during Playback

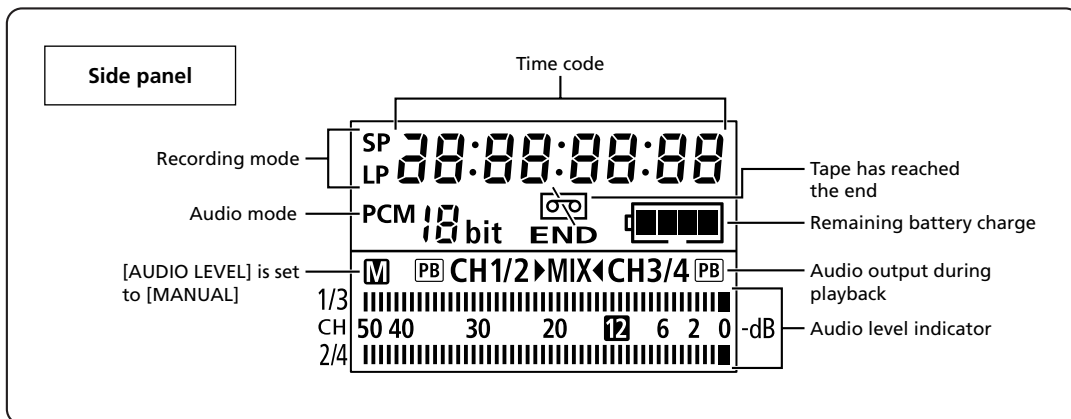
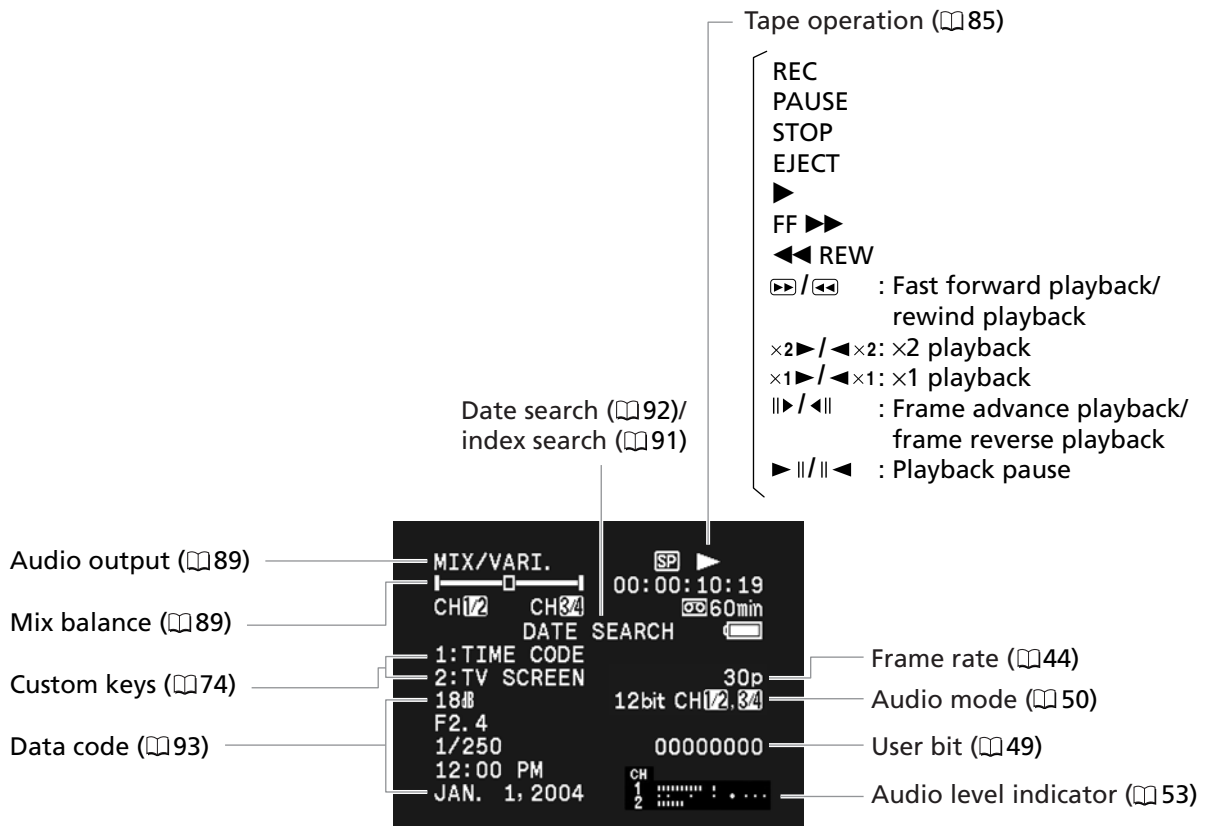

List of Messages

Message	Explanation	 Page
SET THE TIME ZONE, DATE AND TIME	You have not set the time zone, date and time. This message appears each time you turn the power on until you set the time zone, date and time.	30
CHANGE THE BATTERY PACK	Battery pack is exhausted. Replace or charge the battery pack.	13
THE TAPE IS SET FOR ERASURE PREVENTION	Cassette is protected. Replace the cassette or change the position of the protect switch.	112
REMOVE THE CASSETTE	Camcorder stopped operating to protect the tape. Unload and reload the cassette.	25
CHECK THE INPUT	DV cable is not connected, or the connected digital device is turned off.	98
CONDENSATION HAS BEEN DETECTED	Condensation has been detected in the camcorder.	110
TAPE END	Tape reached the end. Rewind the tape or replace the cassette.	–
HEADS DIRTY, USE CLEANING CASSETTE	Video heads are dirty. Clean the video heads.	110
ENTERING "POWER STANDBY"	Appears for 1 second when you press the STANDBY button.	33
CHECK THE LENS	Lens is not correctly mounted. Turn the lens until it clicks. If the message does not disappear, unmount and remount the lens.	22
COPYRIGHT PROTECTED PLAYBACK IS RESTRICTED	You attempted to play back a copyright protected tape.	98
COPYRIGHT PROTECTED DUBBING RESTRICTED	You attempted to dub a copyright protected tape. May also appear when an anomalous signal is received during analog line-in recording, or during analog-digital conversion of a copyright protected tape.	98

Maintenance/Others

Camcorder Handling Precautions

- Do not carry the camcorder by the viewfinder or the microphone.
- Do not leave the camcorder in places subject to high temperatures, such as a sun-heated car, and high humidity.
- Do not use the camcorder in places subject to magnetic or electric fields such as near the TV transmitters or portable communication devices.
- Do not point the lens or viewfinder at strong light sources. Do not leave the camcorder pointed at a bright subject.
- Do not use the camcorder in dusty or sandy places. Dust or sand getting inside the cassette or camcorder may cause damage. Dust and sand can also damage the lens. Attach the lens cap after use.
- The camcorder is not waterproof. Water, mud or salt getting inside the cassette or camcorder may cause damage.
- Be careful of heat generated by lighting equipment.
- Do not disassemble the camcorder. If the camcorder does not function properly, consult qualified service personnel.
- Handle the camcorder with care. Do not subject the camcorder to shocks or vibration as this may cause damage.
- Avoid sudden changes in temperature. Moving the camcorder rapidly between hot and cold temperatures may cause condensation to form on its internal surfaces (☞ 110).

Storage

- If you do not intend to use the camcorder for a long time, store it in a place free of dust, in low humidity, and at temperatures not higher than 86 °F (30 °C).
- After storage, check the functions of your camcorder to make sure that the camcorder is still working properly.

Cleaning

Camcorder Body and Lens

- Use a soft, dry cloth to clean the camcorder body and lens. Never use chemically treated cloth or volatile solvents such as paint thinner.

LCD Screen

- Clean the LCD screen using a commercially available cleaning cloth for glasses.
- Condensation may form on the surface of the screen when the temperature changes suddenly. Wipe it with a soft dry cloth.

Viewfinder

1. Pull up the eye cup and open the protect cover (e.g. using a flathead screwdriver).
2. Clean the glass with a cotton swab.
3. Reattach the protect cover.

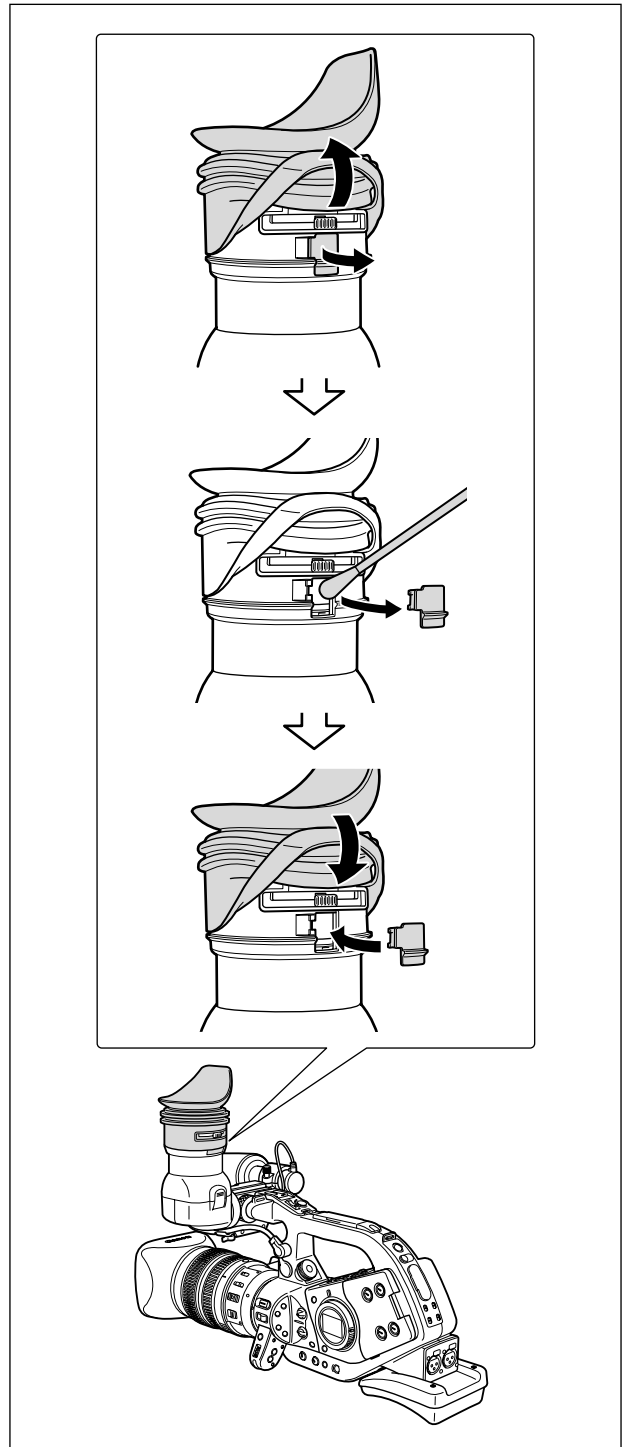

Be careful not to scratch the glass when cleaning.

Video Heads

- When the message "HEADS DIRTY, USE CLEANING CASSETTE" appears, or when the playback picture becomes distorted, the video heads need to be cleaned.
- To maintain the best picture quality, we recommend cleaning the video heads frequently with the Canon DVM-CL Digital Video Head Cleaning Cassette or a commercially available dry cleaning cassette.
- Tapes already recorded with dirty video heads may not be played back correctly even when you clean the video heads.
- Do not use wet type cleaning cassettes as this may damage the camcorder.



Condensation

Moving the camcorder rapidly between hot and cold temperature may cause condensation (water droplets) to form on its internal surfaces. Stop using the camcorder if condensation is detected. Continued use may damage the camcorder.

Condensation may form in the following cases:

When the camcorder is moved from an air-conditioned room to a warm, humid place

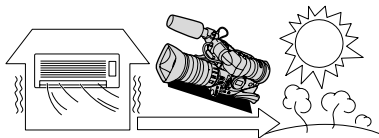

When the camcorder is moved from a cold place to a warm room

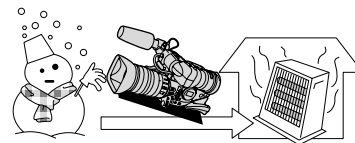

When the camcorder is left in a humid room

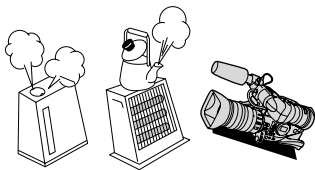

When a cold room is heated rapidly

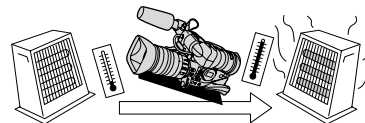

How to avoid condensation:

- Unload the cassette, place the camcorder in an airtight plastic bag and let it adjust to temperature changes slowly before removing it from the bag.

When condensation is detected:

- The camcorder stops operating, and the warning message "CONDENSATION HAS BEEN DETECTED" appears for approx. 4 seconds and "☒" starts flashing.
- If a cassette is loaded, the warning message "REMOVE THE CASSETTE" appears and "☒" starts flashing. Remove the cassette immediately and leave the cassette compartment open. Leaving the cassette in the camcorder may damage the tape.
- A cassette cannot be loaded when condensation is detected.

Resuming use:

- It takes about 1 hour until the water droplets evaporate. After the condensation warning stops flashing, wait for 1 more hour before resuming use.

Battery Pack Handling Precautions

DANGER!**Treat the battery pack with care.**

- Keep it away from fire (or it might explode).
- Do not expose the battery pack to temperature higher than 140 °F (60 °C). Do not leave it near a heater or inside a car in hot weather.
- Do not try to disassemble or modify it.
- Do not drop or knock it.
- Do not get it wet.

- Charged battery packs continue to discharge naturally. Therefore, charge them on the day of use, or the day before, to ensure a full charge.
- Attach the terminal cover whenever a battery pack is not in use. Contact to metallic objects may cause a short circuit and damage the battery pack.
- Dirty terminals may cause a poor contact between the battery pack and the camcorder. Wipe the terminals with a soft cloth.
- Since storing a charged battery pack for a long time (about 1 year) can shorten its lifecycle or affect performance, we recommend to discharge the battery pack fully and to store it in a dry place at temperatures no higher than 86 °F (30 °C). If you do not use the battery pack for long periods, charge and discharge it fully at least once a year. If you have more than 1 battery pack, perform these precautions at the same time for all battery packs.
- Although the battery pack's operating temperature range is from 32 °F to 104 °F (0 °C to 40 °C), the optimal range is from 50 °F to 86 °F (10 °C to 30 °C). At cold temperatures, performance will temporarily decline. Warm it in your pocket before use.
- Replace the battery pack if the usable time after full charge diminishes substantially at normal temperatures.

Cassette Handling Precautions

- Rewind tapes after use. If the tape becomes slack and damaged, it may cause picture and sound distortion.
- Return cassettes in the case and store them upright.
- Do not leave the cassette in the camcorder after use.
- Do not use spliced tapes or nonstandard cassettes as they may damage the camcorder.
- Do not use tapes that have been jammed as video heads may become dirty.
- Do not insert anything into the small holes of the cassette, or cover them with cellophane tape.
- Handle cassettes with care. Do not drop or subject them to severe impact as this may damage the cassettes.
- Rewind tapes from time to time if they are stored for a long time.
- With cassettes equipped with a memory function, metal plated terminals may become dirty with use. Clean the terminals with a cotton swab after about 10 times of loading/unloading. The memory function is not supported by the camcorder.

Protecting Tapes from Accidental Erasure

To protect your recordings from accidental erasure, slide the tab on the cassette to the left. (This switch position is usually labeled SAVE or ERASE OFF.)

If you load a protected cassette in recording mode, the message "THE TAPE IS SET FOR ERASURE PREVENTION" appears for approx. 4 seconds and "Ⓢ" starts flashing. If you wish to record on that cassette, slide the tab back to the right.

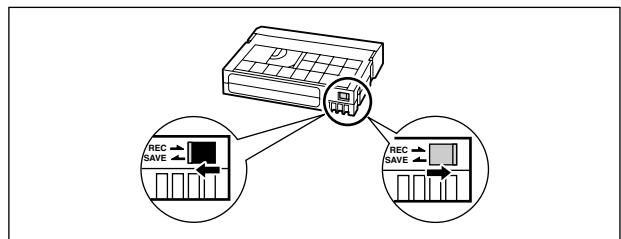

Using the Camcorder Abroad

Power Sources

You can use the compact power adapter to operate the camcorder and to charge battery packs in any country with power supply between 100 and 240 V AC, 50/60 Hz. Consult the Canon Service Center for information on plug adapters for overseas use.

Playback on a TV Screen

You can only play back your recordings on TVs with NTSC system. The NTSC system is used in the following countries/areas:

American Samoa, Antigua, Aruba, Bahamas, Barbados, Bermuda, Bolivia, Canada, Chile, Columbia, Costa Rica, Cuba, Ecuador, El Salvador, Guam, Guatemala, Greenland, Haiti, Honduras, Jamaica, Japan, Korea, Mexico, Micronesia, Myanmar, Nicaragua, Panama, Peru, Philippines, Puerto Rico, Saint Kitts and Nevis, Saint Lucia, Saint Vincent and the Grenadines, Surinam, Taiwan, Trinidad and Tobago, USA, Venezuela, Virgin Islands.

Troubleshooting

If you have a problem with your camcorder, refer to this checklist. Consult your dealer or a Canon Service Center if the problem persists.

E

Power Source

Problem	Cause	Solution	 Page
Camcorder will not turn on.	Battery pack is not correctly attached.	Attach the battery pack correctly.	13
The camcorder switches off by itself.	Power save function has been activated.	Turn on the camcorder.	32
Viewfinder switches on and off.	Battery pack is exhausted.	Replace or charge the battery pack.	13

Recording/Playback

Buttons will not work.	Cassette is not loaded.	Load a cassette.	25
"  " flashes on the screen.	Condensation is detected.	See reference page.	110
"REMOVE THE CASSETTE" appears on the screen.	Camcorder stopped operating to protect the tape.	Unload and reload the cassette.	25
The wireless controller will not work.	Camcorder and wireless controller are not set to the same remote sensor mode.	Change the remote sensor modes.	95
	Batteries of the wireless controller are exhausted.	Replace the batteries.	24

Recording

Image will not appear on the screen.	The POWER dial is not set to a recording program.	Set the POWER dial to a recording program.	32
"SET THE TIME ZONE, DATE AND TIME" appears on the screen.	Time zone, date and time are not set, or the backup battery is exhausted.	Set the time zone, date and time, or replace the backup battery and reset the date and time.	30
Pressing the start/stop button will not start recording.	Cassette is not loaded.	Load a cassette.	25
	The POWER dial is not set to a recording program.	Set the POWER dial to a recording program.	32
	The lock lever on the carrying handle is activated.	Slide the lock lever to the left and deactivate it.	33
Camcorder will not focus.	Autofocus does not work on that subject.	Focus manually.	41
	Viewfinder is not adjusted.	Adjust the viewfinder with the dioptic adjustment lever.	19
	Lens is dirty.	Clean the lens.	108
The tally lamp will not light up.	[TALLY LAMP] is set to [OFF] in the menu.	Set [TALLY LAMP] to [ON].	83

Additional Information

Recording

Problem	Cause	Solution	
A vertical light bar appears on the screen.	Bright light in a dark scene may cause a vertical light bar (smear) to appear. This is not a malfunction.	Record in the Av mode with F5.6–F8.0.	59
Viewfinder picture is blurred.	Viewfinder is not adjusted.	Adjust the viewfinder with the dioptic adjustment lever.	19
Audio is not recorded.	The INPUT SELECT switch is not set to the correct position.	Set the INPUT SELECT switch to the correct position.	51 52
	The REC LEVEL switch is set to M, and recording level is set too low.	Adjust the audio level correctly.	53
Audio is recorded in a very low level.	Microphone connected to the XLR terminal needs to be powered by the phantom power.	Set the +48V switch to ON.	51 52
	Microphone attenuator is turned on.	Set the MIC ATT. switch to OFF.	51 52

Playback

Problem	Cause	Solution	
Pressing the playback button does not start playback.	Camcorder is turned off, or is not set to VCR mode.	Set the camcorder to VCR mode.	85
	Cassette is not loaded.	Load a cassette.	25
Tape is running, but image will not appear on the TV screen.	Video heads are dirty.	Clean the video heads.	110
	You attempted to play back or dub copyright protected tape.	Stop playback/dubbing.	–

Others

Lenses with built-in image stabilizer: Detected air bubbles inside the lens.	Sometimes air bubbles may form inside the lens in airplanes or on high mountains. This is not a malfunction. The air bubbles disappear in about 1 week.	---	–
--	---	-----	---

About the CCD

Due to the construction of the CCD, in low-light recording using the slow shutter or gaining up, small specks of light may become visible on the screen. In such cases, increase the shutter speed, reduce the gain or use an additional light source such as a video light.

System Diagram (Availability differs from area to area)

E

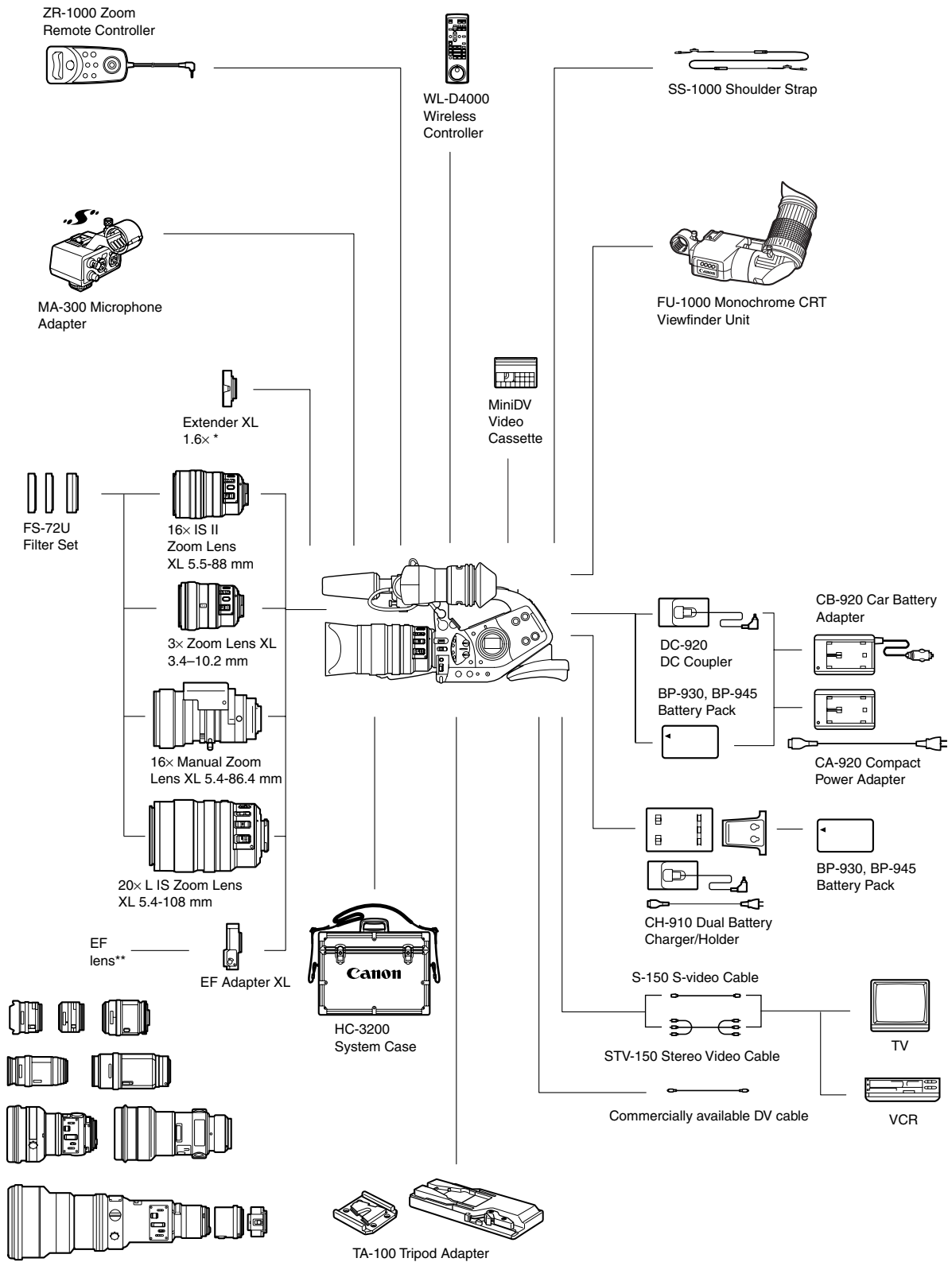

* Can be attached to the 20x L IS, 16x IS II and 16x manual zoom lenses.
 ** EF-S lenses cannot be used.

Additional Information

Optional Accessories

Call or visit your local retailer/dealer for genuine Canon video accessories. You can also obtain genuine accessories for your Canon camcorder by calling: 1-800-828-4040, Canon U.S.A. Information Center.

Use of genuine Canon accessories is recommended.

This product is designed to achieve excellent performance when used with genuine Canon accessories. Canon shall not be liable for any damage to this product and/or accidents such as fire, etc., caused by the malfunction of non-genuine Canon accessories (e.g., a leakage and/or explosion of a battery pack). Please note that this warranty does not apply to repairs arising out of the malfunction of non-genuine Canon accessories, although you may request such repairs on a chargeable basis.

Battery Packs

The BP-930 is also available as an optional accessory.

The optional BP-945 provides 50% more recording time than the BP-930.

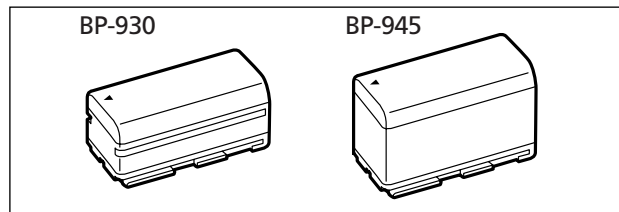

Car Battery Adapter CB-920

Use the car battery adapter to power the camcorder or charge battery packs on the move. The car battery adapter plugs into your car's cigarette lighter socket and runs off a 12-24V DC negative ground battery.

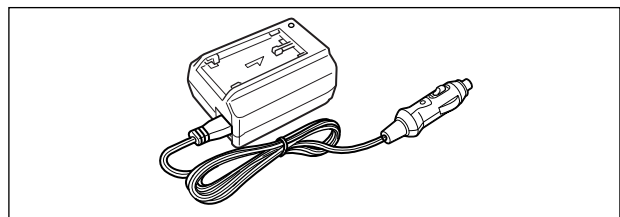

FS-72U Filter Set

Ultraviolet, neutral density and circular polarizing filters to help you take control of difficult lighting conditions.

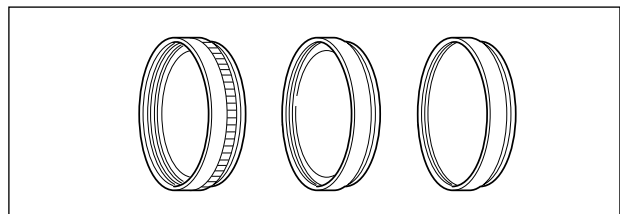

HC-3200 System Case

A solid, lockable case that provides safe and stylish protection for the camcorder during transportation and storage.

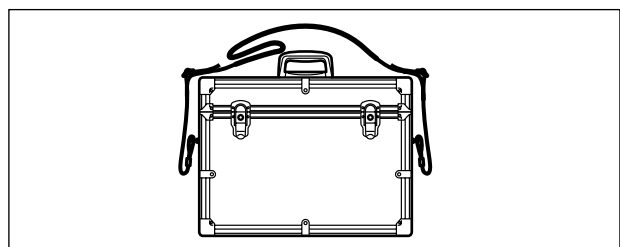

3× Zoom Lens XL 3.4–10.2 mm

A super wide-angle lens that gives a range of 32.6–97.8 mm (35 mm film equivalent).

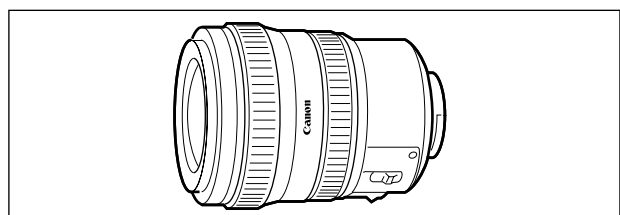

16× Manual Zoom Lens XL 5.4–86.4 mm

A high-resolution zoom lens with two zoom modes (manual and powered), built-in ND filter and AE functions.

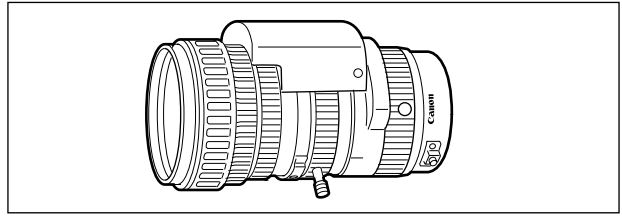
**Extender XL 1.6×**

Attach this extender between a Canon XL lens and the XL2 to boost the focal length of the lens by 1.6×.

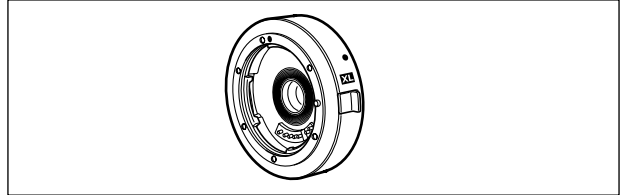
**EF Adapter XL**

This allows you to attach Canon EF lenses to the XL2. The difference in size between the XL2's 1/3-inch CCD's and 35mm film means that the effective focal length of still camera lenses is multiplied by 9.6× (4:3)/7.8× (16:9).

- Consult your local service outlet to make sure there are no compatibility problems with your chosen lens.

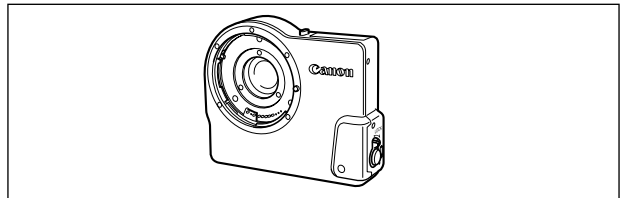
**FU-1000 Monochrome CRT Viewfinder Unit**

Professional quality B&W viewfinder with a 1.5-inch CRT.

- When you use the FU-1000 with the XL2, you can supply power from the CA-920 or optional CB-920. The battery adapter supplied with the FU-1000 is not required. Attach the DC Coupler directly to the XL2, and connect it with the CA920/CB-920.

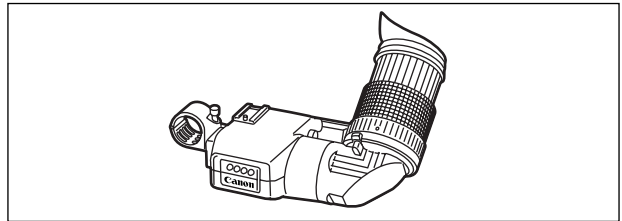
**TA-100 Tripod Adapter**

The TA-100 allows you to quickly mount/unmount the XL2 on/from a tripod.

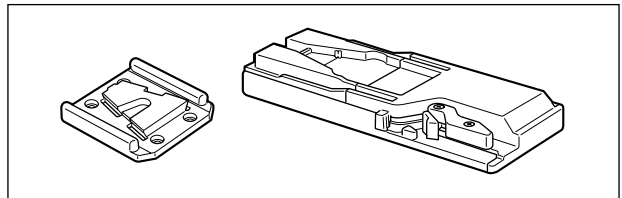
**MA-300 Microphone Adapter**

With the MA-300, you can use balanced microphones on all 4 channels.

- Phantom power cannot be used with the MA-300.

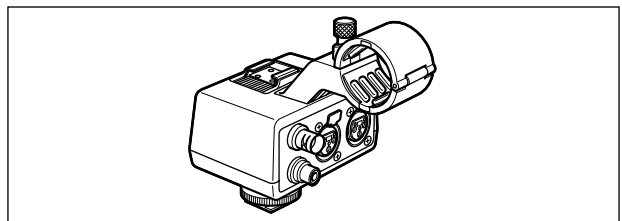

CH-910 Dual Battery Charger/Holder

The CH-910 can charge two battery packs consecutively. You can also power the camcorder by connecting the CH-910 with charged battery packs to the camcorder. When you attach two battery packs, a battery pack can be exchanged without interrupting the power supply.

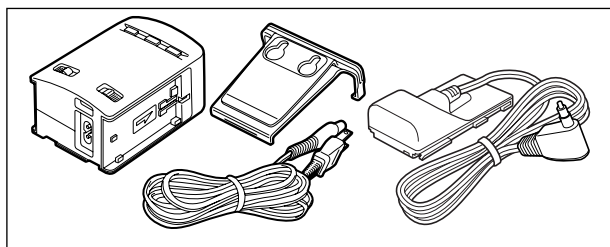



Battery Pack	Charging Time
BP-930	240 min.
BP-945	280 min.

Charging time varies according to the charging condition.

Zoom Remote Controller ZR-1000

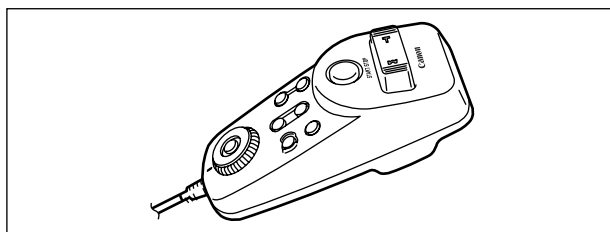
When this product is plugged into the LANC  terminal of a Canon camcorder, it is possible to control functions such as the start and stop of recording and the zoom and focusing functions while the camcorder is mounted on a tripod, without touching the camcorder body itself.



	This mark identifies genuine Canon video accessories. When you use Canon video equipment, we recommend Canon-brand accessories or products bearing the same mark.
---	---

Provided accessories:

CA-920 Compact Power Adapter	8029A002AA
DC-920 DC Coupler	8033A001AA
BP-930 Battery Pack	3058A002AA
SS-1000 Shoulder Strap	D81-1220-000
WL-D4000 Wireless Controller	D83-0690-000
S-150 S-Video Cable	3062A002AA
STV-150 Stereo Video Cable	3065A002AA
Adapter holder	D82-0780-000

Additional accessories supplied with the Lens Kit:

20× L IS Lens	9825A002AA
Lens Hood	D52-0290-000
Lens Soft Case	D81-1490-000

Optional accessories:

BP-945 Battery Pack	4244A002AA
CB-920 Car Battery Adapter	8034A002AA
CH-910 Dual Battery Charger/Holder	3036A002AA
ZR-1000 Zoom Remote Controller	3089A002AA
TA-100 Tripod Adapter	9859A001AA
Extender XL 1.6×	3163A002AA
EF Adapter XL	3162A002AA
3× Zoom Lens XL 3.4-10.2mm	3159A002AA
16× Zoom Lens XL 5.4-86.4mm	7122A002AA
FS-72U Filter Set	3093A002AA
HC-3200 System Case	9826A001AA
DVM-CL DV Cleaning Cassette	3134A002AA
FU-1000 Monochrome Viewfinder	4252A001AA

Specifications

XL2

System

Video Recording System	2 rotary heads, helical scanning DV system (consumer digital VCR SD system), digital component recording
Audio Recording System	PCM digital sound: 16 bit (48 kHz/2 ch); 12 bit (32 kHz/4 ch)
Television System	EIA standard (525 lines, 60 fields) NTSC color signal
Image Sensor	1/3-inch CCD x 3 (horizontal pixel shift), approx. 680,000 pixels Effective pixels: 4:3 approx. 350,000 pixels 16:9 approx. 460,000 pixels
Tape Format	Videocassettes bearing the "MiniDV" mark.
Tape Speed	SP: 0.74 ips (18.81 mm/s), LP: 0.49 ips (12.56 mm/s)
Maximum Recording Time (80 min. cassette)	SP: 80 min., LP: 120 min.
Fast Forward/Rewind Time	Approx. 2 min. 20 sec. (with a 60 min. cassette)
Viewfinder	2-inch. TFT color, approx. 200,000 pixels, RGB delta configuration
Microphone	Stereo electret condenser microphone
Lens mount	XL interchangeable mount system
AF system	TTL autofocus, manual focusing with focus ring (with 20× L IS lens)
White Balance	Auto white balance, pre-set white balance (indoor, outdoor) or custom white balance
Minimum Illumination	0.7 lx (with 20× L IS lens, 60i mode, Manual mode, 1/8 shutter, F1.6, Gain 18 dB)
Recommended Illumination	More than 100 lx

Input/Output Terminals

S-video Terminal	1 Vp-p/75 ohms (Y signal), 0.286 Vp-p/75 ohms (C signal)
Video Terminal	RCA jack/BNC jack 1 Vp-p/75 ohms unbalanced
Audio Out Terminals	RCA jack (L, R) 2 sets -10 dBv (47 kohm load, full-scale -12 dB)/3 kohms or less, unbalanced
Audio In Terminals	FRONT MIC: ø3.5 stereo mini jack (unbalanced), ATT: 20 dB -55 dBv (Auto mode)/600 ohms Max: -67 dBv (Manual mode, max. volume) AUDIO 1, 2: RCA jack (unbalanced) -10 dBv/47 kohms REAR: XLR jack (pin1: shield, pin2: hot, pin3: cold), ATT: 20 dB -54 dBv (Auto mode)/600 ohms Max 1: -66 dBv (Auto mode, REAR MIC Gain Up 12 dB) Max 2: -66 dBv (Manual mode, max. volume) Max 3: -78 dBv (Manual mode, max. volume, REAR MIC Gain Up 12 dB)
DV Terminal	Special 4-pin connector (IEEE1394 compliant)
Headphone Terminal	ø3.5 mm stereo mini-jack -23.5 dBv (16 ohm load)/50 ohms
LANC Terminal	ø2.5 mm stereo mini-jack

Power/Others

Power supply (rated)	7.2 V DC
Power consumption	7.1 W (recording with autofocus, 20× L IS Lens mounted)
Operating temperature	32 – 104 °F (0 – 40 °C)
Dimensions (W × H × D)	8.9 × 8.7 × 19.5 in. (225 × 220 × 496 mm)
Weight (camcorder body only)	5.3 lb. (2410 g)
(fully loaded)	7.8 lb. (3545 g)

Lens

Some lens specifications change as shown below when mounting on the XL2.

	Angle of view		Field size at closest focusing distance	
	Wide angle	Telephoto	Wide angle	Telephoto
20× L IS Lens	37° 12' × 27° 42' (4:3) 48° 24' × 27° 42' (16:9)	1° 54' × 1° 24' (4:3) 2° 36' × 1° 24' (16:9)	[20 mm] 44.1 × 32.0 mm (4:3) 60.0 × 32.0 mm (16:9)	[1 m] 49.1 × 36.0 mm (4:3) 65.6 × 36.0 mm (16:9)
16× IS II Zoom Lens	36° 36' × 27° 12' (4:3) 47° 42' × 27° 12' (16:9)	2° 24' × 1° 42' (4:3) 3° 12' × 1° 42' (16:9)	[20 mm] 41.9 × 30.4 mm (4:3) 57.1 × 30.4 mm (16:9)	[1 m] 55.2 × 40.4 mm (4:3) 73.8 × 40.4 mm (16:9)
3× Zoom XL Lens	56° 18' × 42° 48' (4:3) 71° 6' × 42° 48' (16:9)	20° 12' × 14° 54' (4:3) 26° 48' × 14° 54' (16:9)	[20 mm] 54.6 × 40.0 mm (4:3) 72.8 × 40.0 mm (16:9)	[0.5 m] 188.5 × 138.3 mm (4:3) 251.6 × 138.3 mm (16:9)
16× Manual Zoom Lens	37° 12' × 27° 42' (4:3) 48° 24' × 27° 42' (16:9)	2° 24' × 1° 48' (4:3) 3° 12' × 1° 48' (16:9)	[50 mm] 55.6 × 40.2 mm (4:3) 75.7 × 40.2 mm (16:9)	[1 m] 39.1 × 28.7 mm (4:3) 52.0 × 28.7 mm (16:9)

CA-920 Compact Power Adapter

Power supply	100 – 240 V AC, 50/60 Hz
Power consumption	24 W
Rated output	Adapter: 7.2 V DC, 2.0 A, Charger: 8.4 V DC, 1.5 A
Operating temperature	32°– 104 °F (0°– 40 °C)
Dimensions	3.0 × 3.9 × 2.0 in. (75 × 99 × 51 mm)
Weight	7.6 oz. (215 g) without power cable

BP-930 Battery Pack

Battery type	Rechargeable lithium ion battery
Rated voltage	7.2 V DC
Operating temperature	32°– 104 °F (0°– 40 °C)
Battery capacity	3,000 mAh
Dimensions	1.5 × 1.5 × 2.8 in. (38.2 × 39.0 × 70.5 mm)
Weight	6.7 oz. (190 g)

Weight and dimensions are approximate. Errors and omissions excepted. Subject to change without notice.

Index

16:9 46

A

Abroad, using the
 camcorder 112
Accessories 8, 116
AE shift 62
Analog-digital converter 99
Analog line-in 97
Audio level indicator 53
Audio mode 50
Audio output 89
Audio recording 50
Audio reference signal 78
Auto 55
Autofocus 40
Av mode 55

B

Backup battery 16
Battery pack 13
Black level 68

C

Center marker 34
Character recording 83
Clear scan 73
Color bars 77
Color gain 68
Color matrix 68
Color phase 69
Condensation 110
Coring 69
Custom keys 74
Custom preset 68

D

Data code 93
Date and time 30
Date format 84
Date search 92
DC coupler 14
DV control 82
DV dubbing 98
DV terminal 98, 101

E

Easy recording mode 55
Edit search 86
End search 37
Exposure 61

F

Focus preset 42
Focusing 41
Frame rate 44

G

Gain 63
Gamma 68
Grip belt 21
Grip zoom 38

H

Handle zoom 38
Hue 67

I

Index search 91
Index write 75
Interval timer 79

K

Knee 68

L

Language 84
LCD panel 19
Lens hood 23
Low-angle recording 33
Low light mode 56
LP mode 83

M

Maintenance 108
Manual focus 41
Manual mode 55
Master pedestal 69
Menu 26
Microphone 20, 51
Mix balance 89

N

ND filter 43
NR 69

O

Optional accessories 116

P

Playback 85
Power adapter 13
Power save 33
Programmed AE 55

R

Recording 32
Recording Programs 55
Record review 36
Record search 36
Remote sensor 24

S

Screen display 104-106
Self-timer 81

Setup level 69
Sharpness 69
Shoulder strap 21
Shutter speed 58
Skin detail 67
Spotlight 55
SP Mode 83

T

Tally lamp 83
Tape protection 112
Time code 47
Troubleshooting 113
Tv mode 55
TV screen 87

U

User Bit 49

V

VCR STOP 33, 74
Video heads 110
Viewfinder 17-20

W

Widescreen 46
Wireless controller 24
White balance 64

X

XL lens 22, 116

Z

Zebra pattern 66
Zero set memory 90
Zoom preset 39
Zooming 38

Audio Block Diagram

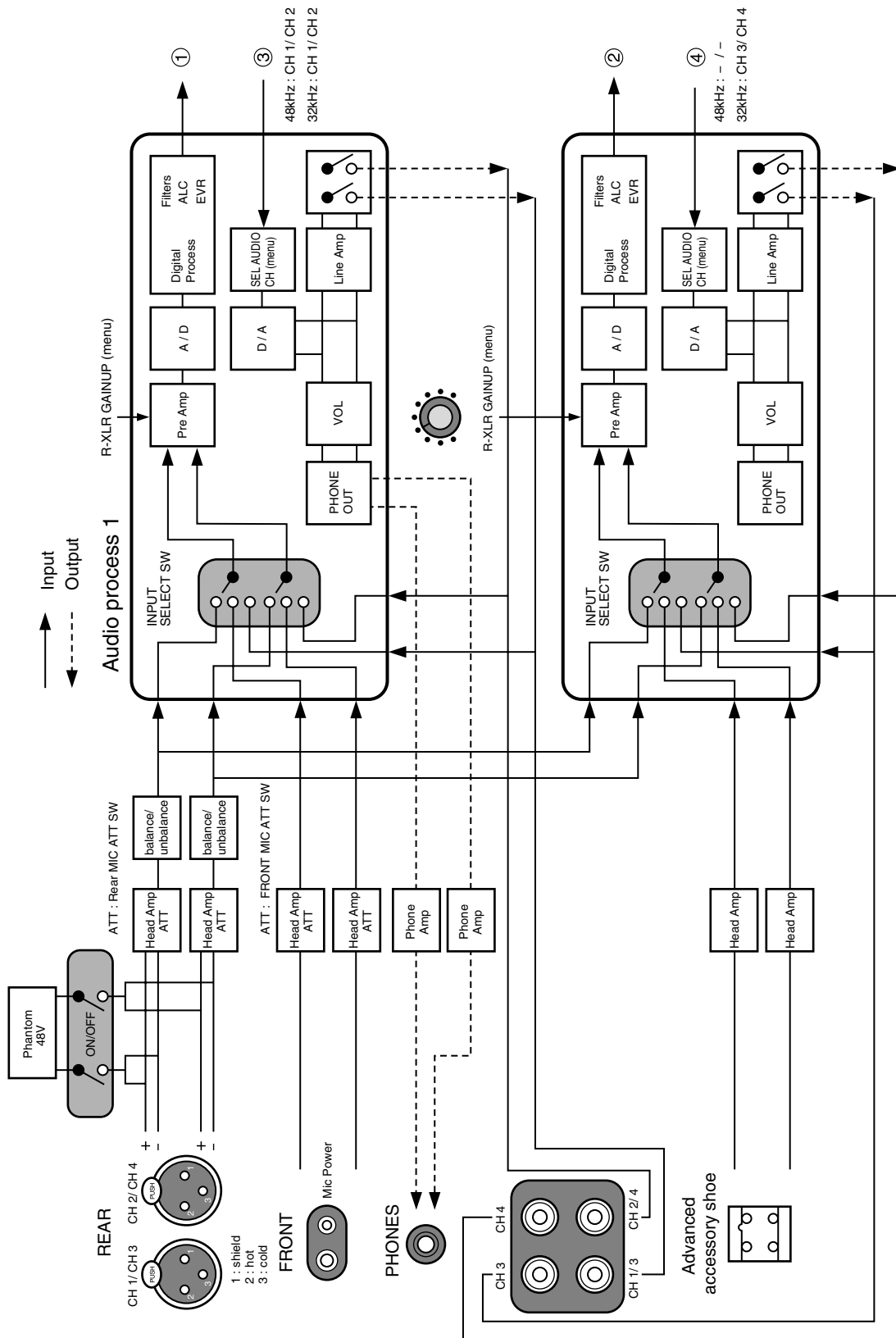

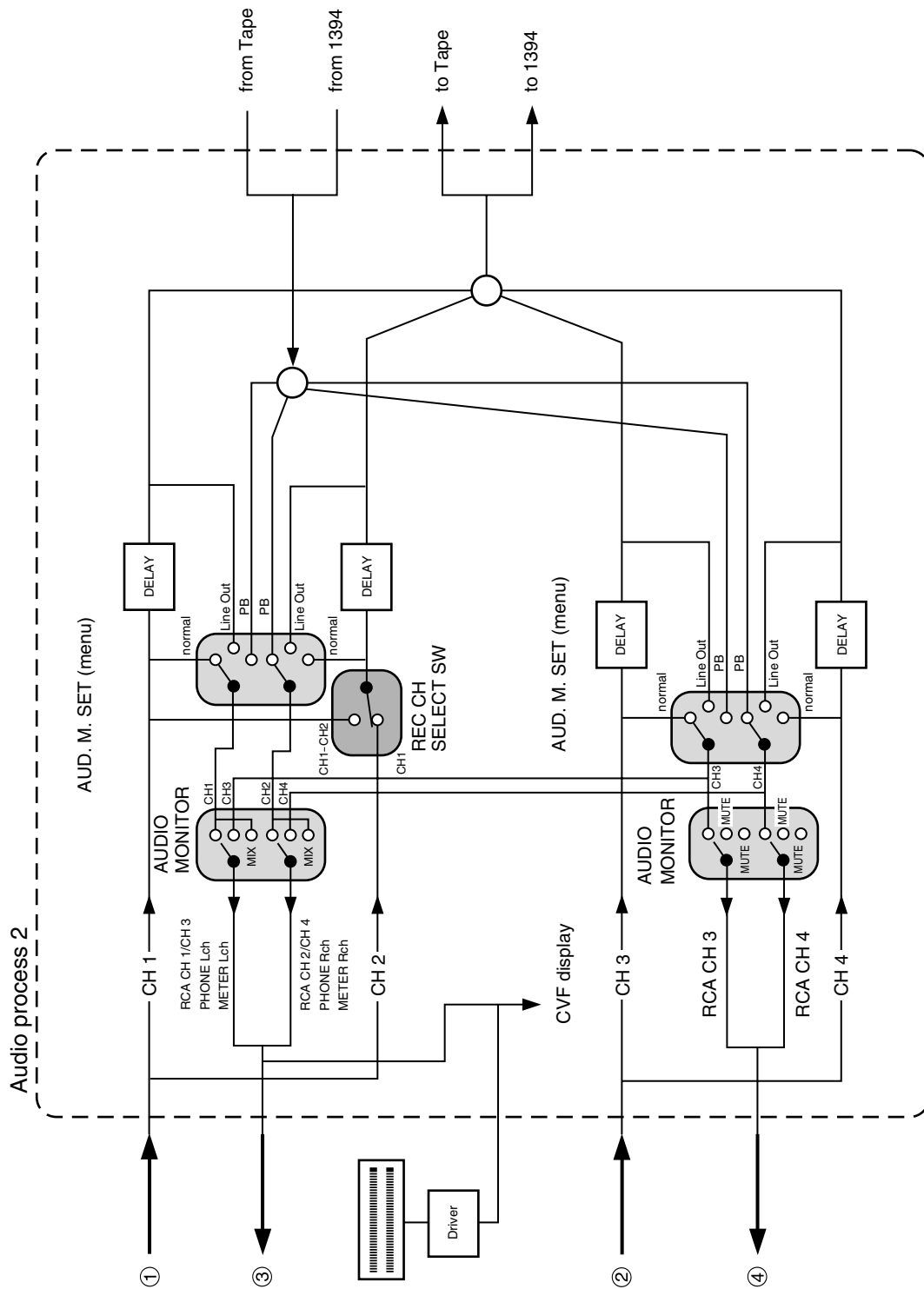

U.S.A.

CANON CONSUMER DIGITAL VIDEO EQUIPMENT LIMITED WARRANTY FOR THE UNITED STATES

The warranty set forward below is given by Canon U.S.A., Inc. with respect to equipment purchased in the United States. The limited warranty is only effective upon presentation of your Bill of Sale or other proof of purchase.

Canon consumer digital video equipment is warranted under normal, non-commercial, personal use, against defective materials or workmanship as follows:

Parts: Defective parts will be exchanged for new parts or comparable rebuilt parts for a period of ONE YEAR from the date of original purchase, except for a defective Video Head, which will be exchanged for a period of three months from the date of purchase.

Labor: For a period of ONE YEAR from the date of original purchase, labor will be provided free of charge by our factory service centers or designated service facilities located in the United States.

When returning equipment under this warranty, you must pre-pay the shipping charges, and you must enclose the Bill of Sale or other proof of purchase with a complete explanation of the problem. During your ONE-YEAR warranty period, repairs will be made and the equipment return-shipped to you free of charge. After your warranty period is over, you will be given an estimate of the cost of repair and an opportunity to approve or disapprove of the repair expense before it is incurred. If you approve, repairs will be made and the equipment return-shipped to you. (shipping charges apply). If you disapprove, we will return-ship the equipment at no charge to you.

Non-Canon brand peripheral equipment and software which may be distributed with Canon DV camcorders are sold "AS IS" without warranty of any kind by CUSA, including any implied warranty regarding merchantability or fitness for a particular purpose. The sole warranty with respect to such non-Canon brand items is given by the manufacturer or producer thereof.

CUSA shall have no responsibility under this limited warranty for use of Canon DV Camcorders in conjunction with incompatible peripheral equipment and incompatible software.

In order to obtain warranty service, contact the authorized Canon retail dealer from whom you purchased the DV Camcorder or call the CANON INFORMATION CENTER AT 1-800-828-4040. You will be directed to the nearest service facility for your product.

This Limited Warranty covers all defects encountered in normal use of the equipment and does not apply in the following cases:

- A) Loss or damage to the equipment due to abuse, mishandling, accident, improper maintenance, or failure to follow operating instructions;
- B) If the equipment is defective as a result of leaking batteries, sand, dirt or water damage;
- C) If defects or damages are caused by the use of unauthorized parts or by service other than our authorized agent;
- D) If the equipment is used for commercial or industrial use.

This Limited Warranty does not cover cabinet (exterior finish), video cassette tape, head cleanings, nor does it apply to equipment purchased outside the United States. This warranty does not cover units sold to rental firms, military operations, hotels, schools, hospitals or for other commercial, industrial, or institutional applications. These uses are covered only by such specific warranty as Canon may issue with such sales.

This Limited Warranty does not apply to accessories or consumables for the DV Camcorder, which are sold "AS IS", without warranty of any kind by CUSA.

Please retain this warranty card and your Bill of Sale as a permanent record of your purchase. This card is most important in order to be sure you are contacted right away should there be a safety inspection, modification or product recall under applicable laws or regulations.

NO IMPLIED WARRANTY, INCLUDING MERCHANTABILITY AND FITNESS FOR A PARTICULAR PURPOSE APPLIES TO THIS EQUIPMENT AFTER THE APPLICABLE PERIOD OF EXPRESS WARRANTY OR GUARANTY, EXCEPT AS MENTIONED ABOVE, GIVEN BY ANY PERSON, FIRM OR CORPORATION WITH RESPECT TO THIS EQUIPMENT SHALL BIND THE UNDERSIGNED. (SOME STATES DO NOT ALLOW LIMITATIONS ON HOW LONG AN IMPLIED WARRANTY LASTS, SO THE ABOVE LIMITATION OR EXCLUSION MAY NOT APPLY TO YOU). CUSA SHALL NOT BE LIABLE FOR LOSS OF REVENUES OR PROFITS, EXPENSE FOR SUBSTITUTE EQUIPMENT OR SERVICE, STORAGE CHARGES, LOSS OF DATA, OR ANY OTHER SPECIAL, INCIDENTAL OR CONSEQUENTIAL DAMAGES CAUSED BY THE USE, MISUSE OR INABILITY TO USE THE DV CAMCORDER, REGARDLESS OF THE LEGAL THEORY ON WHICH THE CLAIM IS BASED, AND EVEN IF CUSA HAS BEEN ADVISED OF THE POSSIBILITY OF SUCH DAMAGES. NOR SHALL RECOVERY OF ANY KIND AGAINST CUSA BE GREATER THAN THE PURCHASE PRICE OF THE DV CAMCORDER SOLD BY CUSA AND CAUSING THE ALLEGED DAMAGE. WITHOUT LIMITING THE FOREGOING, YOU ASSUME ALL RISK AND LIABILITY FOR LOSS, DAMAGE OR INJURY TO YOU AND YOUR PROPERTY AND TO OTHERS AND THEIR PROPERTY ARISING OUT OF USE, MISUSE OR INABILITY TO USE THE DV CAMCORDER NOT CAUSED DIRECTLY BY THE NEGLIGENCE OF CUSA. (SOME STATES DO NOT ALLOW THE EXCLUSION OR LIMITATION OF INCIDENTAL OR CONSEQUENTIAL DAMAGES, SO THE ABOVE LIMITATION MAY NOT APPLY TO YOU). THIS WARRANTY SHALL NOT EXTEND TO ANYONE OTHER THAN THE ORIGINAL PURCHASER OF THIS EQUIPMENT OR THE PERSON FOR WHOM IT WAS PURCHASED AS A GIFT.

This warranty gives you specific legal rights, and you may also have other rights which vary from state to state.

CANON U.S.A., INC.

CANADA

CANON CONSUMER DIGITAL VIDEO EQUIPMENT LIMITED WARRANTY

The limited warranty set forth below is given by Canon Canada Inc. ("Canon Canada") with respect to Canon digital video equipment purchased in Canada. This limited warranty is only effective upon presentation of a bill of sale or other proof of purchase for this Canon digital video equipment to a Canon Service Facility when repairs are required.

Canon consumer video digital equipment is warranted under normal, non-commercial, personal use, against defective materials or workmanship as follows:

Parts: Defective parts will be exchanged for new parts or, at Canon Canada's option, comparable rebuilt parts for a period of one year from the date of original purchase, except Video Heads which will be exchanged for a period of 3 months from the date of purchase.

Labour: For a period of one year from the date of original purchase, labour will be provided free of charge by our Canon Service Facilities in Canada.

This limited warranty covers all defects except where:

- (a) The loss or damage to the product results from:
 - i) accident, natural disaster, mishandling, abuse, neglect, unauthorized product modification or failure to follow instructions contained in the instruction manual;
 - ii) the use of accessories, attachments, products, supplies, parts or devices with this Canon product that do not conform to Canon specifications or that cause abnormally frequent service problems;
 - iii) repairs or services performed by any party other than a Canon Service Facility;
 - iv) defective batteries or any exposure to water, sand or dirt;
 - v) shipping (claim must be presented to the shipper);
- (b) Any serial number on the video equipment is altered or removed.
- (c) The digital video equipment is used for commercial, professional or industrial purposes.

This limited warranty does not cover the cabinet (exterior finish) of the digital video equipment, video cassette tapes, head cleanings, nor does it apply to digital video equipment purchased outside Canada.

TO OBTAIN WARRANTY SERVICE

Ship your Canon digital video equipment in its original carton, box or equivalent, properly packed, fully insured with shipping charges prepaid, together with a copy of your bill of sale or other proof of purchase and a description of the problem to any of the Canon Service Facilities in Canada.

LIMITATIONS

Except as otherwise required by applicable legislation, this warranty is in lieu of all other warranties, conditions, guarantees or representations, express or implied, statutory or otherwise, relative to this Canon product, including implied warranties or conditions of merchantability or fitness for a particular purpose.

Canon Canada assumes no liability for special, consequential or incidental damages or loss that may arise, whether on account of negligence or otherwise, from the use, misuse or inability to use this Canon product (including loss of profit, revenue, video tapes or enjoyment) or from failure to conform to any express or implied warranties, conditions, guarantees or representations. Any recovery under this limited warranty shall not exceed the purchase price of the product. Canon Canada does not assume or authorize any other person to assume for Canon Canada any other liability with respect to this Canon product. This warranty does not extend to any person other than the original purchaser of this Canon product or the person for whom it was purchased as a gift and states your exclusive remedy.

NOTICE TO CONSUMER

If you plan to take important videos or if the product has not been used for some time, please check all functions with the instruction book before using it.



CANON INC.

U.S.A. ————— **CANON U.S.A., INC. NEW JERSEY OFFICE**
100 Jamesburg Road, Jamesburg, NJ 08831 USA
CANON U.S.A., INC. CHICAGO OFFICE
100 Park Blvd., Itasca, IL 60143 USA
CANON U.S.A., INC. LOS ANGELES OFFICE
15955 Alton Parkway, Irvine, CA 92618 USA
CANON U.S.A., INC. HONOLULU OFFICE
210 Ward Avenue, Suite 200, Honolulu, HI 96814 USA

- If you have any questions, call the Canon U.S.A. Information Center toll-free at 1-800-828-4040 (U.S.A. only).

CANADA ————— **CANON CANADA INC. NATIONAL HEADQUARTERS**
6390 Dixie Road, Mississauga, Ontario L5T 1P7
CANON CANADA INC. CALGARY
2828, 16th Street, N.E. Calgary, Alberta T2E 7K7
CANON CANADA INC. MONTREAL
5990 Côte de Liesse, Quebec H4T 1V7

- If you have any questions, call the Canon Canada Information Center toll-free at 1-800-828-4040. (Canada only)
- Si vous avez des questions, veuillez téléphoner sans frais au Canada 1-800-828-4040. (Canada seulement)

MEXICO ————— **CANON MEXICANA, S. DE R.L. DE C.V.**
Periferico Sur No. 4124 Col. Ex-Rancho de Anzaldo C.P. 01900
México, D.F., México

CENTRAL Y SURAMÉRICA — **CANON LATIN AMERICA, INC.**
703 Waterford Way Suite 400 Miami, FL 33126 USA

ASIA ————— **CANON HONGKONG COMPANY LTD.**
19/F, The Metropolis Tower, 10 Metropolis Drive, Hunghom, Kowloon, Hong Kong



Printed on 100% reused paper.
Document réalisé avec du papier recyclé à 100%.
El papel aqui utilizado es 100% reciclado.